

# GLP-1s

There's a ton with GLP-1

Nicole Likar, PharmD, BCPS

Sarah Winter, PharmD, BCACP

---



# Disclosure

---

No Disclosures

# Objectives

---

- Outline the indications for GLP-1/GIP agents
- Review dosing, side effects, contraindications
- Discuss the data and outcomes for obesity and diabetes
- Apply information to patient case

# GLP-1 Mechanism

## Glucagon-like Peptide-1 Receptor Agonism

## Glucose-dependent Insulinotropic Polypeptide Receptor Agonism

### Central Nervous System

- ↑ Satiety
- ↓ Food Intake
- ↑ Nausea
- ↓ Body Weight

### Pancreas

- ↑ Insulin
- ↓ Glucagon

### Stomach

- ↓ Gastric Emptying

### Systemic

- ↓ Hyperglycemia

### Liver

- ↑ Insulin Sensitivity
- ↓ Hepatic Glucose Production
- ↓ Ectopic Lipid Accumulation

- Glucose-dependent Insulinotropic Polypeptide Receptor Agonism
- Glucagon-like Peptide 1 Receptor Agonism
- Indirect Action

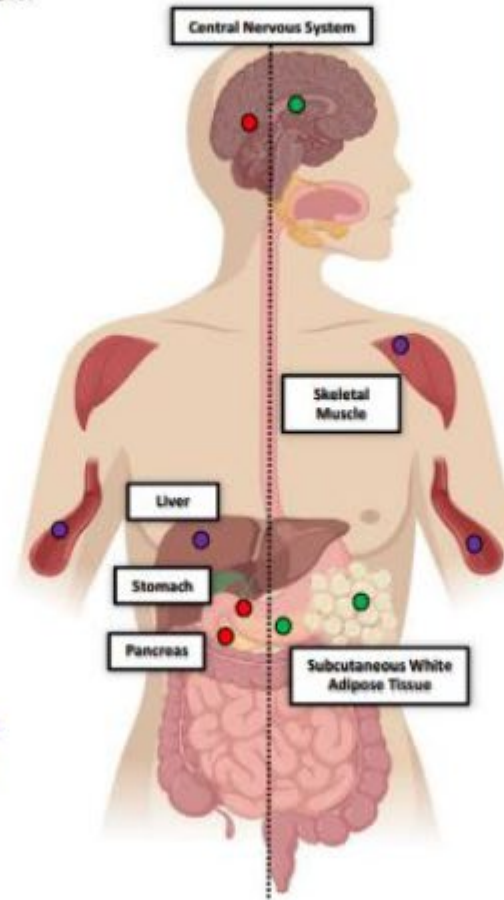

### Central Nervous System

- ↓ Food Intake
- ↓ Nausea
- ↓ Body Weight

### Pancreas

- ↑ Insulin
- ↑ Glucagon

### Subcutaneous White Adipose Tissue

- ↑ Insulin Sensitivity
- ↑ Lipid Buffering Capacity
- ↑ Blood Flow
- ↑ Storage Capacity
- ↓ Proinflammatory Immune Cell Infiltration

### Systemic

- ↓ Hyperglycemia
- ↓ Dietary Triglyceride

### Skeletal Muscle

- ↑ Insulin Sensitivity
- ↑ Metabolic Flexibility
- ↓ Ectopic Lipid Accumulation

# GLP-1/GIP Agents

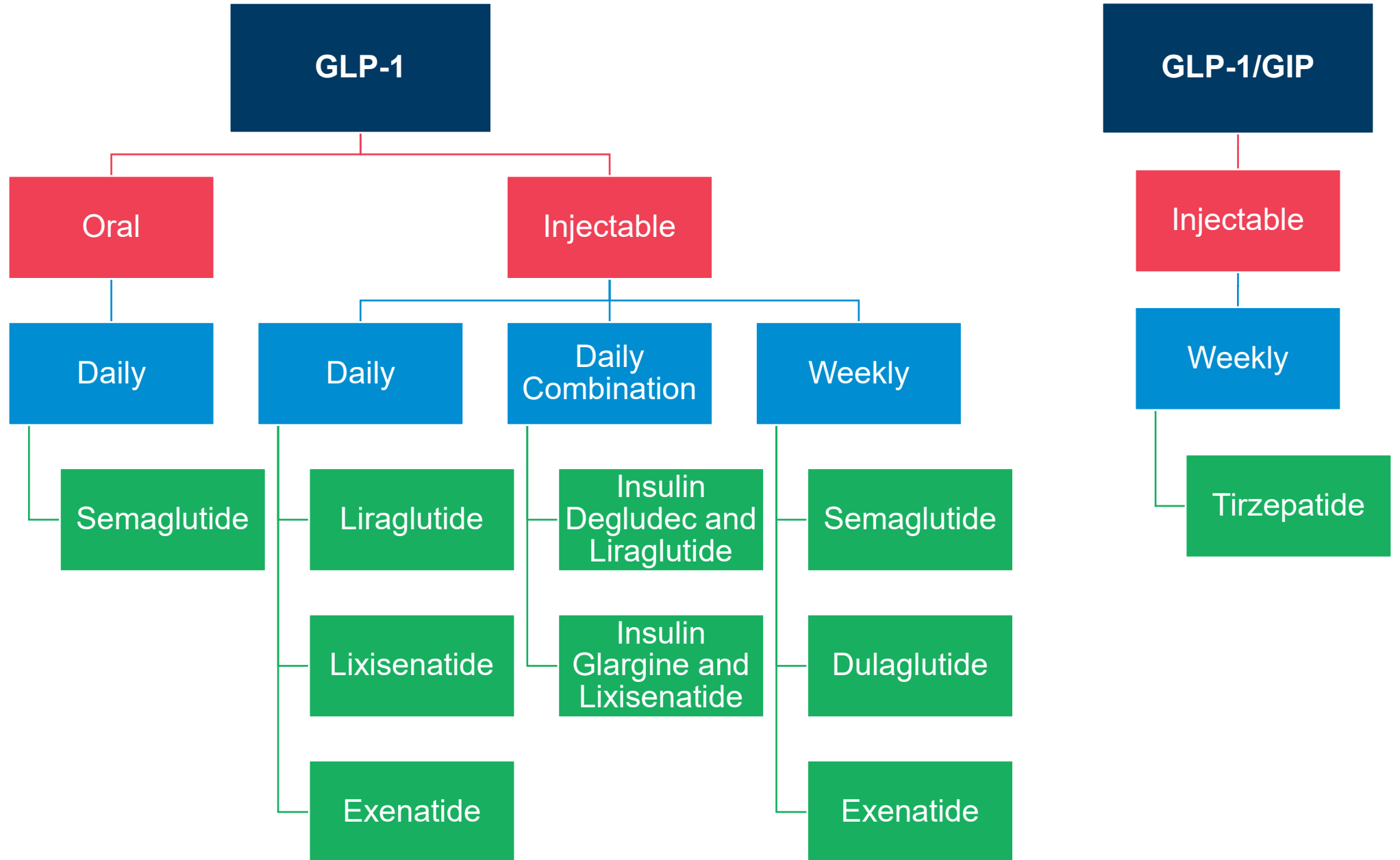

# GLP-1/GIP Medications and Indications

Medication	Diabetes	Obesity	Cardiovascular Risk Reduction	OSA
Liraglutide	Victoza	Saxenda	--	--
Semaglutide	Ozempic (SC)	Wegovy	Wegovy	--
	Rybelsus (oral)	--	--	--
Dulaglutide	Trulicity	--	--	--
Tirzepatide	Mounjaro	Zepbound	--	Zepbound

# GLP-1/GIP Dosing Per Indication

Medication	Diabetes	Obesity	Cardiovascular Risk Reduction
Liraglutide	<p><b>Victoza</b> Initial dose 0.6mg daily, titrate weekly by 0.6mg*, max dose 1.8mg daily</p>	<p><b>Saxenda</b> Initial dose 0.6mg daily, titrate weekly by 0.6mg*, max dose 3mg daily</p>	--
Semaglutide	<p><b>Ozempic (SC)</b> Initial dose 0.25mg daily, titrate monthly 0.25mg*, 0.5mg, 1mg, 2mg (max)</p> <p><b>Rybelsus (oral)</b> Initial 3mg daily, titrate monthly – 3mg*, 7mg, 14mg (max)</p>	<p><b>Wegovy</b> Initial dose 0.25mg daily, titrate monthly 0.25mg*, 0.5mg, 1mg, 1.7mg 2.4mg (max)</p>	
* Doses not intended to be maintenance doses			

# GLP-1/GIP Dosing Per Indication

Medication	Diabetes	Obesity	OSA
Dulaglutide	<p><b>Trulicity</b> Initial 0.75mg weekly, titrate monthly, 0.75mg, 1.5mg, 3mg, 4.5mg</p>	--	--
Tirzepatide	<p><b>Mounjaro and Zepbound</b> Initial 2.5mg weekly, titrate monthly, 2.5mg, 5mg, 7.5mg, 10mg, 12.5mg, 15mg</p> <ul style="list-style-type: none"> <li>• 2.5mg dose not intended to be maintenance for diabetes and obesity</li> <li>• Doses &lt;10mg not intended to be maintenance for OSA</li> </ul>		



# GLP-1/GIP Agent Considerations

---

## Contraindications:

- Personal or family history of medullary thyroid carcinoma or in patients with Multiple Endocrine Neoplasia syndrome type 2
- Serious hypersensitivity reaction to the medication or any excipients

## Warnings:

- Pancreatitis
- Diabetic Retinopathy complications
- Concomitant use with an insulin secretagogue or insulin may increase the risk of hypoglycemia
- Acute Kidney Injury
- Acute Gallbladder disease
- Drug Absorption– oral contraception (tirzepatide)

## Side Effects:

- Nausea, vomiting, diarrhea, abdominal pain and constipation



# GLP-1/GIP Agents – Clinical Pearls

## Obesity

- Titrate to efficacy and tolerance

- Low doses still effective
- Hold with anesthesia
- Consider missed dose windows

## Diabetes

- ↓ insulin by ~20% or sulfonylurea by ~50%

---

# Obesity Data

---

# Guidelines – American Association of Clinical Endocrinology 2016



## AACE/ACE ALGORITHM FOR THE MEDICAL CARE OF PATIENTS WITH OBESITY



<b>Patient Presentation</b>	Screen positive for overweight or obesity BMI $\geq 25$ kg/m <sup>2</sup> ( $\geq 23$ kg/m <sup>2</sup> in some ethnicities)	Presence of weight-related disease or complication that could be improved by weight-loss therapy
-----------------------------	---	--

<b>Diagnosis</b>	<b>Evaluation</b>	<ul style="list-style-type: none"> <li>• Medical history    • Physical examination    • Clinical laboratory</li> <li>• Review of systems, emphasizing weight-related complications</li> <li>• Obesity history: graph weight vs age, lifestyle patterns/preferences, previous interventions</li> </ul>					
	<b>Anthropometric Diagnosis</b>	<ul style="list-style-type: none"> <li>• Confirm that elevated BMI represents excess adiposity</li> <li>• Measure waist circumference to evaluate cardiometabolic disease risk</li> </ul>					
	<b>Clinical Diagnosis</b>	<p>&lt;25 NORMAL WEIGHT</p> <p>&lt;23 in certain ethnicities</p> <p>Waist circumference below regional/ethnic cutoffs</p>	<p><b>BMI kg/m<sup>2</sup></b></p> <p>25–29.9 OVERWEIGHT   <math>\geq 30</math> OBESITY</p> <p><b>Checklist of Obesity-Related Complications</b> (staging and risk stratification based on complication-specific criteria)</p> <table border="1" style="width: 100%; text-align: center;"> <tr> <td style="background-color: #F79646; color: white;">None</td> <td style="background-color: #E67E22; color: white;">Mild to Moderate</td> <td style="background-color: #C0392B; color: white;">Severe</td> </tr> </table>			None	Mild to Moderate
None	Mild to Moderate	Severe					

# Guidelines – AACE 2016

Diagnostic Categories	NORMAL WEIGHT (no obesity)	STAGE 0	STAGE 1	STAGE 2
		No complications	One or more mild-to-moderate complications or may be treated effectively with moderate weight loss	At least one severe complication or requires significant weight loss for effective treatment
		OVERWEIGHT BMI 25–29.9 OBESITY BMI ≥30	BMI ≥25	BMI ≥25

  

Phases of Chronic Disease Prevention and Treatment Goals	PRIMARY	SECONDARY	TERTIARY
	Prevent overweight/obesity	Prevent progressive weight gain or achieve weight loss to prevent complications	Achieve weight loss sufficient to ameliorate the complications and prevent further deterioration

Treatment Based on Clinical Judgment	<ul style="list-style-type: none"> <li>• Healthy meal plan</li> <li>• Physical activity</li> <li>• Health education</li> <li>• Built environment</li> </ul>	SECONDARY	STAGE 1	STAGE 2
		<ul style="list-style-type: none"> <li>• Lifestyle/behavioral therapy</li> <li>• Consider pharmacotherapy if lifestyle alone not effective</li> </ul>	<ul style="list-style-type: none"> <li>• Lifestyle/behavioral therapy</li> <li>• Consider pharmacotherapy (BMI ≥27)</li> </ul>	<ul style="list-style-type: none"> <li>• Lifestyle/behavioral therapy</li> <li>• Add pharmacotherapy (BMI ≥27)</li> <li>• Consider bariatric surgery (BMI ≥35)</li> </ul>

# Guidelines – AACE 2016

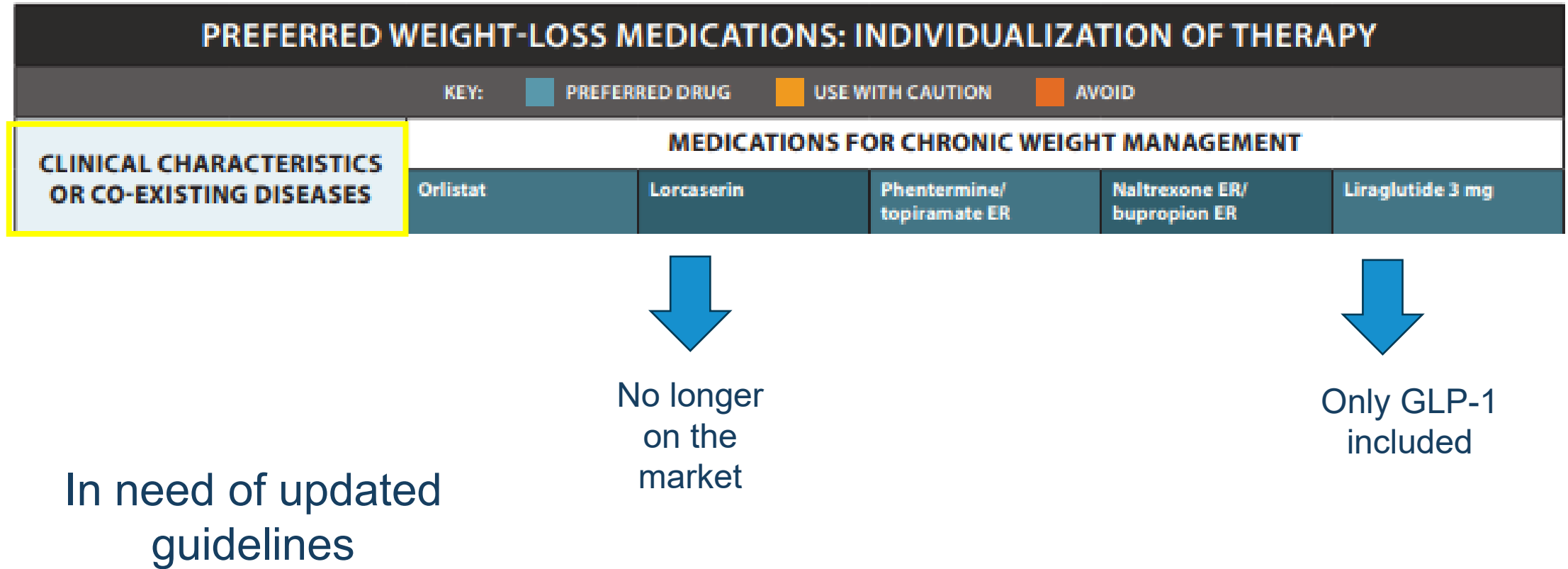

# Guidelines – AACE 2016

---

GLP-1  
preferred

- Diabetes
- Prediabetes
- Metabolic Syndrome
- Hypertension
- Chronic Kidney Disease
- Nephrolithiasis
- Depression
- Anxiety
- Seizure
- Opioid use
- Women of Reproductive Potential
- Age  $\geq 65$
- Alcoholism
- Post-bariatric surgery

GLP-1 not  
preferred

- Pancreatitis
- CHF \*
- Severe Hepatic impairment \*
- Breastfeeding \*



\* No preferred agent for the treatment of obesity

# Guidelines – American Gastroenterological Association 2022

## Pharmacological Interventions for Adults With Obesity

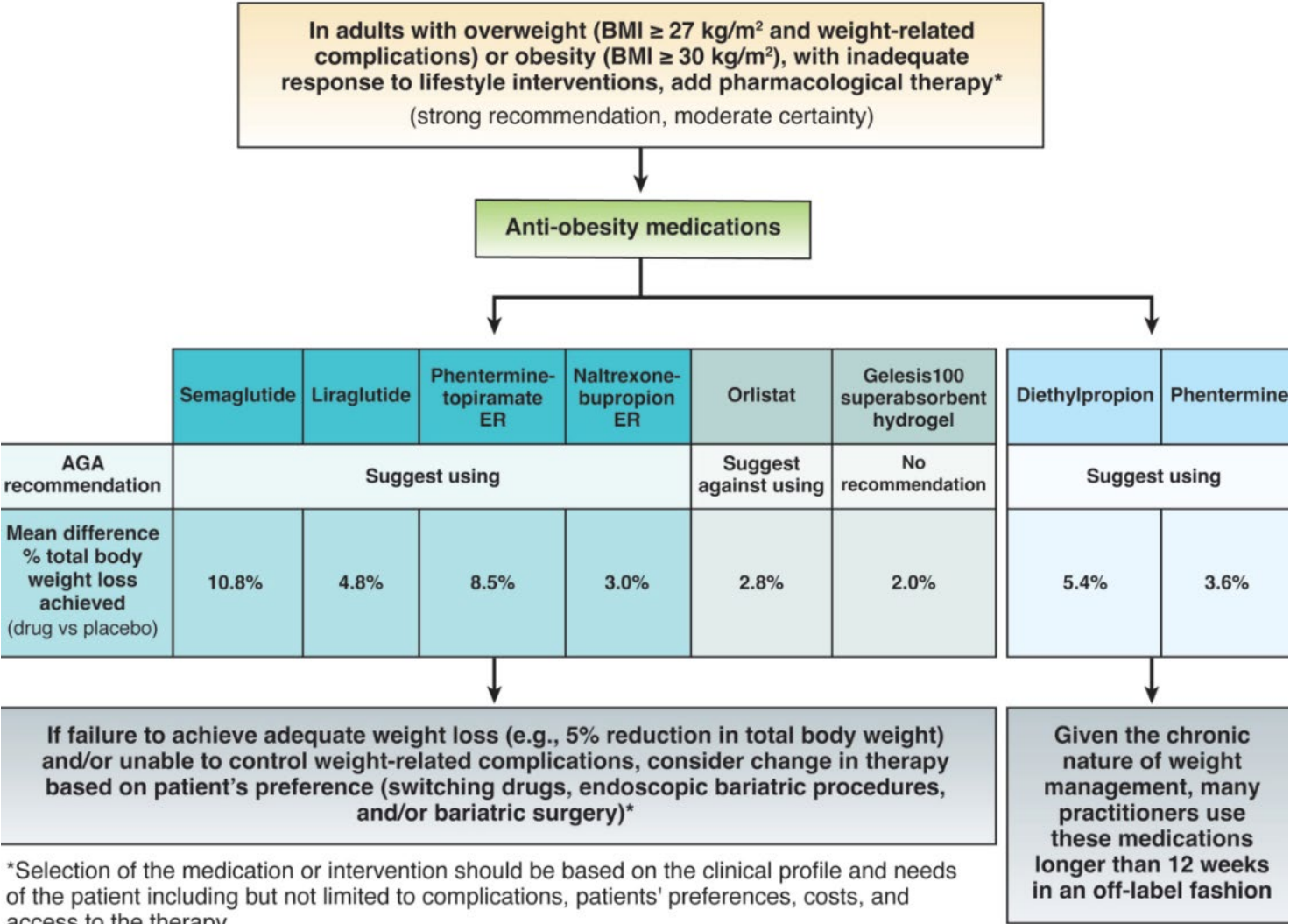

“Given the magnitude of net benefit, semaglutide 2.4mg may be prioritized over other approved anti-obesity medications”

\*Selection of the medication or intervention should be based on the clinical profile and needs of the patient including but not limited to complications, patients' preferences, costs, and access to the therapy



# Weight Loss Summary

Drug	Pertinent Trials	Evidence
Liraglutide (Saxenda®)	SCALE Trials	<ul style="list-style-type: none"> <li>• <b>8%</b> difference in mean weight loss of 3mg compared to placebo</li> <li>• <math>\geq 5\%</math> of baseline body weight lost was <u>44 to 62%</u> at 56 weeks.</li> </ul>
Semaglutide (Wegovy®)	STEP Trials	<ul style="list-style-type: none"> <li>• <b>14.85%</b> difference in mean weight of 2.4mg compared to placebo</li> <li>• <math>\geq 5\%</math> of baseline body weight lost was <u>67 to 85%</u> at 52 weeks.</li> </ul>
Tirzepatide (Zepbound®)	SURMOUNT Trials	<ul style="list-style-type: none"> <li>• <b>20.9%</b> difference in mean weight of 15mg compared to placebo</li> <li>• <math>\geq 5\%</math> of baseline body weight lost was <u>85 to 91%</u> at 72 weeks.</li> </ul>

# Weight Loss Summary

## Liraglutide

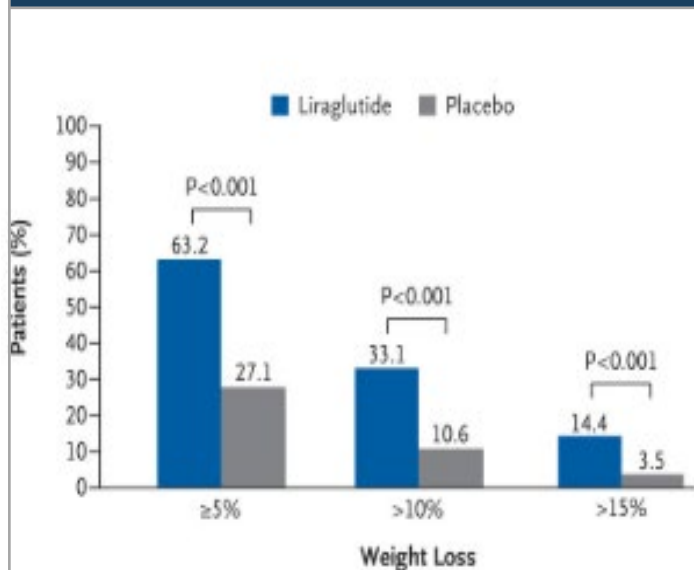

## Semaglutide

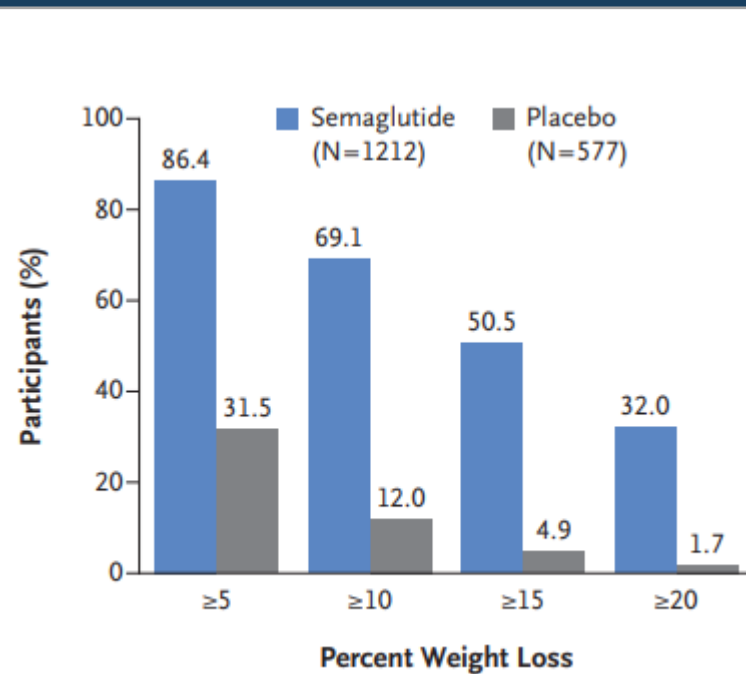

## Tirzepatide

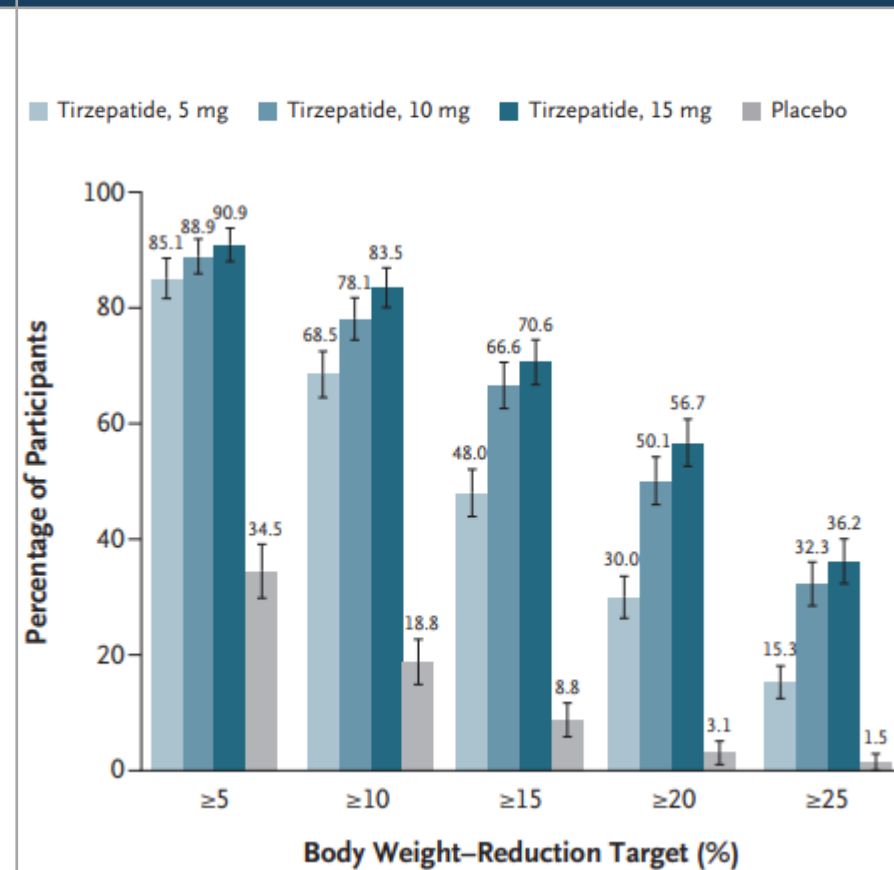

# Head to Head - Semaglutide vs Tirzepatide

Figure 2. Event Probabilities for 5% or Greater, 10% or Greater, and 15% or Greater Weight Reduction Among Propensity-Score Matched Patients on Treatment

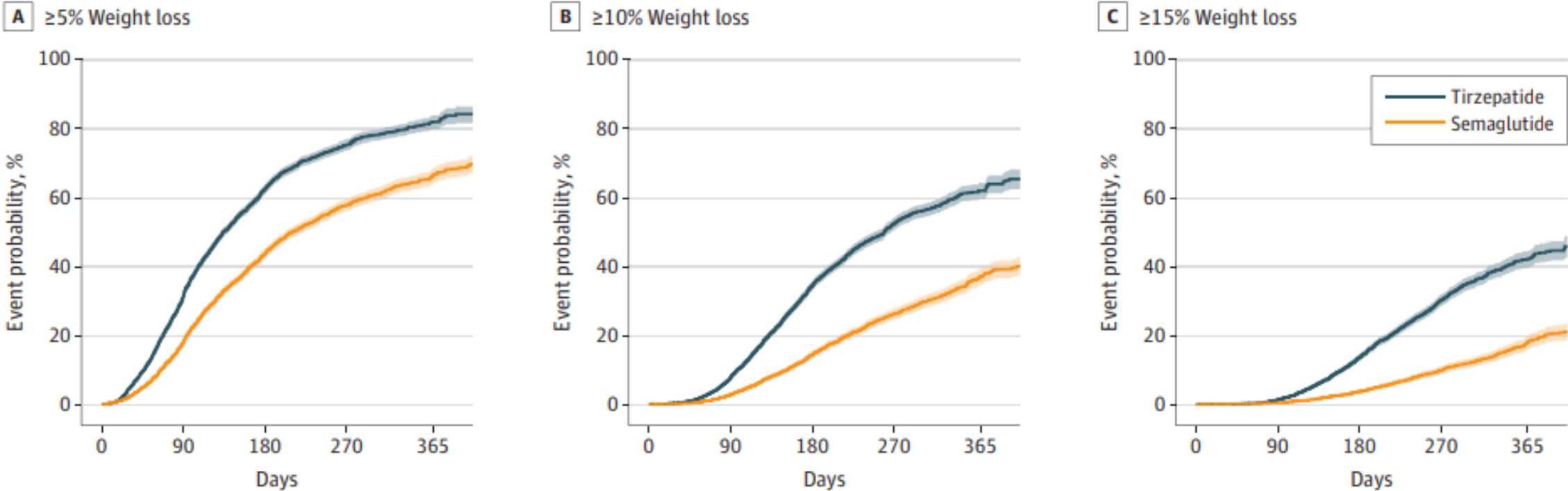

# Weight Changes with Discontinuation

---

Drug	Pertinent Trials	Evidence
Semaglutide (Wegovy®)	STEP-1 Extension N=327	<ul style="list-style-type: none"><li>• Semaglutide and placebo participants regained 11.6% of lost weight, respectively, by week 120</li><li>• Net losses of 5.6% from week 0 to week 120</li><li>• Cardiometabolic improvements seen from week 0 to week 68 with semaglutide reverted towards baseline at week 120 for most variables</li></ul>

# Weight Changes with Discontinuation

## Step 1 Trial Extension with Semaglutide

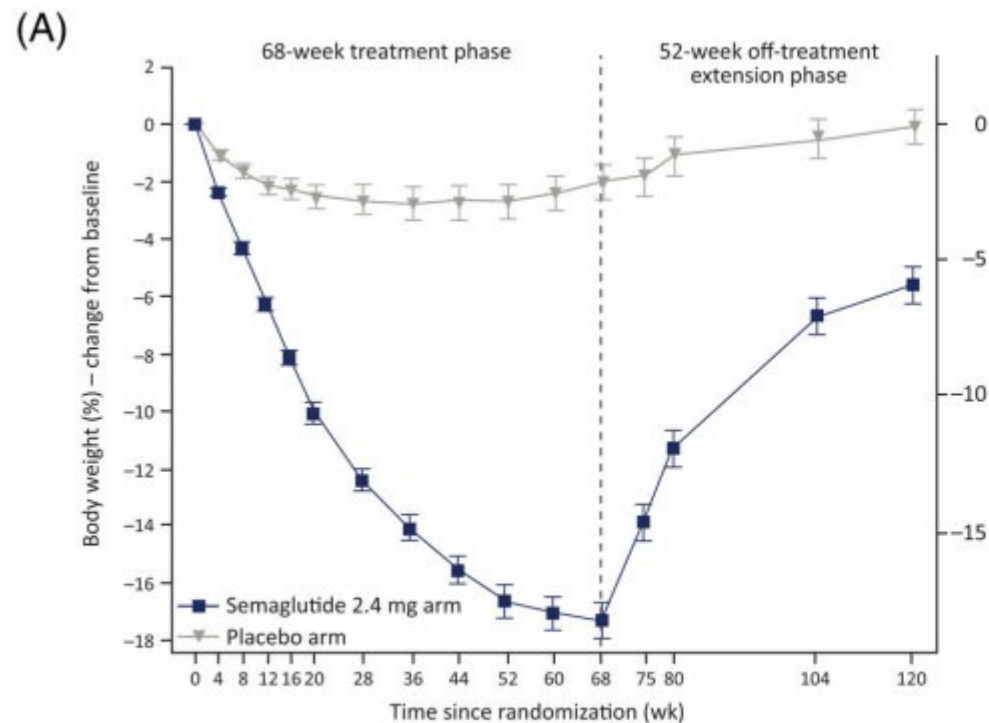

Semaglutide 2.4 mg arm	228	226	228	228	225	228	228	228	228	227	228	209	174	171	197
Placebo arm	99	99	99	98	97	98	99	99	99	99	99	93	79	80	93

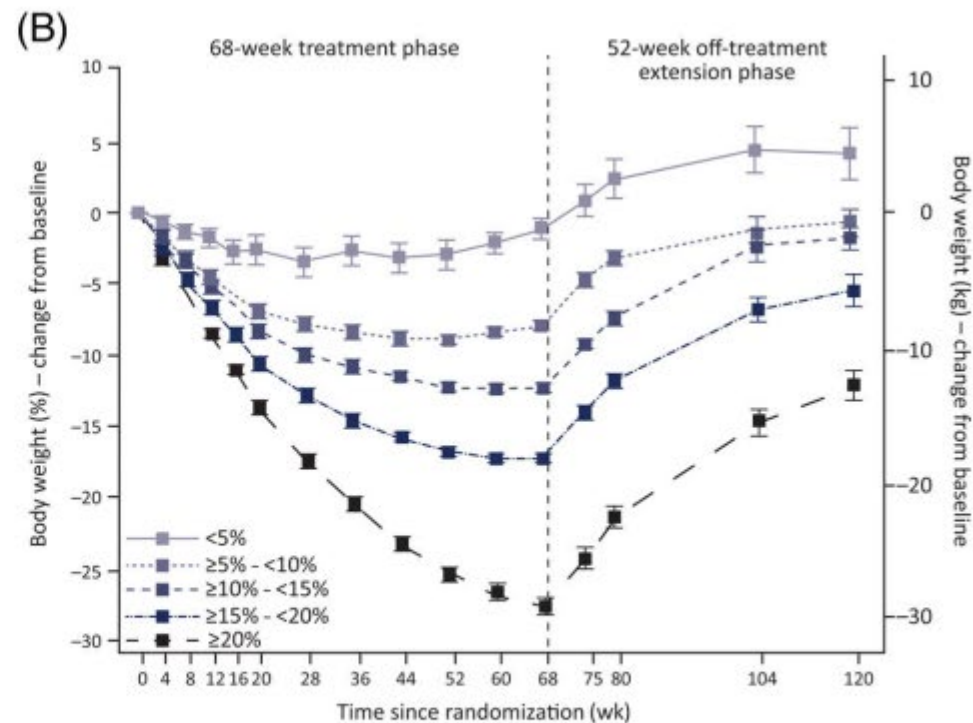

<5%	14	13	14	14	13	14	14	14	14	14	14	14	13	12	11	12
≥5% - <10%	41	40	41	41	40	41	41	41	41	41	41	41	36	32	32	35
≥10% - <15%	45	45	45	45	45	45	45	45	45	45	45	45	44	37	32	37
≥15% - <20%	48	48	48	48	48	48	48	48	48	48	48	48	47	38	41	45
≥20%	80	80	80	80	79	80	80	80	80	80	79	80	69	55	55	68

Findings suggest ongoing treatment is required to maintain improvements in weight and health



# Weight Changes with Discontinuation

---

Drug	Trial N=670	Evidence
Tirzepatide (Zepbound <sup>®</sup> )	<ul style="list-style-type: none"><li>• Open-label lead-in period received tirzepatide for 36 weeks</li><li>• Participants were randomized (1:1) to continue tirzepatide or switch to placebo for 52 weeks.</li></ul>	<ul style="list-style-type: none"><li>• The mean percent weight change from week 36 to week 88 was -5.5% with tirzepatide vs 14.0% with placebo</li><li>• The overall mean weight reduction from week 0 to 88 was 25.3% for tirzepatide and 9.9% for placebo</li></ul>

# Weight Changes with Discontinuation

Figure 2. Effect of Tirzepatide vs Placebo on Body Weight and Waist Circumference

**A** Percent change in body weight (week 0-88)

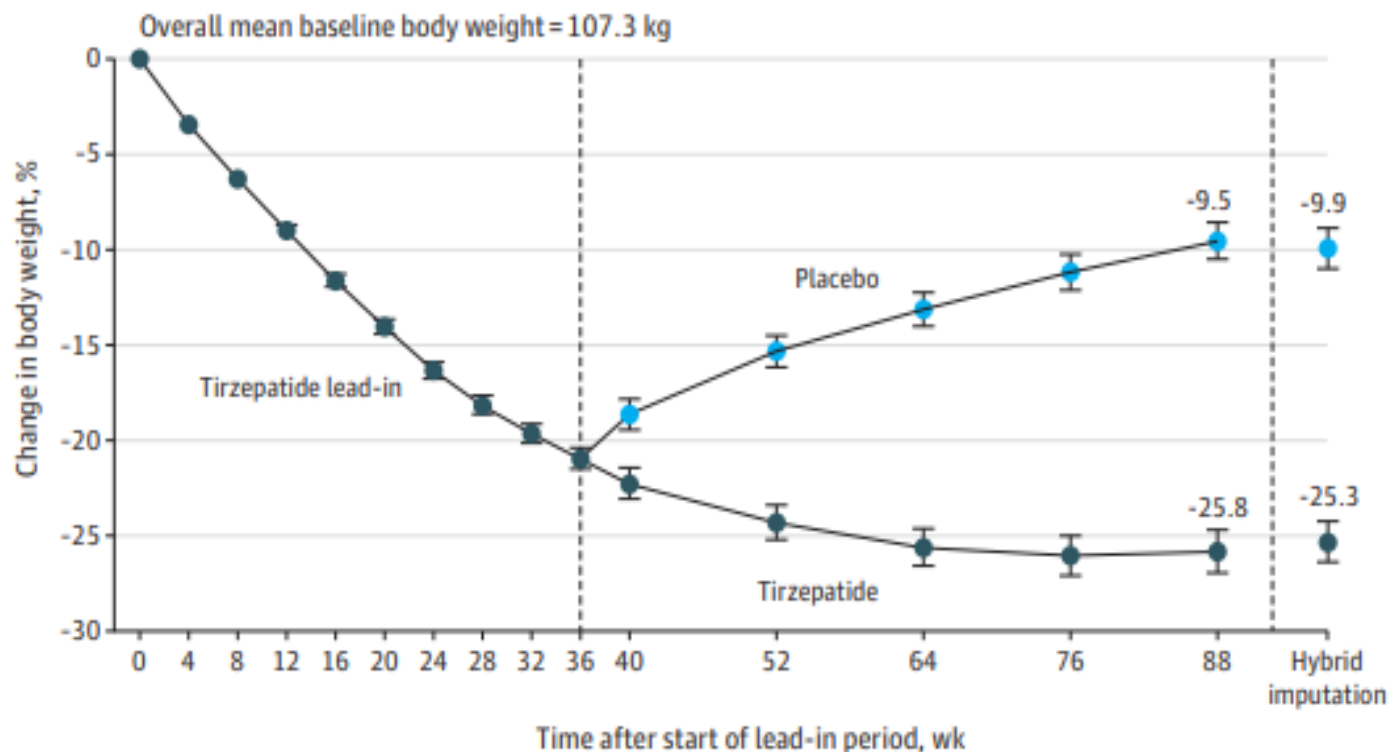

No. at risk

Tirzepatide lead-in 670 666 669 668 667 667 669 663 659 670

Tirzepatide

335 333

328

317

310

310

335

Placebo

335 330

317

303

292

289

335

# Back to the Guidelines – Duration of Therapy

AACE

- Available data support the need for **long-term** use of weight-loss medications in appropriate patients
- High quality clinical trials from 1-4 years
- Optimal duration of therapy is unknown

AGA

- In adults with overweight and obesity who have an inadequate response to lifestyle interventions along, **long-term** pharmacological therapy is recommended, with multiple effective and safe treatment options



# Coverage Confusion

---

Reasons for denials can differ between patients and insurance companies

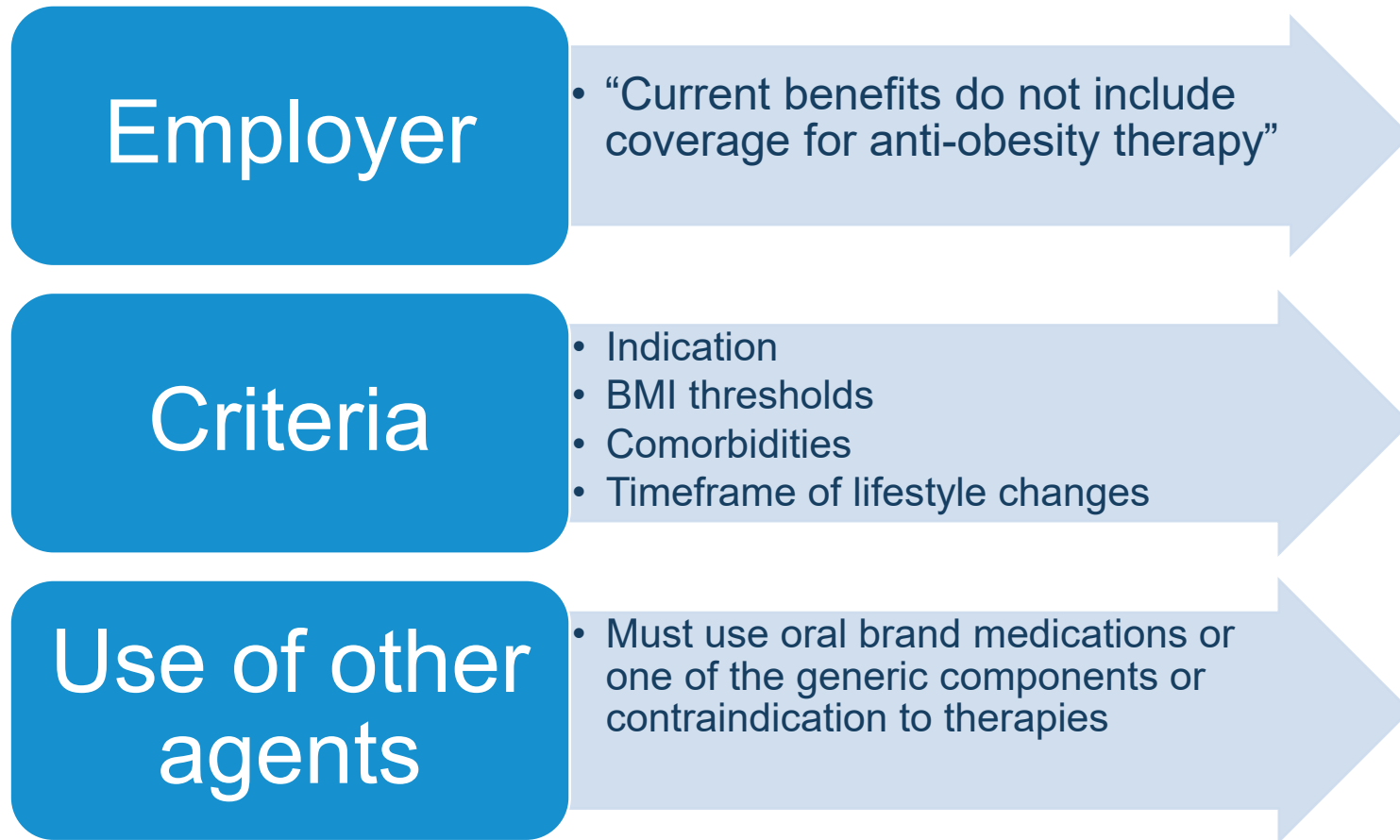

**Key to Success –Documentation!**

---

# Diabetes Data

---

# Guidelines – American Diabetes Association (ADA) Standards of Care in Diabetes 2025

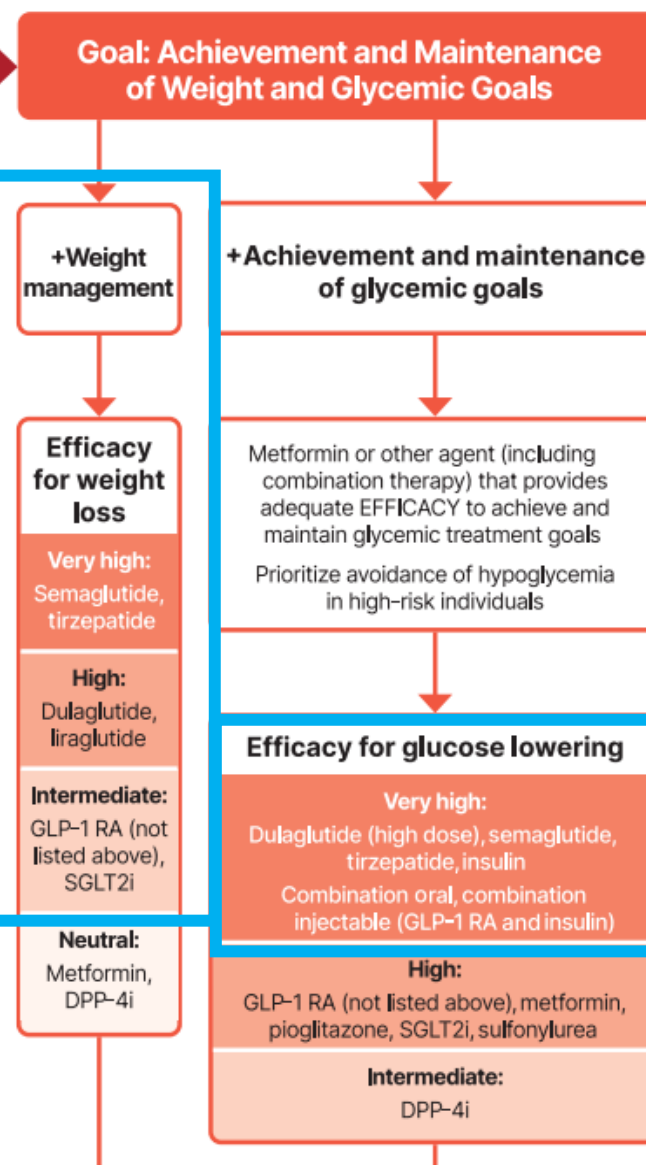
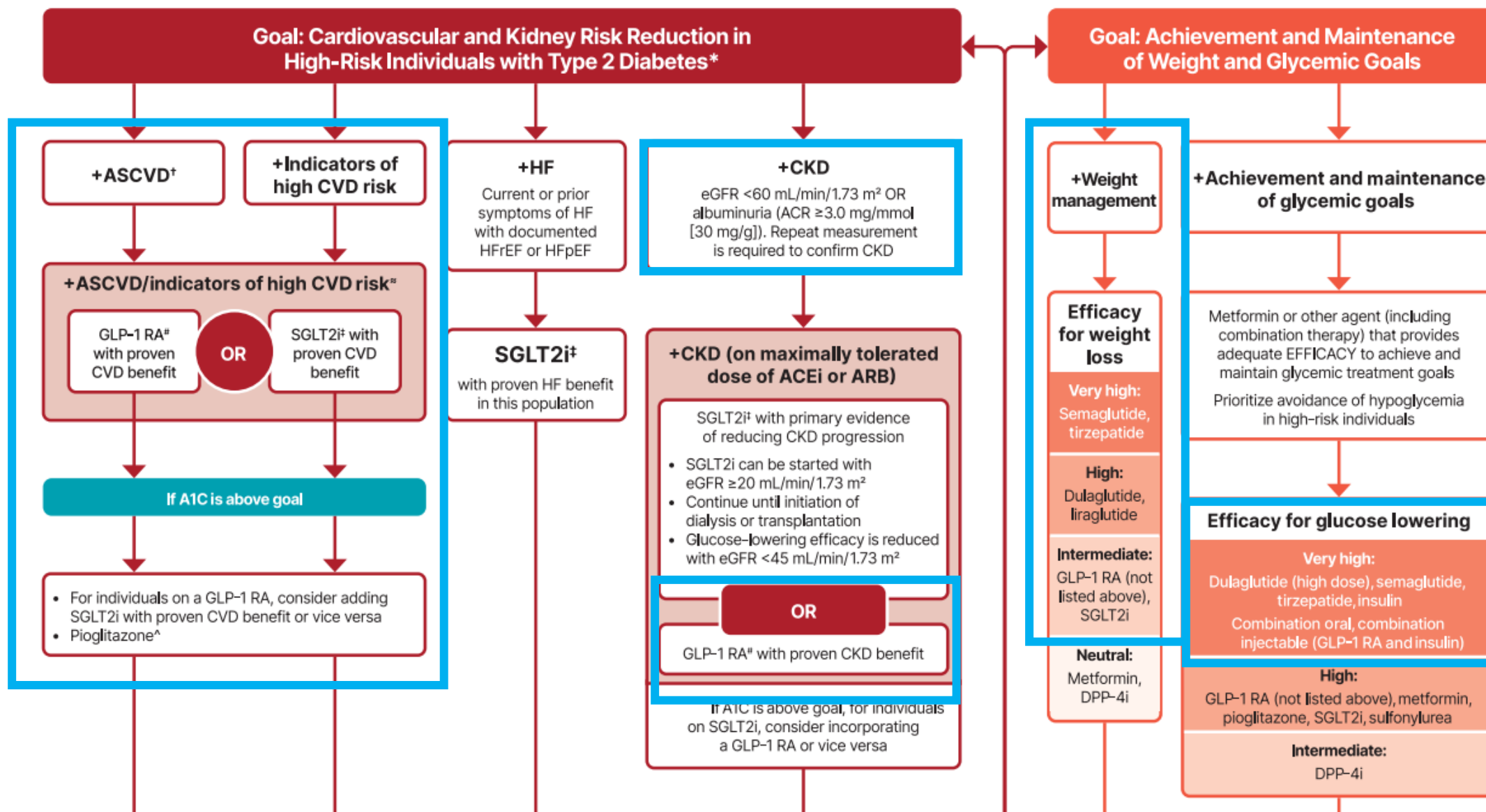

# GLP-1/GIP Agents Role In Therapy

Established or High Risk of ASCVD, HF and/ or CKD

- Should include agent(s) that **reduce cardiovascular and kidney disease risk** (e.g. SGLT2 and/or GLP-1) for glycemic management and comprehensive cardiovascular risk reduction
- **Independent of A1c and in consideration of patient-specific factors.** **A**

CKD

- CKD (with confirmed eGFR of 20–60 mL/min/1.73 m<sup>2</sup> and/or albuminuria)
- To reduce cardiovascular risk and kidney disease progression, a **GLP-1 with demonstrated benefit in this population** is recommended. **A**

Advanced CKD

- eGFR < 30 mL/min/1.73 m<sup>2</sup>
- **GLP-1 is preferred** for glycemic management due to lower risk of hypoglycemia and for cardiovascular event reduction. **B**

Weight and/or A1c ≥ 1.5% above goal

- **GLP-1/GIP agent preferred to insulin, when possible.** **A**
- If used with insulin, combination with GLP-1/GIP agent is recommended for greater glycemic effectiveness as well as **beneficial effects on weight and hypoglycemia risk.** **A**

# GLP-1/GIP Agents A1c Reduction and Benefits

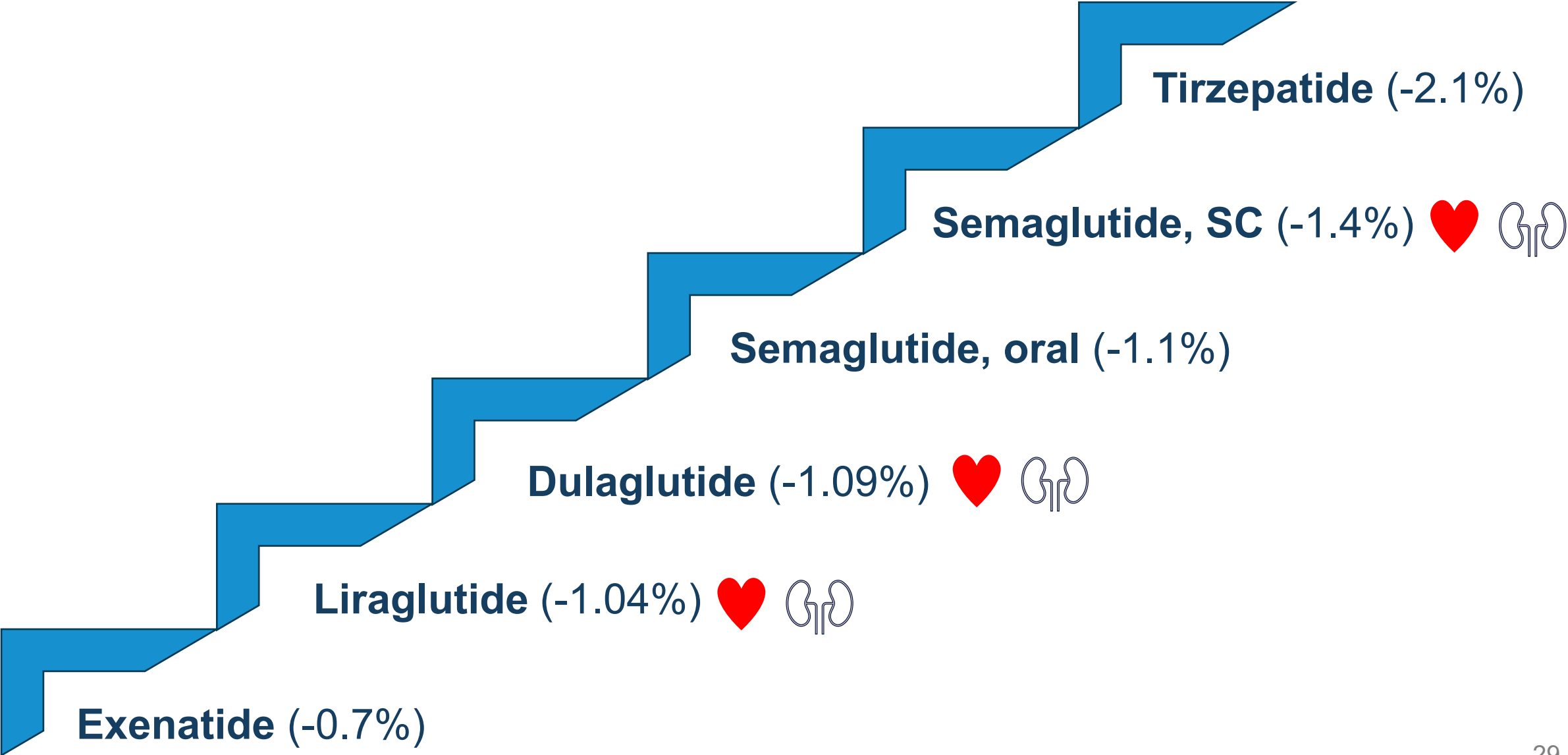

Clinical Resource. Comparison of GLP-1 Agonists. Pharmacist's Letter/Pharmacy Technician's Letter/Prescriber Insights. August 2024.

# GLP-1/GIP Agent Dose Comparison

**TABLE 4** GLP-1 Receptor Agonist Drug Shortages and Suggested Comparative Doses for Treating Type 2 Diabetes

Agent	Dosing Route and Interval	Comparative Doses				
Exenatide	SC twice daily	5 µg*	10 µg			
Lixisenatide	SC once daily	10 µg*	20 µg			
Liraglutide	SC once daily	0.6 mg*	1.2 mg	1.8 mg		
Exenatide XR	SC once weekly			2 mg		
Dulaglutide	SC once weekly		0.75 mg <sup>a*</sup>	1.5 mg <sup>a</sup>	3 mg <sup>b†</sup>	4.5 mg <sup>b†</sup>
Semaglutide	SC once weekly		0.25 mg <sup>b*</sup>	0.5 mg <sup>b</sup>	1 mg <sup>a</sup>	2 mg <sup>a‡</sup>
Semaglutide	PO once daily	3 mg*	7 mg	14 mg		
Tirzepatide	SC once weekly			2.5 mg <sup>a*</sup>	5 mg <sup>a‡</sup>	7.5 mg <sup>a</sup> 10 mg <sup>a</sup> 12.5 mg <sup>a</sup> 15 mg <sup>a</sup>

According to the FDA's drug shortage database as of 10 March 2023 (2), patients may have limited or intermittent access in community pharmacies to three agents in varying doses: dulaglutide, injectable semaglutide, and tirzepatide. <sup>a</sup>Drug doses that are currently in short supply but still available. <sup>b</sup>Drug doses with only limited or intermittent availability. \*Comparative efficacy of starting doses is not known and based on the clinical judgement of authors. †Based on information from ref. 33. ‡Based on information from ref. 35. PO, by mouth; SC, subcutaneous.

# Cardiovascular Benefits Summary

- FDA Approved Indication for Major Cardiovascular Events (MACE):
  - Liraglutide, Dulaglutide, Semaglutide (SC)
- 3-point MACE: stroke, nonfatal MI, CV death

Drug	Trial	Population	Primary composite CV Outcome HR (95% CI)	P-value	NNT
Liraglutide (Victoza®)	LEADER	CVD or CV risk	0.87 (0.78 to 0.97)	0.01	53
Dulaglutide (Trulicity®)	REWIND	CVD or CV risk	0.88 (0.79 to 0.99)	0.026	71
Semaglutide (Ozempic®)	SUSTAIN-6	CVD, CV risk, or CKD	0.74 (0.58 to 0.95)	0.02	44

# Kidney Benefits Summary

Drug	Trial	Secondary End Points	Secondary Outcome HR (95% CI)	P-value	NNT
Liraglutide (Victoza®)	LEADER	New macroalbuminuria or doubling of Scr + eGFR $\leq$ 45 mL/min, dialysis/transplant or death from kidney causes	0.78 (0.67–0.92)	0.003	83
Dulaglutide (Trulicity®)	REWIND	New macroalbuminuria, 30% decrease in eGFR, or dialysis/transplant	0.85 (0.77-0.93)	0.0004	40
Semaglutide (Ozempic®)	SUSTAIN-6	New macroalbuminuria or doubling of Scr + eGFR $\leq$ 45 mL/min, dialysis/transplant or death from kidney causes	0.64 (0.46–0.88)	0.005	44

*N Engl J Med.* 2016;375:311–322.

*Lancet.* 2019;394:121–130.

*N Engl J Med.* 2016;375:1834–1844.



# FLOW Trial

---

## *Effects of Semaglutide on Chronic Kidney Disease in Patients with Type 2 Diabetes (Evaluate Renal Function with Semaglutide Once Weekly)*

### **Inclusion Criteria:**

- A1c  $\leq 10\%$
- High risk CKD (eGFR 50-75 mL/min/1.73m<sup>2</sup> and ACR >300 and <5000 mg/g, OR eGFR 25 - <50 mL/min/1.73m<sup>2</sup> and ACR >100 and <5000 mg/g)
- Maximal tolerated dose of ACE/ARB

**Intervention:** semaglutide 1 mg weekly vs placebo

**Primary Outcome:** composite of kidney failure,  $\geq 50\%$  reduction in eGFR, kidney or CV death

# FLOW Trial

N= 3,533 and median follow-up of 3.4 years

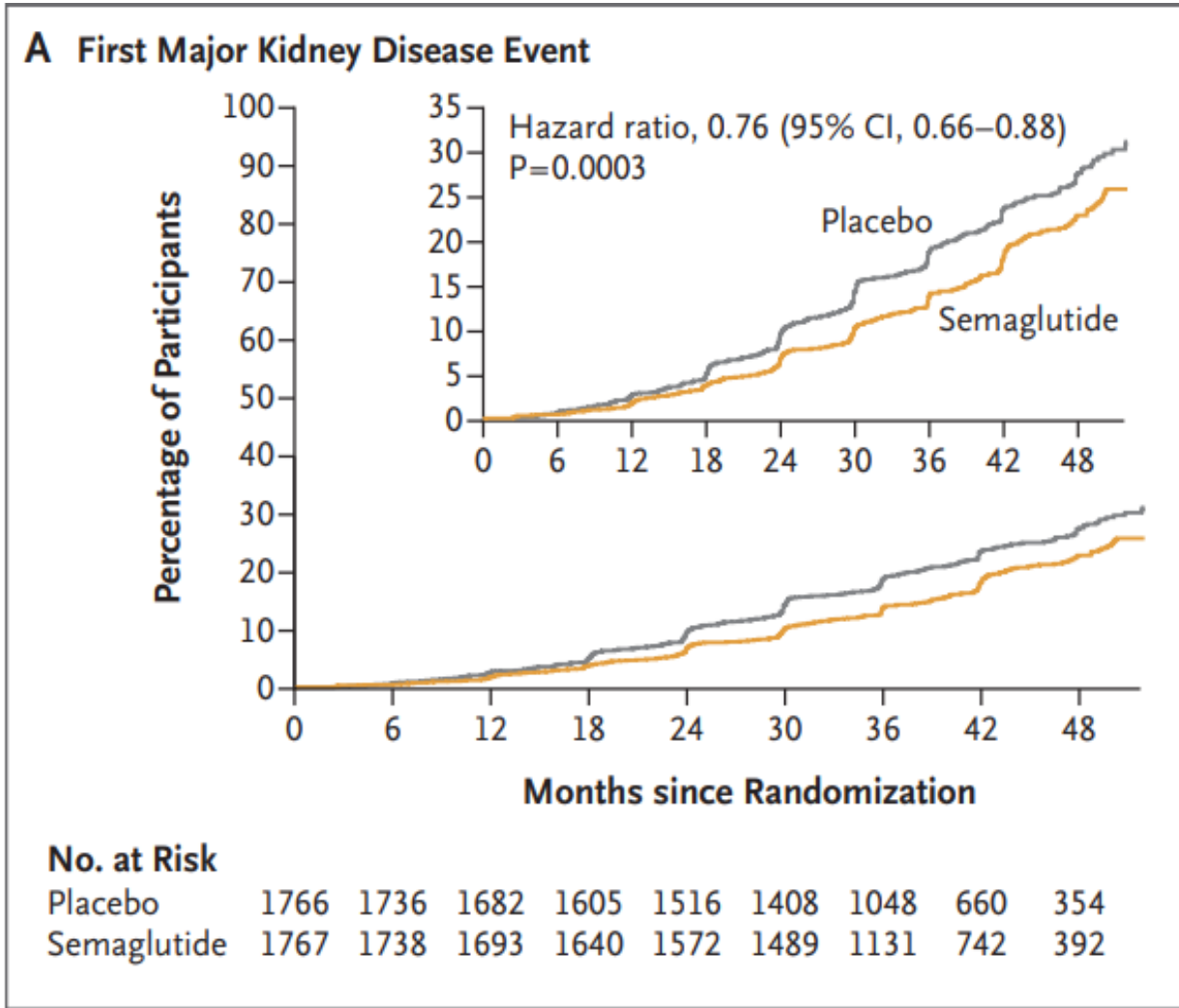

**Major Kidney Disease Events: HR 0.76 (95% CI, 0.66 to 0.88)**

Composite of Kidney-Specific Outcomes: HR 0.79 (95% CI, 0.66 to 0.94)

≥50% Reduction in eGFR: HR 0.73 (95% CI, 0.59 to 0.89)

Death from Kidney-Related Causes: 0.97 (95% CI, 0.27 to 3.49)

Death from CV Causes: 0.71 (95% CI, 0.56 to 0.89)

---

# **Additional Indications and Medications in the Pipeline**

---

# Additional Populations being Studied

Tirzepatide	Semaglutide
<ul style="list-style-type: none"><li>• Approved for Sleep Apnea*</li><li>• SURPASS-CVOT: Tirzepatide vs. dulaglutide on MACE with established CVD and T2DM</li><li>• Heart failure with preserved ejection fraction (HFpEF)</li><li>• Non-alcoholic steatohepatitis (NASH)</li><li>• Chronic kidney disease (CKD)</li><li>• Morbidity/mortality in obesity (MMO)</li></ul>	<ul style="list-style-type: none"><li>• Approved for Cardiovascular Risk Reduction*</li><li>• Alzheimer's Disease</li><li>• Metabolic dysfunction-associated steatohepatitis (MASH)</li></ul>  <ul style="list-style-type: none"><li>• * See supplemental slides for review of data</li></ul>



# Future weight loss medications

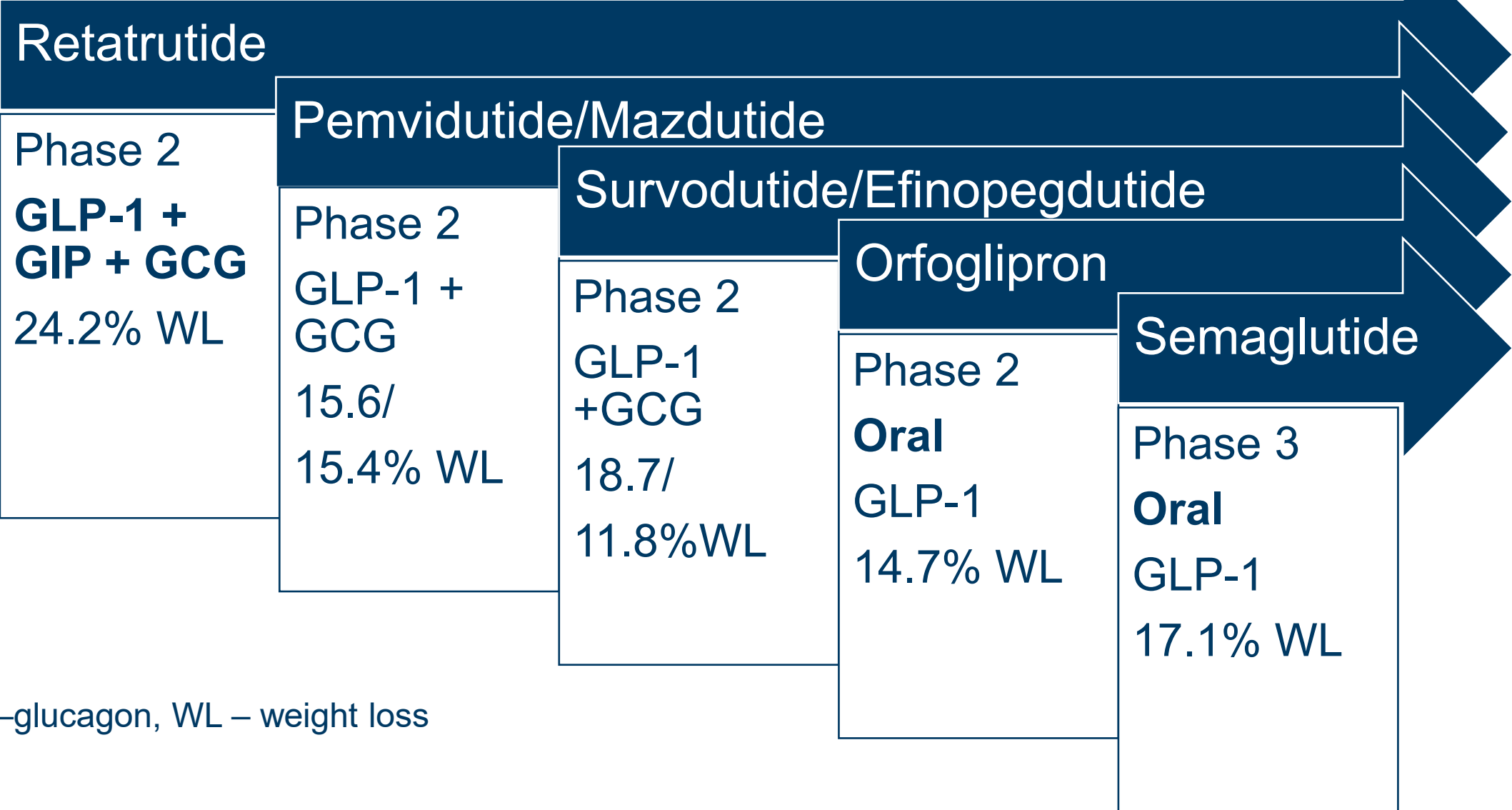

GCG –glucagon, WL – weight loss

---

# Patient Case

---

# Patient Case

---

A 59 year old female presents to office for an annual physical.

**Type 2 diabetes mellitus without complication, with long-term current use of insulin (HCC)**

A1c: 8.9%, 11/2022, will repeat today

- Current meds: Metformin 1000mg BID, Jardiance 25mg, Insulin (lantus) 38 units at night

- Interested in CGM Monitor, will follow up with pharmacist

Repeat A1c: 9.9%      Weight: 292lbs      BMI: 52.1

History of CAD, HTN, HLD, hx TIA, OA

Amlodipine 5mg daily

Atorvastatin 40mg daily

Carvedilol 25mg BID

Vitamin D3 1000 units daily

Furosemide 40mg daily PRN

Medication tried in past:

Victoza – stopped due to diarrhea

# Patient Case

Metformin 1000mg BID,  
Jardiance 25mg, **Lantus 10 units at night, Mounjaro 2.5mg weekly (74% reduction of insulin)**

**Plan:**  
**Increase Mounjaro to 5mg weekly**  
 Continue Jardiance 25mg daily  
 Continue Metformin 1000mg twice daily  
**Hold Lantus 10** when increasing dose

## AGP Report

November 24, 2023 - December 7, 2023 (14 Days)

LibreView

### GLUCOSE STATISTICS AND TARGETS

November 24, 2023 - December 7, 2023 **14 Days**

Time CGM Active: **29%**

Ranges And Targets For	Type 1 or Type 2 Diabetes
<b>Glucose Ranges</b>	<b>Targets % of Readings (Time/Day)</b>
Target Range 70-180 mg/dL	Greater than 70% (16h 48min)
Below 70 mg/dL	Less than 4% (58min)
Below 54 mg/dL	Less than 1% (14min)
Above 180 mg/dL	Less than 25% (8h)
Above 250 mg/dL	Less than 5% (1h 12min)
Each 5% increase in time in range (70-180 mg/dL) is clinically beneficial	

**Average Glucose** **123 mg/dL**

**Glucose Management Indicator (GMI)** **-**

**Glucose Variability** **20.7%**

Defined as percent coefficient of variation (%CV); target ≤36%

### TIME IN RANGES



### SUN Dec 3

Glucose mg/dL  
 Max  
 Min

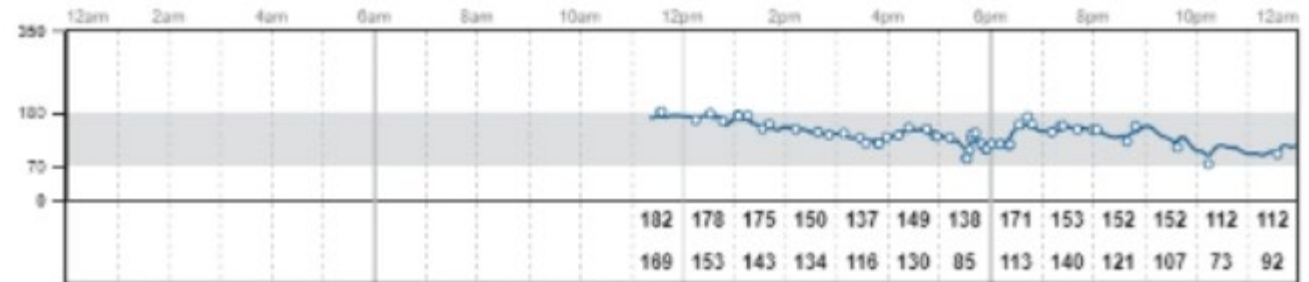

### MON Dec 4

Glucose mg/dL  
 Max  
 Min





# Patient Case

Metformin 1000mg BID,  
Jardiance 25mg, Mounjaro  
12.5mg weekly

No insulin

3/24 A1c: 6.4%

Weight: 243 lbs  
49 lbs loss  
16.8% reduction

## GLUCOSE STATISTICS AND TARGETS

August 1, 2024 - August 14, 2024 **14 Days**

Time CGM Active: **96%**

Ranges And Targets For	Type 1 or Type 2 Diabetes
<b>Glucose Ranges</b>	<b>Targets % of Readings (Time/Day)</b>
Target Range 70-180 mg/dL	Greater than 70% (16h 48min)
Below 70 mg/dL	Less than 4% (58min)
Below 54 mg/dL	Less than 1% (14min)
Above 180 mg/dL	Less than 25% (6h)
Above 250 mg/dL	Less than 5% (1h 12min)

Each 5% increase in time in range (70-180 mg/dL) is clinically beneficial.

**Average Glucose** **113 mg/dL**

**Glucose Management Indicator (GMI)** **6.0%**

**Glucose Variability** **15.4%**

Defined as percent coefficient of variation (%CV); target ≤36%

## TIME IN RANGES

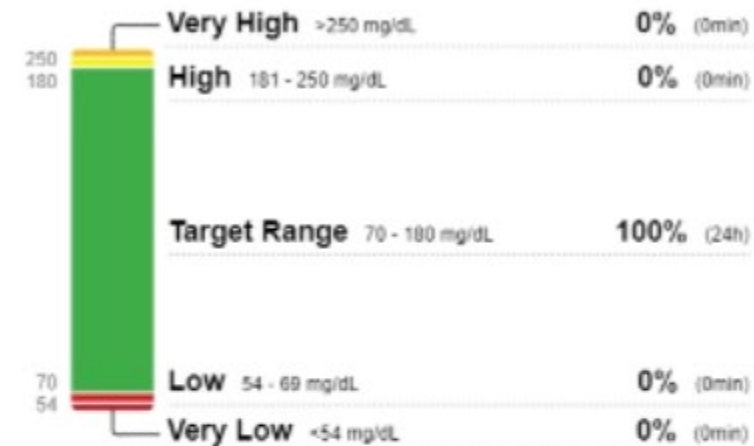

	Latest Ref Rng & Units	4/14/2021	11/21/2023	3/6/2024
Creatinine, Urine	mg/dL	99.4	70.5	44.4
Microralbumin, Random, Urine	mg/dL	4.3	<1.2	<1.2
Microalbumin/Creatinine Ratio		43.26 ▲	—	—

FRI Aug 9



SAT Aug 10

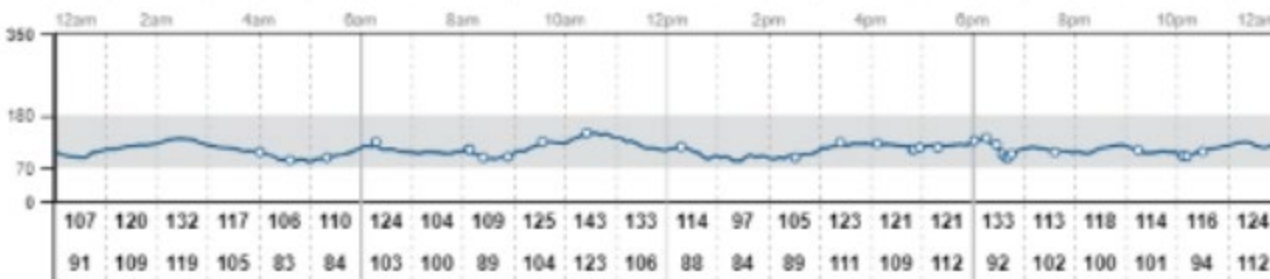

### Vitals from encounters over the past 365 days

	3/6/24	11/21/23
BP	122/78	152/89 !

Glucose mg/dL  
Max  
Min

# GLP-1s

There's a ton with GLP-1

Nicole Likar, PharmD, BCPS

Sarah Winter, PharmD, BCACP

---



# Obesity – Cardiovascular Risk Reduction - Semaglutide

- SELECT Trial N=17,606 patients
- 39 month trial of semaglutide 2.4mg vs placebo
- 45 years of age or older who had preexisting cardiovascular disease and a BMI  $\geq 27$
- A primary cardiovascular end-point event occurred in 569 patients (6.5%) in the semaglutide group and in 701 (8.0%) in the placebo group (hazard ratio, 0.80; 95% confidence interval, 0.72 to 0.90; P<0.001)

**A Primary Cardiovascular Composite End Point**

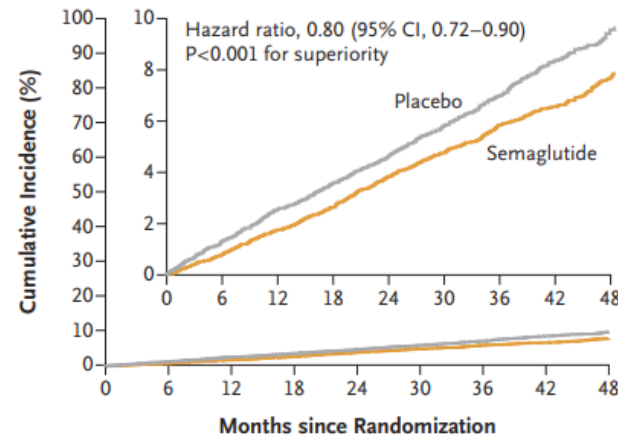

No. at Risk	
Placebo	8801 8652 8487 8326 8164 7101 5660 4015 1672
Semaglutide	8803 8695 8561 8427 8254 7229 5777 4126 1734

**B Death from Cardiovascular Causes**

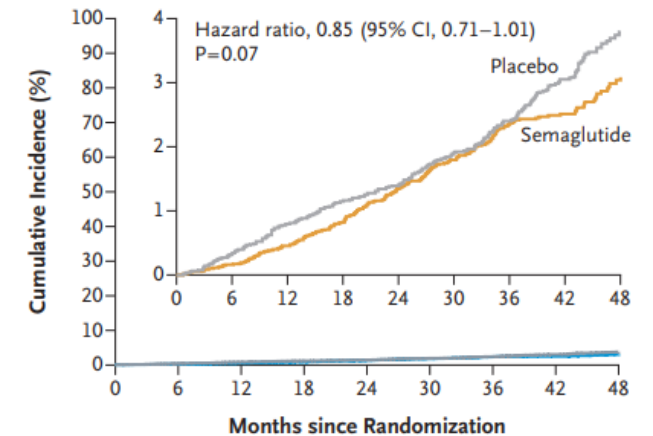

No. at Risk	
Placebo	8801 8733 8634 8528 8430 7395 5938 4250 1793
Semaglutide	8803 8748 8673 8584 8465 7452 5988 4315 1832

**C Heart Failure Composite End Point**

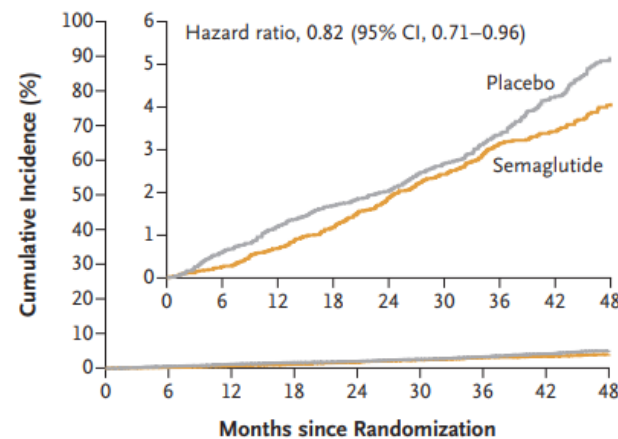

No. at Risk	
Placebo	8801 8711 8601 8485 8381 7341 5885 4198 1766
Semaglutide	8803 8740 8654 8557 8425 7409 5944 4277 1816

**D Death from Any Cause**

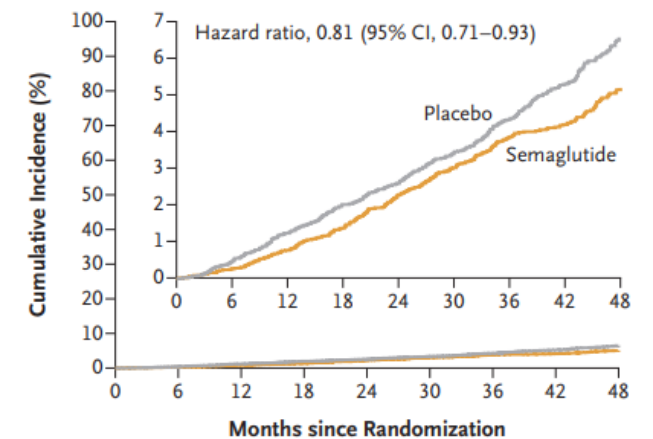

No. at Risk	
Placebo	8801 8733 8634 8528 8430 7395 5938 4250 1793
Semaglutide	8803 8748 8673 8584 8465 7452 5988 4315 1832

# Obesity – Sleep Apnea - Tirzepetide

- SURMOUNT-OSA
- Two 52 week trials with highest tolerated dose of tirzepetide vs placebo
- Moderate to Severe Sleep Apnea with Obesity
- AHI decreased significantly by up to 29.3 events per hour (a 58.7% change from baseline)

No PAP N=234

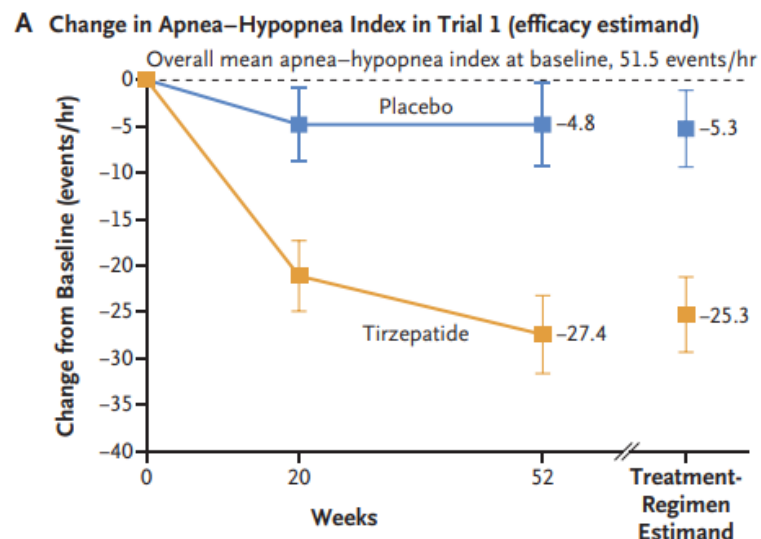

PAP N=235

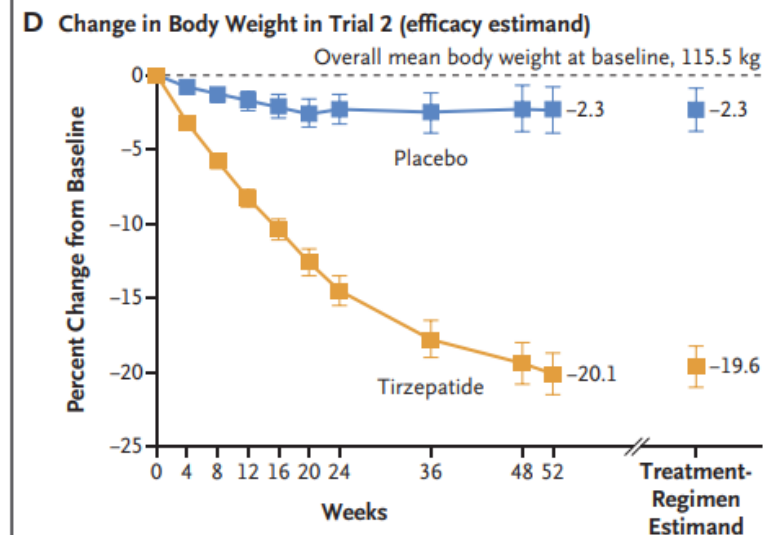
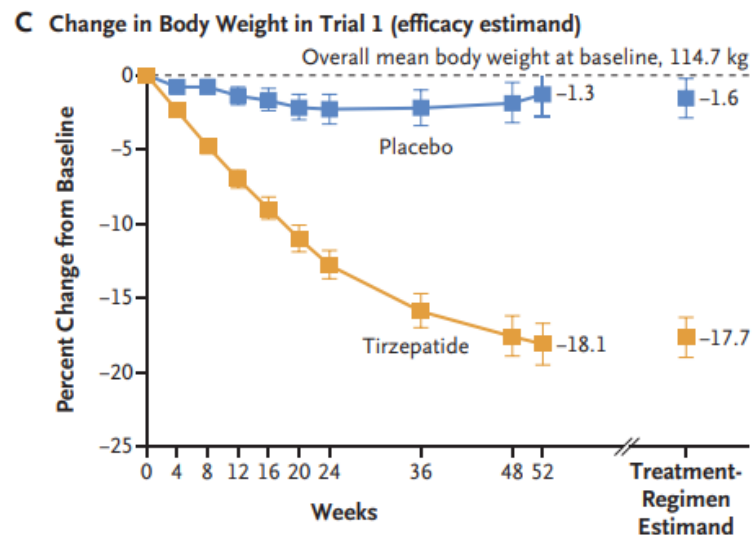
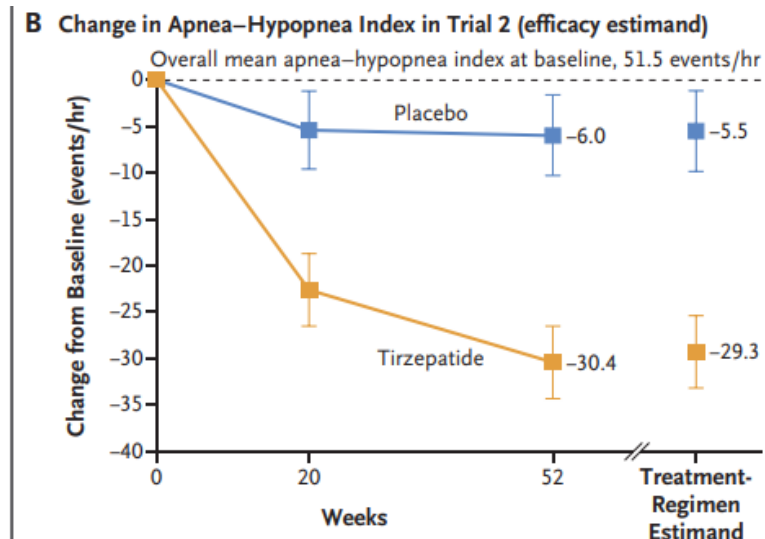



# Updates in Menopause

Martin Johns, MD

Program Director: UPMC Horizon Family Medicine  
Residency Program

Chair of Medicine: UPMC Horizon and UPMC  
Jameson Hospitals

# Objectives

- Improve knowledge and management of symptoms and conditions associated with menopause
- Understand the mechanism of action and new therapies for vasomotor symptoms of menopause
- Increase baseline understanding of options for hormone replacement therapy

# Definitions

- Menopause
  - Cessation of menses due to physiologic decrease in ovarian function
  - Diagnosed after 12 months of amenorrhea
- Perimenopause
  - The period immediately before menopause and the first year after the last menstrual period
  - Normal cycles + anovulatory cycles
  - Beginning of vasomotor symptoms
  - 3-5 years prior to menopause

# Onset

- Median age of menopause is 51 years
  - Earlier in smokers
- Considered premature if <40 years
  - Normal time can be between 40 and 60 years of age
- Perimenopause starts at 47 years on average
- Artificial menopause occurs due to surgery, chemotherapy, pelvic radiation
  - Risks for osteoporosis, heart disease, abnormal libido can start shortly thereafter



# Hormonal changes

- Decreased number of ovarian follicles leads to decreased estrogen production in the ovary
- Decreased negative feedback to the pituitary leads to increased FSH and LH levels
- FSH rises more than LH
  - 20-fold increase in FSH level, 3-fold increase in LH levels
  - Peak levels 1-3 years after menopause

# Hormonal Changes

- Androgen production continues in the ovarian stroma and adrenal glands
  - Androstenedione → estrone in fat cells
    - Obesity increases estrone levels
    - Higher risks of endometrial hyperplasia and breast cancer in obese women
- Progesterone levels also decline significantly contributing to irregular bleeding and endometrial hyperplasia

# Diagnosis

- Usually a clinical diagnosis
  - Associated symptoms + 1 year of amenorrhea
- Can test FSH (high) and Estradiol (low) levels to prove
  - Not necessary age >45
  - Helpful if <45 years
- FSH levels are measured
  - Anytime if no menses
  - Day 3 of cycle if still menstruating but having perimenopausal symptoms
  - Day 6 of placebo pills if taking OCPs and trying to determine discontinuation plans

# Clinical Signs and Symptoms

- Irregular volume, duration, and timing of menses
- Vasomotor symptoms (hot flashes, night sweats)
  - Insomnia
- Vaginal Dryness and dyspareunia
- Urinary incontinence / UTIs
- Memory loss (brain fog), fatigue, depression, mood swings, joint pain, decreased libido

# Opportunities for intervention

- Majority of women will go through many of these symptoms
  - Many won't bring them up
- A lot of misconceptions and fear over the last 20 years related to hormone replacement therapy
- Essential to introduce your willingness to address and treat your patient's symptoms

# Vasomotor Symptoms

- Up to 80% of women, lasting up to 10 years
- Sudden, transitory rushes of intense heat “like a furnace in my chest”
  - Hot flashes and Night Sweats
- Disruptive to sleep, productivity and wages, contribute to mood changes
- FDA study inclusion recommendations
  - 7-8 episodes of moderate to severe intensity daily
  - Over a several week period

# Vasomotor Pathophysiology

- Neurons in the central thermoregulatory zone of the hypothalamus
  - Express kisspeptin, neurokinin b, and dynorphin receptors (KNDy neurons)
- Estrogen inhibits these neurons and downregulates neurokinin receptors
- Decreasing estrogen increases neurokinin receptors which activate these neurons and promotes thermoregulatory dysfunction
- Several Neurokinin receptor antagonists are in development, one is FDA approved

# Fezolinetant (Veoza)

- Neurokinin-3 receptor antagonist
  - Blocks neurokinin-b from binding to thermoregulatory neurons
- 3 clinical trials—total 1,100 people
  - At least 7 vasomotor symptoms/day (moderate to severe)
  - Average age 53-55, max 65 years
  - Max trial length 52 weeks
  - Not studied in women who could not otherwise take hormones



# Fezolinetant Effectiveness

- 81-94% of patients on fezolinetant had a >50% reduction in the number of VMS/day
  - compared to 58% of placebo (placebo does well in most studies)
  - Reduction in severity of episodes as well
- Average improvement was 74-87% at 4, 12 weeks
  - 55% for placebo
- Estrogen: 80-90% of patients have a 90% reduction in VMS/day at 4 weeks

# Fezolinetant: Safety, Cost

- Contraindicated:
  - Cirrhosis, ESRD, Severe renal impairment
- Transient LFT elevations (2-3x ULN) in 2% of patients.
  - Resolved with stopping medication
- Requires LFTs at baseline, 3, 6, 9 months
  - Contraindicated with CYP1A2 inhibitors (fluvoxamine)
- Cost: \$540/month

# Estrogen Therapy

- Estrogen replacement therapy (90% effective)
  - Lowest effective dose
  - Must have some progestin if patient has a uterus (continuous or pulsed-dose)
- Oral, transdermal, vaginal forms
  - Vaginal dosing is generally not recommended for VMS symptoms
  - Alone or in combination with progesterone (oral and patches)
- Each formulation has multiple dosing options
- Limited comparable data across formulations
- Recommended to re-evaluate risks/benefits, symptoms and effectiveness regularly.

# Contraindications to Hormone Therapy

- Unexplained vaginal bleeding
- History of stroke
- Active estrogen-sensitive cancer
  - History of estrogen-sensitive cancer
- History of VTE
  - Personal History or Strong Family History of thromboembolism
- History of Coronary Artery Disease
- Active Liver Disease

# Additional Counseling

- Follow up and re-evaluate plan
- Heart Disease: no increased risk of death
- Osteoporosis: Decreased risk of fracture (but not first line treatment)
- Follow up and re-evaluate plan
- Breast Cancer: estrogen alone decreases risk of breast cancer, estrogen + progesterone increases risk by a very small amount, but no effect on mortality
- Diabetes: Decreased risk
- Follow up and re-evaluate plan

# Hormone Replacement Options

Medication	Delivery options	FDA approved indications
Estradiol (bioidentical)	Oral, transdermal patch, transdermal gel, transdermal spray, vaginal cream, vaginal ring, vaginal insert	Vasomotor symptoms, vulvovaginal atrophy, osteoporosis prevention (oral only), vaginal ring can be used for vasomotor symptoms
Conjugated equine estrogen	Oral, vaginal cream	Vasomotor symptoms, vulvovaginal atrophy, osteoporosis prevention (oral only)
Conjugated equine estrogen / bazedoxifene (duavee)	Oral estrogen + SERM (no progesterone needed)	Vasomotor Symptoms, osteoporosis prevention
Conjugated equine estrogen/medroxyprogesterone	Oral	Vasomotor Symptoms, vulvovaginal atrophy
Estradiol/norethindrone	Oral, transdermal patch	Vasomotor symptoms, vulvovaginal atrophy
Estradiol/levonorgestrel	Oral, transdermal patch	Vasomotor symptoms, vulvovaginal atrophy
Estradiol/drosperinone	Oral	Vasomotor symptoms, vulvovaginal atrophy
Estradiol/ progesterone (Bioidentical)	oral	Vasomotor symptoms, vulvovaginal atrophy
Ethinyl Estradiol/norethindrone	Oral	Vasomotor symptoms, vulvovaginal atrophy

# Compounded Bio-identical Hormones

- Not FDA approved
- No studies of efficacy, No warning labels
- Possibly increased endometrial cancer risk
  
- Commonly used but should be avoided

# Other non-hormonal therapies

- SSRIs and SNRIs
  - Paroxetine mesylate 7.5mg (Only FDA approved SSRI/SNRI for VMS)
  - Citalopram, Escitalopram, Paroxetine
  - Venlafaxine and Desvenlafaxine
- Clonidine
- Oxybutynin
- Non-pharmacologic options
  - CBT: may decrease severity without decreasing frequency
- Not Recommended
  - Black cohosh—meta-analysis of six studies found a positive benefit but oversight of supplements is very limited
  - Acupuncture
  - Isoflavones
  - Compounded Estrogen / Estrogen-progesterone formulations



# Urogenital Symptoms

- Stress incontinence
- Dyspareunia
- Recurrent Urinary Infections
- Itching
- Vulvovaginal dryness

# Treatment of Symptoms

- Vaginal Moisturizers
- Vaginal Estrogen cream, insert, or ring
  - Estradiol or Conjugated Estrogen
- Oral ospemifene (SERM)
- Subjectively improves incontinence symptoms but does not improve objective incontinence testing parameters
  - Increased risk of urge incontinence

# Joint Aches and Pain

- As many as 50-60% of women report joint pain in the perimenopausal and postmenopausal period
- Important to ask about symptoms—this is an area for research and likely underdiagnosed
- Perform an appropriate workup for diffuse symptoms
- Observational studies have shown an improvement in symptoms with hormonal therapy

# Depression

- New-onset depression is more common in women in menopause transition than premenopausal
  - In one study 2.5 times more likely in a within-woman 8-year longitudinal study
- More common in a prior history of depression
- Treat with anti-depressants and/or CBT
- Studies are ongoing to use transdermal estrogen to prevent depression in the menopause transition

# Insomnia

- Mostly from hot flashes / night sweats
- More common even in the absence of VMS
- 30-50% of women during menopause transition will report sleep disturbances
- Sleep apnea, restless legs, anxiety and depression can all contribute and co-exist

# Testosterone Deficiency / Hypoactive Sexual Desire Disorder

- Decreased libido/arousal
- More common with surgical menopause as the ovaries continue to make androgens
- Treat with DHEA or testosterone replacement
  - Vaginal DHEA preparations are available

# Other symptoms

- Brain Fog /Cognitive function
- Menstrual migraines
- Breast pain
- Skin Changes
- Balance

# Summary

- Vasomotor Symptoms are extremely common and can be very debilitating
- Decreasing estrogen levels trigger upregulation of neurokinin receptors in the KNDy neurons of the hypothalamus
- Neurokinin receptor antagonists offer an effective, non-hormonal treatment –expect more medications on the market soon
- Women with moderate to severe symptoms should be offered treatment. Hormone replacement is the most effective option
  - Get comfortable with a couple of dosing /treatment options
- Follow up frequently and re-evaluate your treatment plan
  - Adjust doses, re-visit risk factors, avoid inertia



# References and additional resources

- US Preventive Services Task Force. Hormone Therapy for the Primary Prevention of Chronic Conditions in Postmenopausal Persons: US Preventive Services Task Force Recommendation Statement. *JAMA*. 2022;328(17):1740–1746.
- Cieri-Hutcherson, N et al. Systematic review of neurokinin-3 receptor antagonists for the management of vasomotor symptoms of menopause. *Menopause: The Journal of The Menopause Society* Vol. 31, No. 4, pp. 342-354
- Stuenkel, C. Compounded bioidentical hormone therapy: new recommendations from the 2020 National Academies of Sciences, Engineering, and Medicine. *Menopause: The Journal of The North American Menopause Society* Vol. 28, No. 5, pp. 576-578
- Cortés, Yamnia I. Diverse experiences of menopause. *Menopause* 32(3):p 278-280, March 2025.
- Santoro, N. Neurokinin receptor antagonists as potential nonhormone treatments for vasomotor symptoms. *Menopause: The Journal of The Menopause Society* Vol. 31, No. 10, pp. 923-925
- Crespo C, Erlich D. Fezolinetant (Veozah) for the Treatment of Menopause Symptoms. *Am Fam Physician*. 2024 Mar;109(3):273-274.
- Cohen D, Brown E. Hormone Therapy for Sexual Function in Postmenopausal Women. *Am Fam Physician*. 2024 Jun;109(6):516-517.
- Chang JG, Lewis MN, Wertz MC. Managing Menopausal Symptoms: Common Questions and Answers. *Am Fam Physician*. 2023 Jul;108(1):28-39
- Johnson K, Hauck F. Conjugated Estrogens/Bazedoxifene (Duavee) for Menopausal Symptoms. *Am Fam Physician*. 2016 Feb 15;93(4):307-14

# Osteopathic Approach to Low Back Pain

---

Park Bateson, DO

Osteopathic Program Director UPMC Horizon  
Shenango Valley Family Medicine

# Objectives

---

- Review pertinent anatomy of the lumbar spine and how it can be associated with low back pain
- Review common causes of low back pain
- Review Fryette's Laws as they pertain to the lumbar spine
- Apply OMT to various causes of low back pain

# Facts about Low Back Pain

- 
- 31 million Americans suffer from low back pain
  - Affects 619 million people worldwide
  - LBP is the number one cause of disability worldwide
  - \$50 billion US dollars a year spent on medical costs for LBP
  - Can be experienced at any age, but prevalence increases with age. Highest number of cases occur between ages 50-55 years.
  - 80% of all people will experience low back pain at some point in their lives.
  - Non-specific LBP is the most common presentation (about 90% of cases).
    - Common risk factors include low physical activity levels, poor posture, smoking, obesity, and high physical stress at work, and improper lifting

# Lumbar Spine Anatomy

- 
- Lumbar spine consists of 5 vertebrae
  - Forms a smooth lordotic curve just above the pelvis
    - Typically extends from L2 to L5 with an average of about 43 degrees
  - Are the most massive segments of the vertebral column
  - Carries the weight of the upper half of the body
  - Occupies 1/2 to 2/3 of the posterior skeletal and myofascial wall of the true abdomen.
  - It is directly linked to the thoracic and pelvic regions.
    - Because of these anatomic connections, it can influence the head/neck, upper extremities, lower extremities, and the viscera.
    - The location of symptoms does not necessarily indicate the region of their etiology. Problems in the pelvis, abdomen, leg, arm, head, and thoracic regions as well as the lumbar regions.

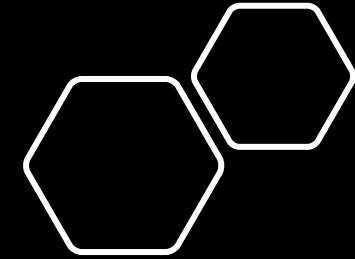
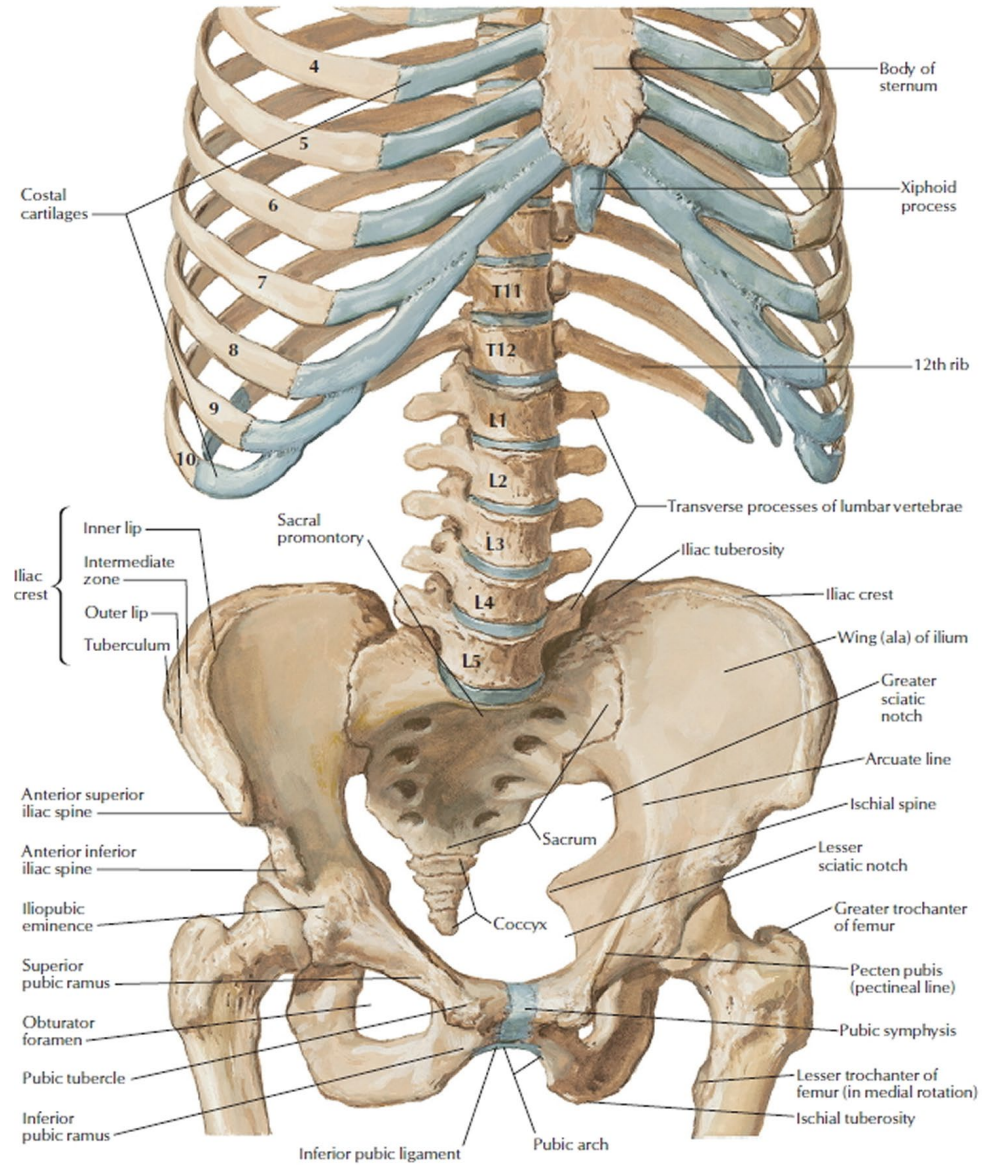

# Anatomy

- **Vertebral Bodies**

- Largest vertebral bodies in the vertebral column
- Distinguished by the absence of costal facets
- Is wider transversely and deeper anteroposteriorly than other vertebral body
- The large cross-sectional area and its longitudinal and vertical trabecular arrangement increases strength and stability.
- Also act as accessory organs for hematopoiesis



Location of lumbar vertebrae

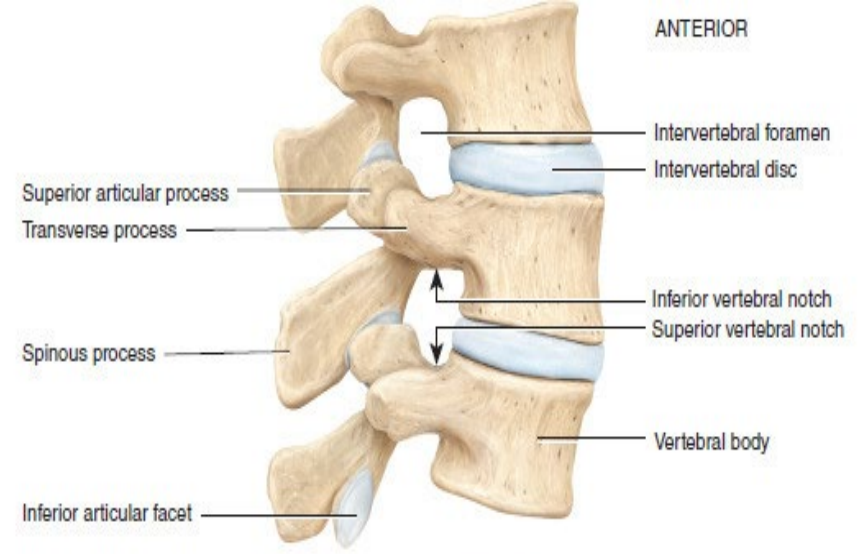

(a) Right lateral view of articulated lumbar vertebrae

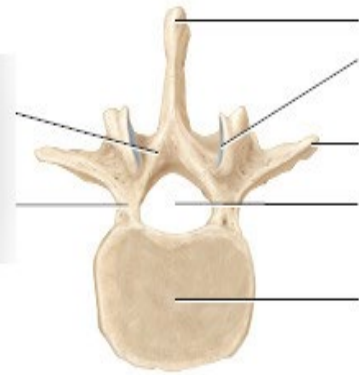

(b) Superior view

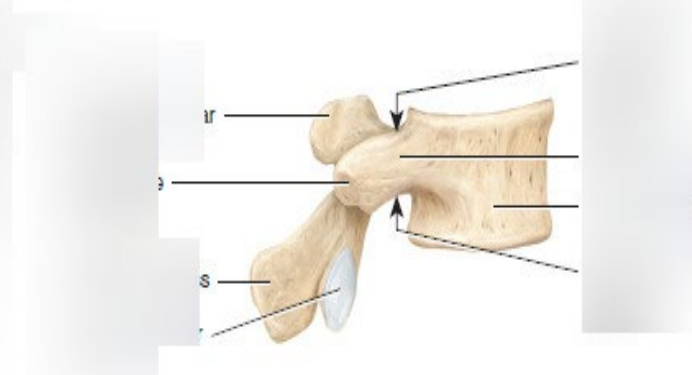

(c) Right lateral view

# Anatomy

---

- **Intervertebral Disk**

- Located between each lumbar vertebrae
- Are large and built to tolerate and dissipate heavy loads
- Composed of:
  - Glycosaminoglycans
  - Mucopolysaccharides
  - Proteoglycans
  - Collagen
- Each disk is jointed to the inferior plate of the vertebra above it and the superior plate of the vertebra below it.
- Separates each vertebrae from each other and provides the surface for shock absorbing
- The disks are innervated by fibers from an elaborate plexus supplied by the sinuvertebral nerve on the posterior longitudinal ligament and the somatosympathetic nerve on the anterior longitudinal ligament. In the early stages of compression, the SV nerve on the PLL is irritated giving rise to low back pain.
- Is composed of the nucleus pulposus and the annulus



# Anatomy

---

- **IV Disk cont:**

- **Nucleus pulposus** – is the gel-like center that is compressible and located at the center of the disk. It is surrounded by layers of the annulus.
  - composed of 70-90% water; is semifluid and hydrophilic
  - With postural weight bearing it expands laterally against the annulus working together mechanically to act as a shock absorber between each vertebral body.
- **Annulus** – outer fibrous ring
  - Composed of several layers of fibrocartilage of both type 1 and type 2 collagen; type 1 collagen is concentrated towards the outer edge of the ring where it provides the greatest strength.

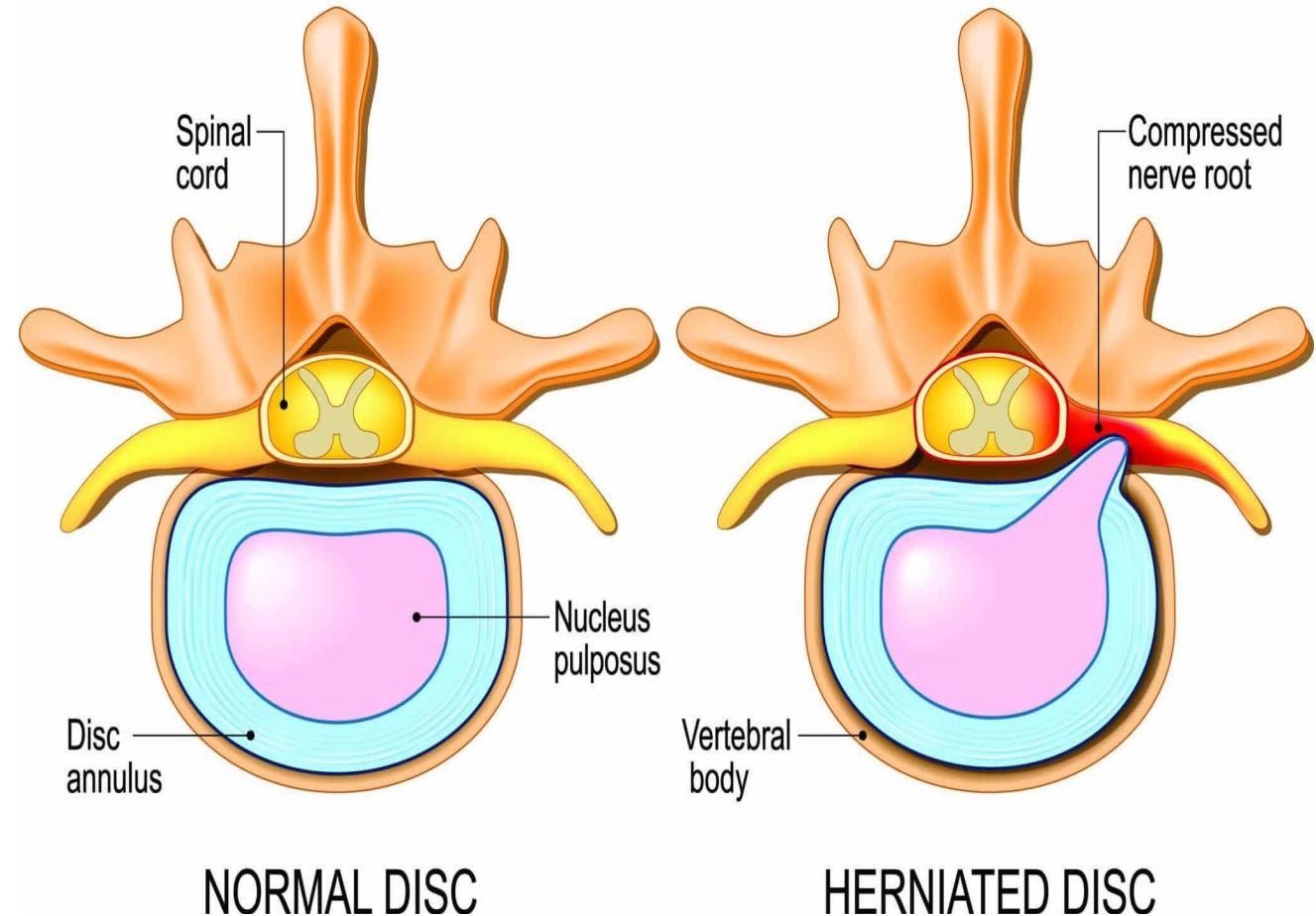

# Anatomy

- **Pedicles**

- Connects the posterior elements to the vertebral body and marks the site where the posterior vertebral elements begin.
- Protects the nerve root of a vertebral unit from being injured by a significantly herniated IV disk of that same unit.

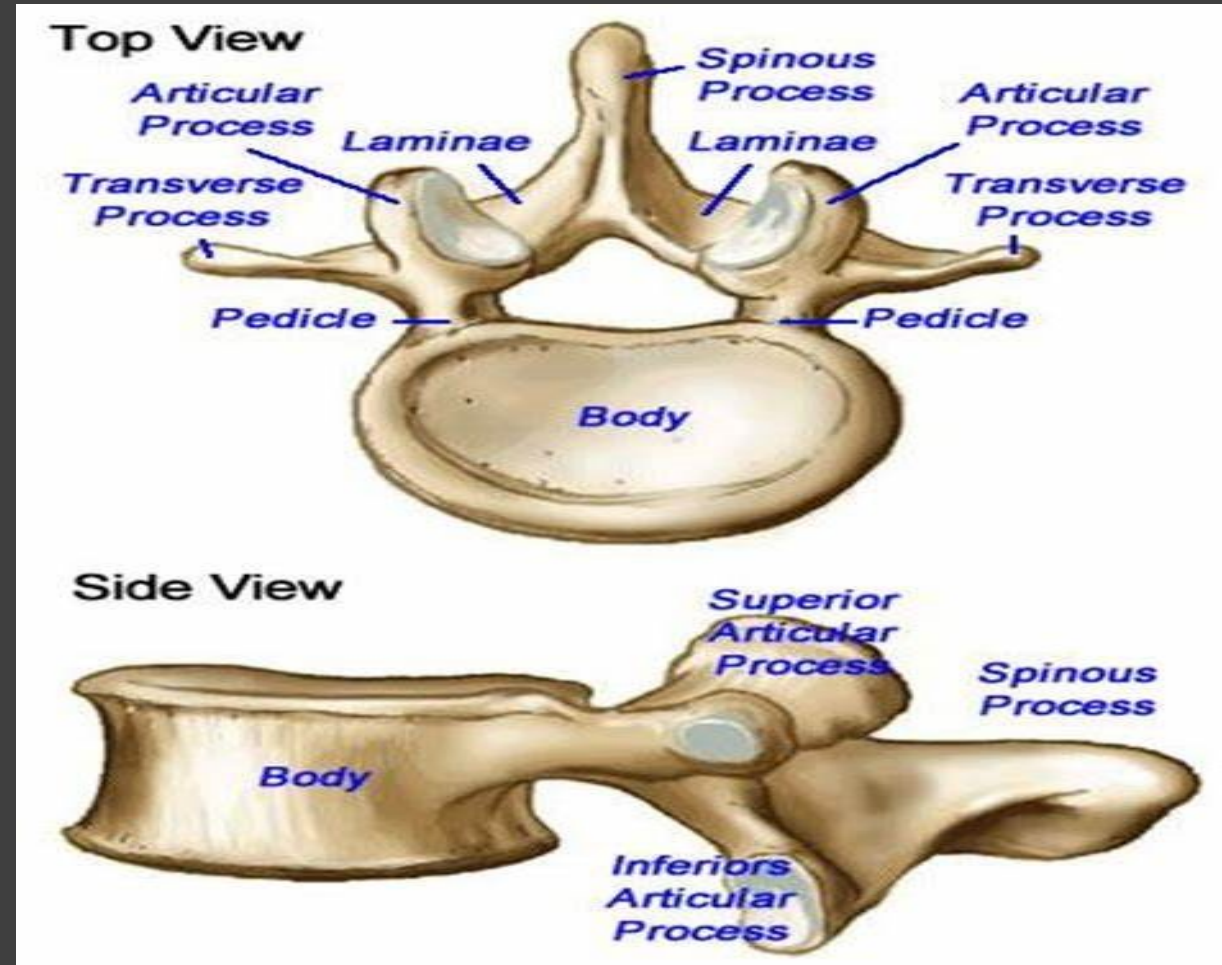

# Anatomy

- **Transverse Process**

- Projects laterally from the region of each pedicle
- In the lumbar region these processes are anatomically located directly lateral to the spinous process of the vertebra of their origin.
- Attachment sites of many of the trunk muscles (e.g. quadratus lumborum).

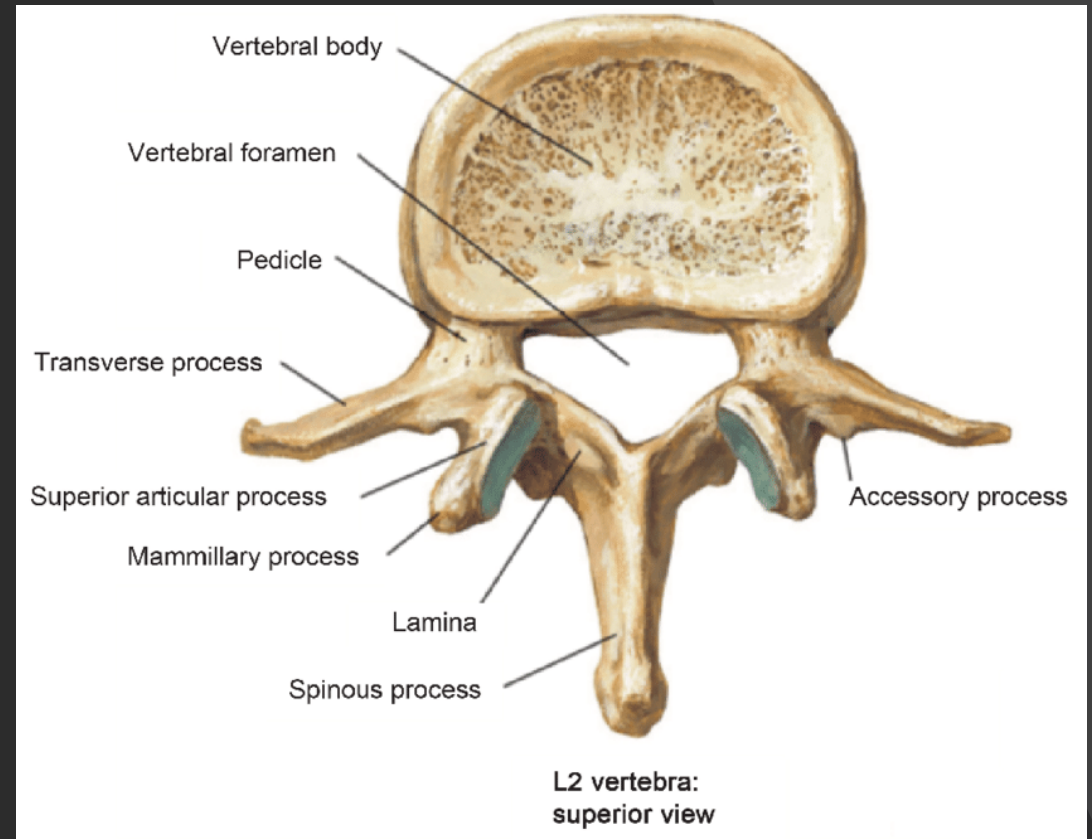

# Anatomy

- **Articular Processes**

- **Inferior articular process** projects in an inferior direction from the region of the pedicle, and its articular surface faces laterally
- **Superior articular process** projects superiorly from the same pedicle and its facet faces medially.
- The joint space of an intervertebral synovial joint is formed by the facet of an inferior articular process of one vertebra and the face of a superior articular process of the next.
- Each facet joint is innervated by 2 small nerves – paired **medial branches** of the posterior ramus of the spinal nerves.
  - Receives a medial branch from the spinal nerve above the facet and the nerve below.
  - Degeneration or inflammation within a facet joint creates a pain signal via the medial branch nerves. Is a cause of low back pain in adults.
  - These nerves do not control any muscles or sensations to the limbs

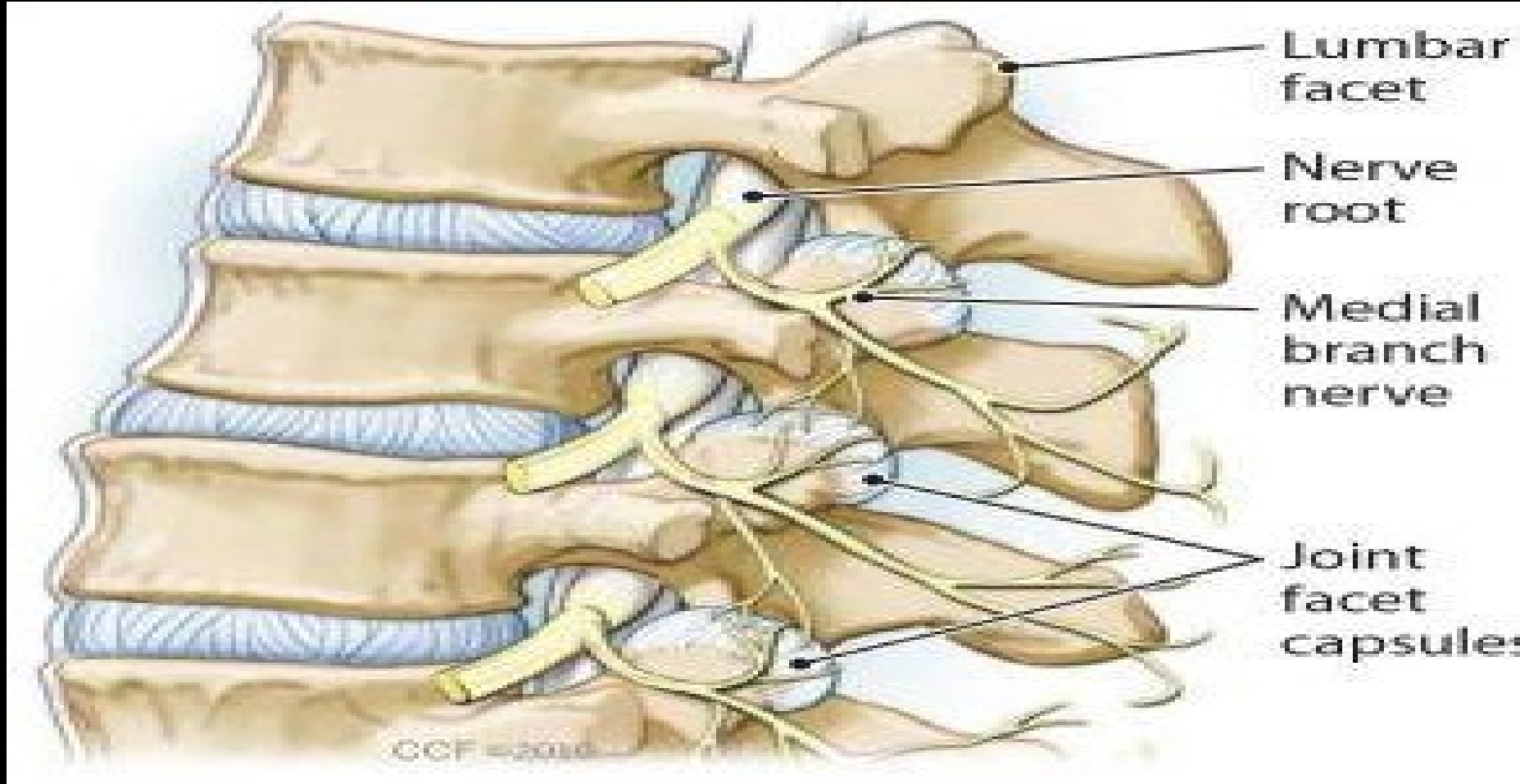

# Anatomy

- **Lamina**

- Projects medially and inferiorly from each pedicle and tends to meet its partner in the posterior midline to form a typical rectangular lumbar spinous process
- In some instances, the lamina will not completely meet in the mid-line causing a spina bifida.
- Most common anomaly is the “hidden” SB = spina bifida occulta. Frequently found at L5-S1 – the only physical clue to its presence may be a midline patch of coarse hair on a patient’s skin over its site. The skin is intact and no meningeal components. It may modify muscle attachments
  - **SBO** – no herniation through the defect – can treat with OMT – can be ligamentous asymmetry and abnormal loading stress; some reports of sacral base unleveling (may need heel lift). OMT – soft tissue, MFR, counter strain, balanced ligamentous tension.
  - **SB with Meningocele** – a herniation of the meninges/spinal fluid through the defect – no nerves affected but patients can have some minor trouble with bowel/bladder function.
  - **SB with Myelomeningocele** – a herniation of the meninges and the nerve roots through the defect. Is associated with neurological deficits – bowel and bladder incontinence, sensory/motor loss in the lower extremities or nerve root only involvement. Usually there is flaccid paralysis but if the spinal cord is involved then there is spastic paralysis.
    - Is the most severe form and infections are common with death during infancy due to sepsis

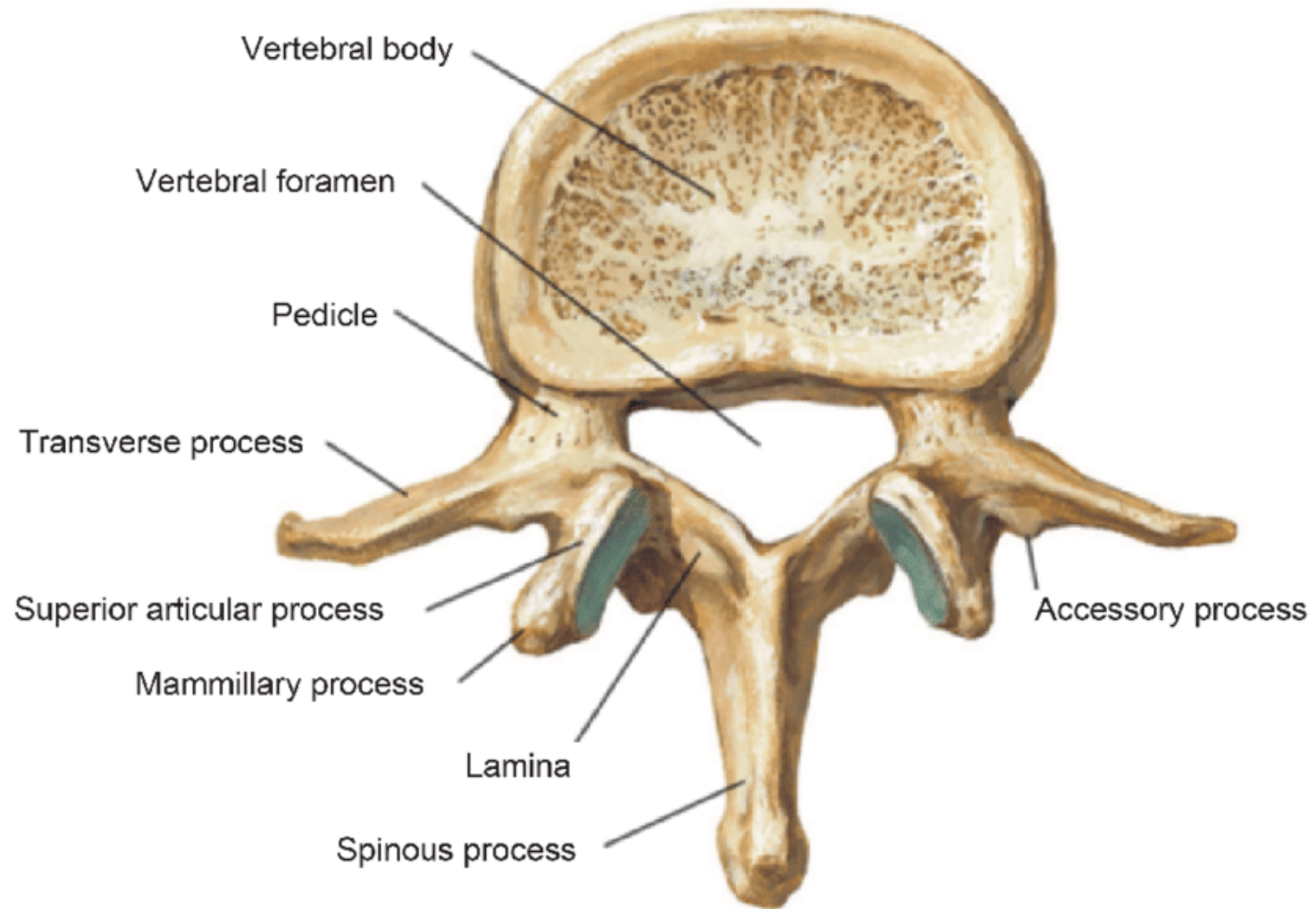

**L2 vertebra:  
superior view**

**Spina bifida occulta**

(opened posterior vertebral body)

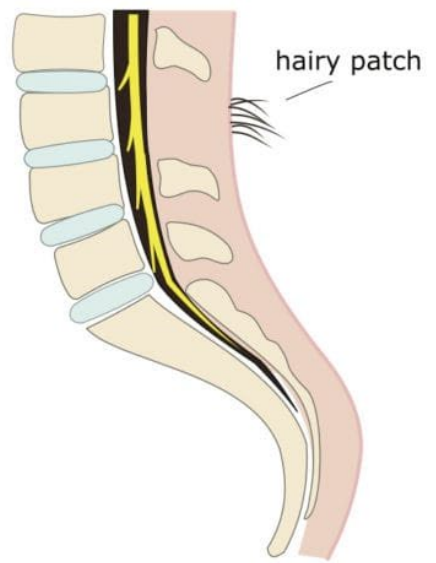

**Meningocele**

(protrusion of the meninges)

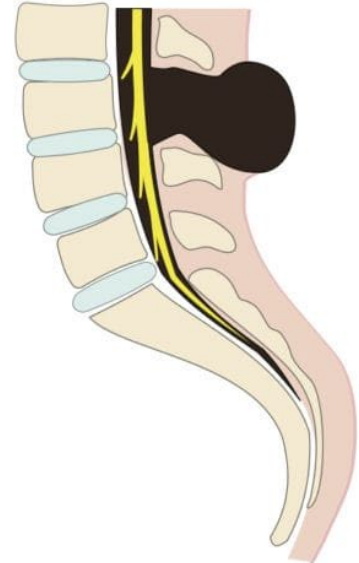

**Myelomeningocele**

(protrusion and opened spinal cord)

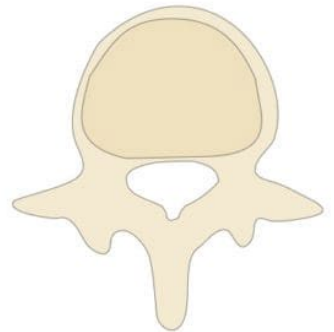
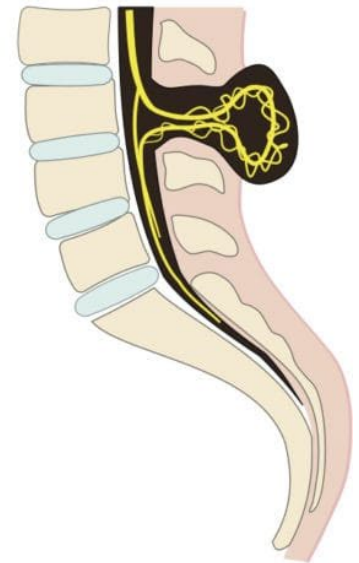

normal vertebra

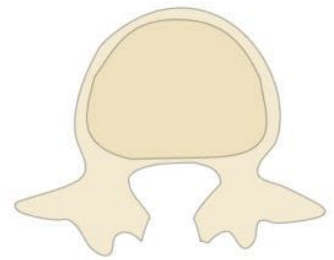

not completely closed vertebra



# Anatomy

---

- **Spinus Process**

- Lumbar SP's are distinguished by their palpable, thick, quadrangular, and “spade-like” distal ends.
- The only exception is the SP of L5 which is smaller, lies in a hollow just above the sacral base, and its distal end is about 1/3 smaller than the rest of the lumbar spine. It feels more like a thoracic SP rather than a lumbar SP.
- Project posteriorly and often inferiorly from the laminae.
- Shape provides palpatory evidence of where the lumbar region begins and where the thoracic spine ends.
- Functions as a series of levers for both muscles of posture and muscles of active movement. Most muscles that attach to the SP act to extend the spine.
- Also serve as attachment sites for ligaments

# Anatomy

---

- **Intervertebral Foramina**

- One on either side (left and right).
- Formed by two adjacent vertebrae of a vertebral unit
  - 2 adjacent vertebral bodies and the IV disk between them
  - 2 adjacent pedicles
  - The inferior articular process of one vertebra and the superior articular process of the next, including the synovial joint between them
- A spinal nerve and a recurrent meningeal nerve pass through the lumbar foramen. The nerve will exit below its corresponding vertebrae.
- A lumbar foramen is normally 2-3x large than the area taken up by the lumbar nerves, so it seems that compression of the nerve would be difficult.
- With flexion, the facets and pedicles glide away from the one another, and the size of the IV foramen increases.
- With extension, the pedicles glide toward one another, and the foramen is reduced in size.
- Reduction of the foramen size also results from: arthritis/spurs, hypertrophy of the posterior longitudinal ligament, extrusion of the nucleus pulposus, tissue congestion or edema, inflammation, perineural edema.
  - Removal or reduction of the effect produced by any of these factors may be enough to allow a symptomatic patient to be asx, pain free and able to work.

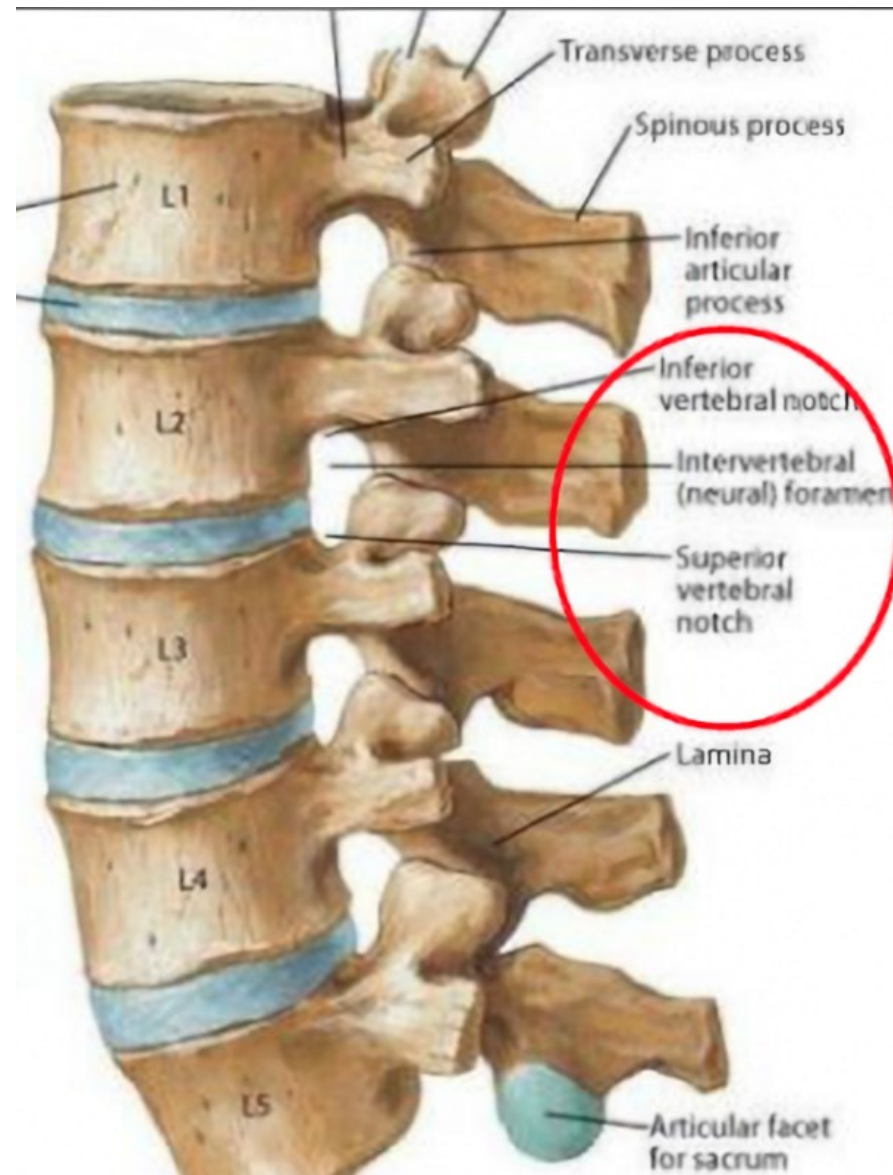

# Muscles

---

## Anterior Muscles

### **Psoas Major**

Abdominal muscles

- rectus abdominis
- external and internal obliques
- transverse abdominis

## Posterior muscles

**Superficial** – Latissimus dorsi and Serratus posterior inferior

**Intermediate Muscles – Erector spinae**

• **Spinalis, Longissimus, and Iliocostalis**

**Deep Muscles –**

- Transversospinalis
- rotatores, multifidus, semispinalis
- **Quadratus lumborum**

# Anterior Muscle Group

## PSOAS MUSCLE

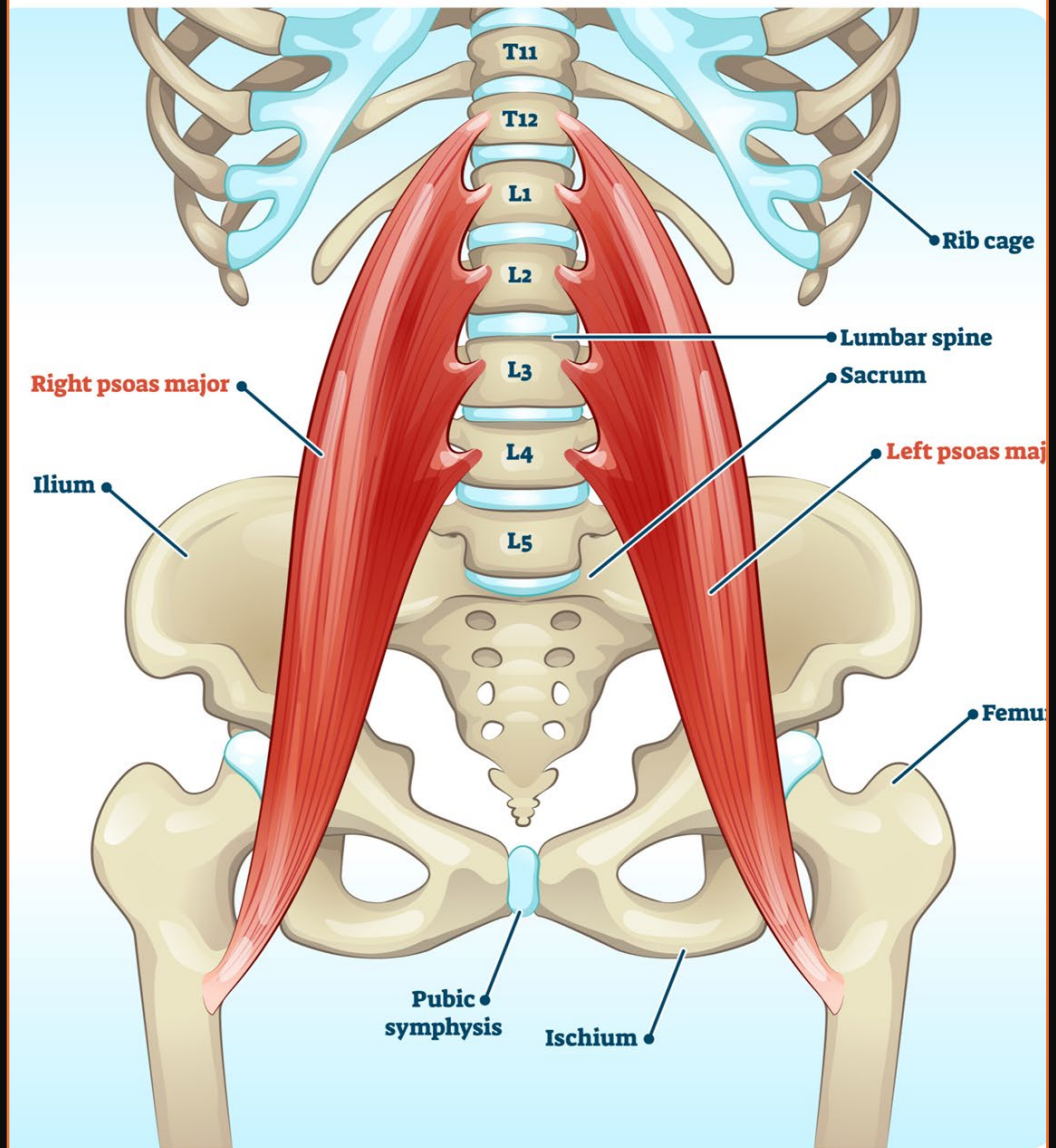

## Superficial Posterior Muscle Group

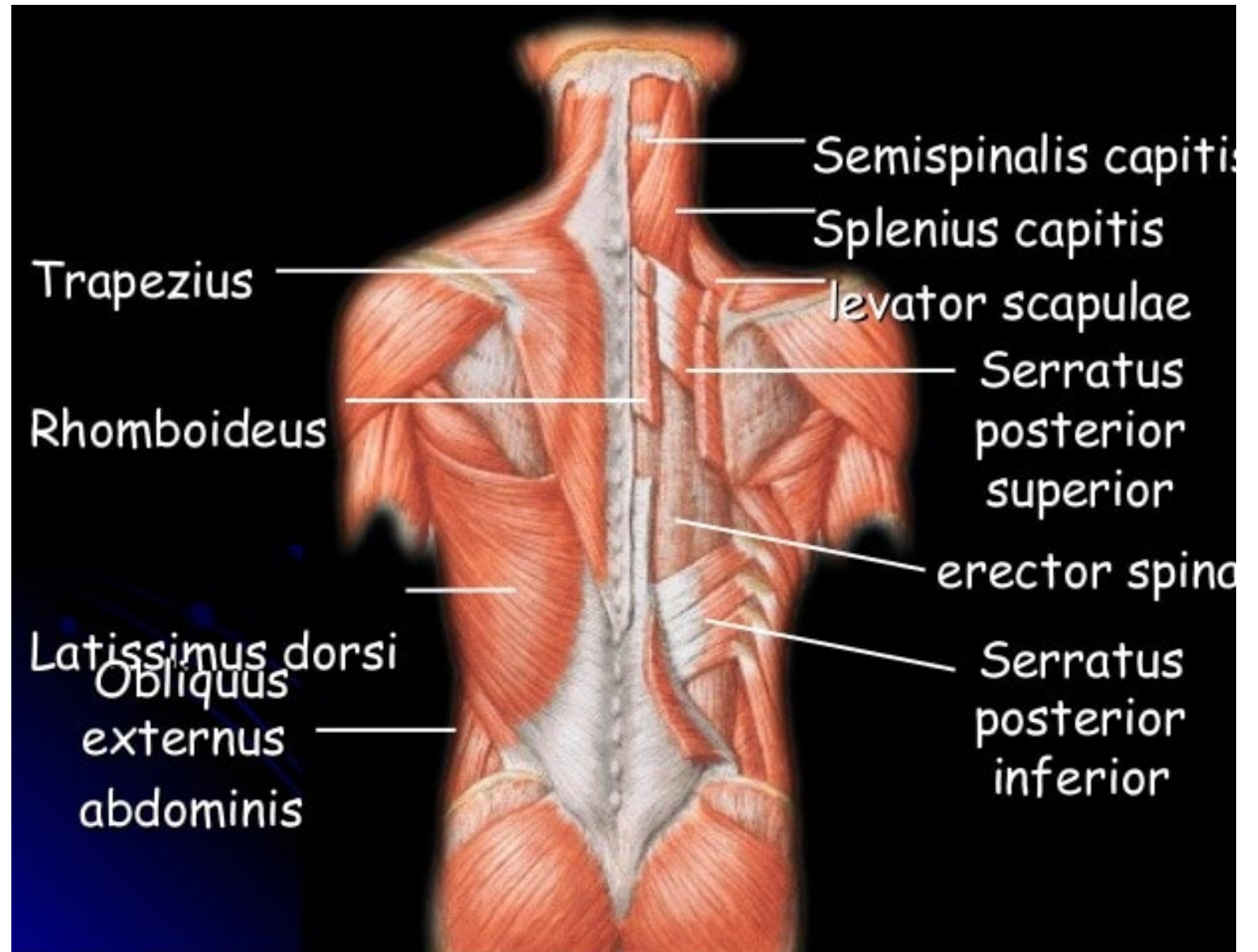

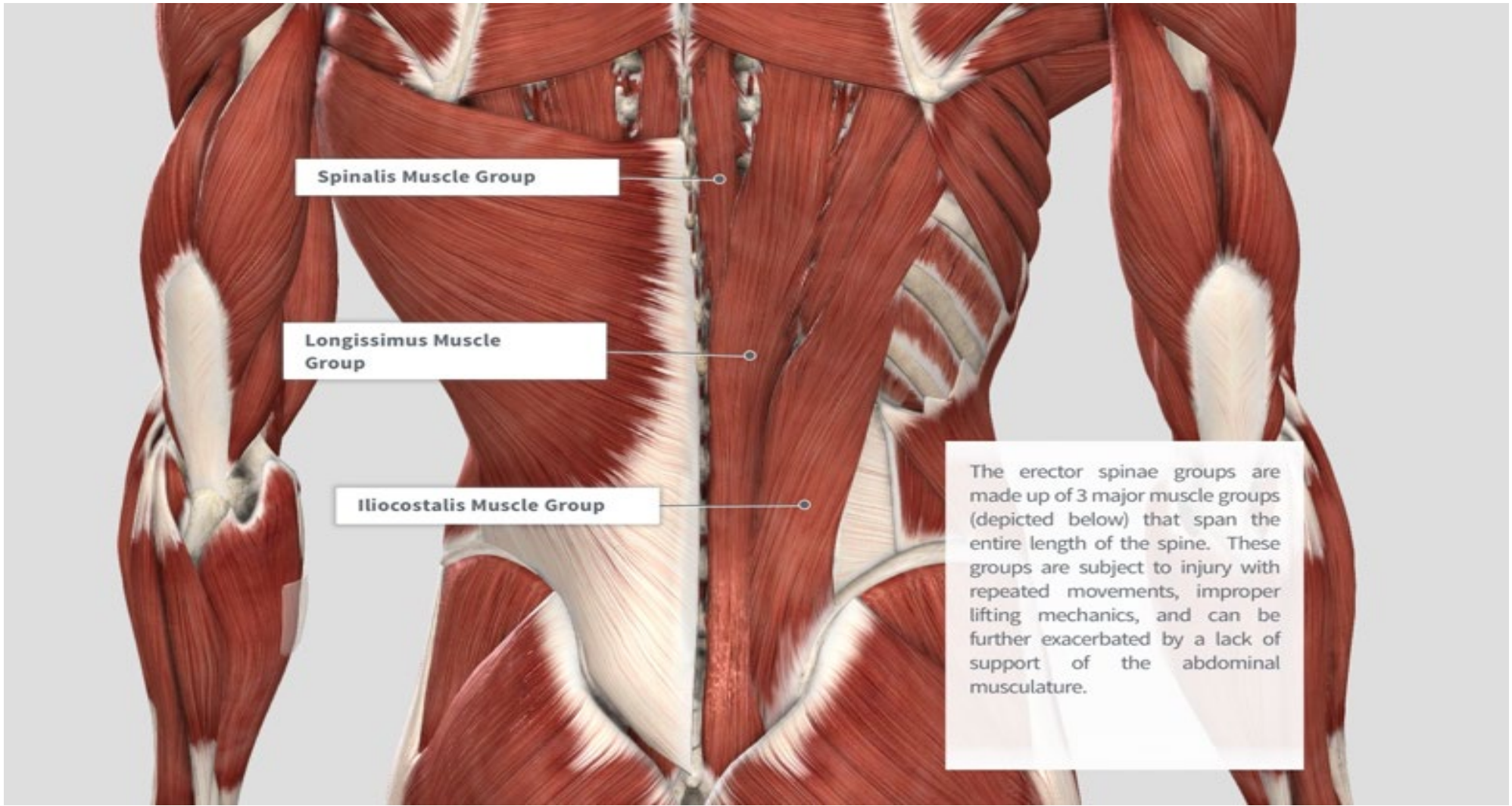

**Spinalis Muscle Group**

**Longissimus Muscle Group**

**Iliocostalis Muscle Group**

The erector spinae groups are made up of 3 major muscle groups (depicted below) that span the entire length of the spine. These groups are subject to injury with repeated movements, improper lifting mechanics, and can be further exacerbated by a lack of support of the abdominal musculature.

# Ligaments

---

- Form a continuous, dense connective tissue stocking that houses the lumbar vertebrae and sacrum
- Provide attachment sites for associated muscles
- Provides a self-bracing mechanism of the pelvis, a mechanism that functions to maintain the integrity of the low back and pelvis during the transfer of energy from the spine to the lower extremities.



# Ligaments

---

- **Ligamentum Flavum**

- “Yellow Ligament”
- Attaches the posterior elements of each vertebra together.
- Runs from each pedicle and lamina to the next and makes up the posterolateral boundary of the neural foramen. It makes up the covering of the spinal canal
- Thickening and calcification can cause foraminal narrowing, spinal stenosis, and nerve root compression
- Is the main opposition to flexion loading of the lumbar spine and can be injured with excessive spinal flexion.
- Little to no regenerative ability thus a damaged ligament is replaced by dense connective tissue.

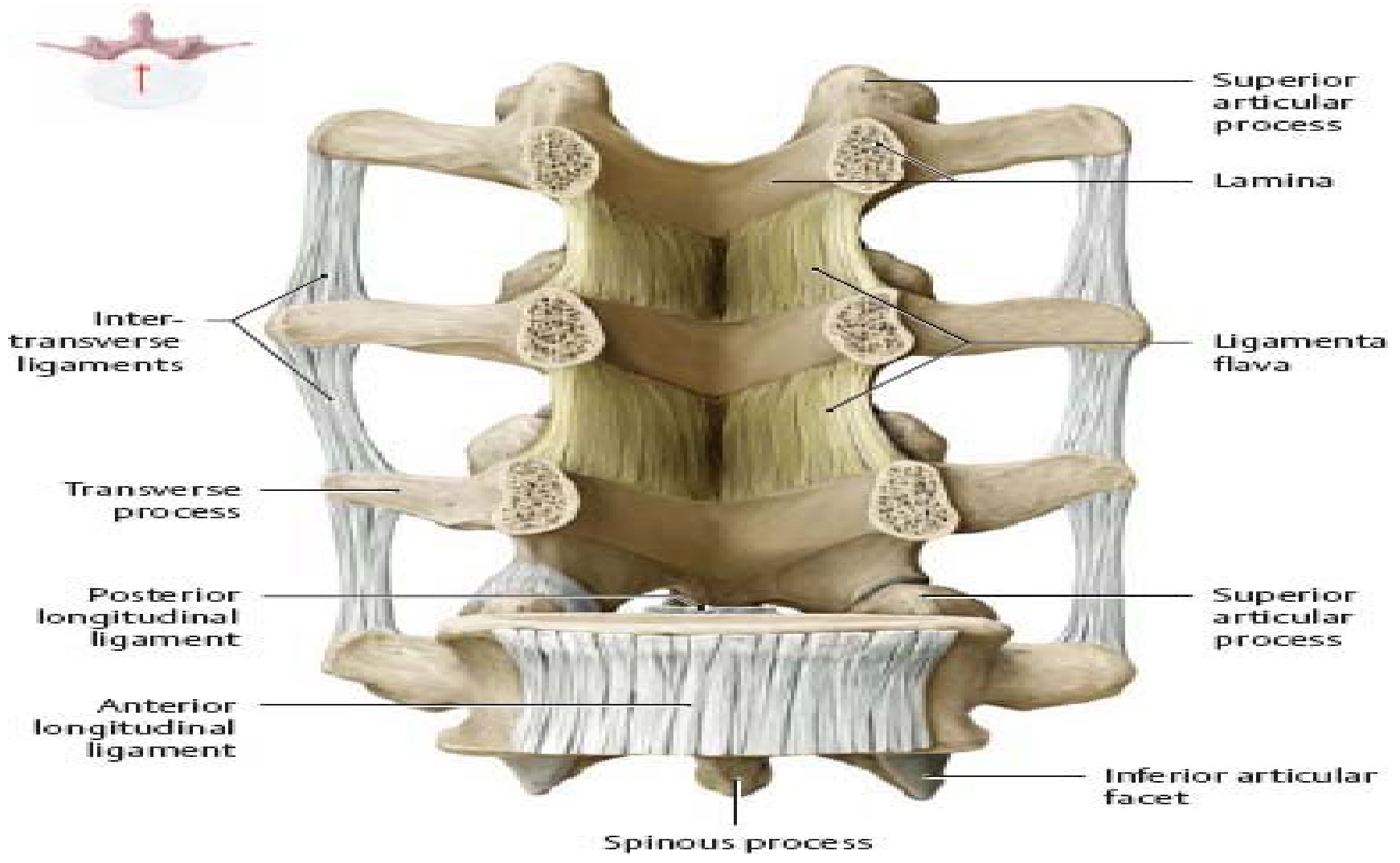

# Ligaments

## Interspinous Ligament

- Anchors the thoracolumbar fascia and multifidus sheath to the facet joint capsules
- Central support system for the lumbar spine

## Anterior Longitudinal Ligament

- Courses along the anterior vertebral bodies from the 2<sup>nd</sup> cervical down to the sacral base, where it blends into the ligamentous encapsulation of the sacrum.
- Lateral borders of the ALL are attachment sites for the psoas muscle
- Thicker in the lumbar spine than the PLL.
- Can be a pain generator

# Ligaments

## Posterior Longitudinal Ligament

- Extends from the basiocciput to the sacrum.
- Attachments are strongest to the outer layer of the annulus of the IV disk and weakest to the vertebral body where the ligament arches over the opening of the foramen for the central vein.
- Is broad in the neck, narrows when it reaches L1. It takes on a scalloped appearance and is only ½ its original width at L5.
- The scalloped configuration produces a deficiency in the PLL that is located over the posterolateral portion of each lumbar IV disk, to which the posterior portion of the IV disk is also the thinnest portion of the annulus, therefore, is the region of a lumbar disk that is most likely to rupture.

## Iliolumbar Ligament

- Located in the lumbosacral region.
- Attached to the transverse process of L4 and L5 and extends to the iliac crest and anterior and posterior regions of the SI joint.
- Restricts motion at the lumbosacral junction, particularly side bending.
- Clinically it is the first ligament to become tender to palpation when there is LS postural stress.
- A tender point on the iliac crest, located 1 in superior and lateral from the inferior margin of the PSIS
- Its tenderness is a physical clue that should prompt questions about posture and to carefully examine the spine, lower lumbar region and SI joints for somatic dysfunction or acquired short leg.
- The first complaint with irritation to this ligament may be groin pain, causing the patient to think they may have a hernia.

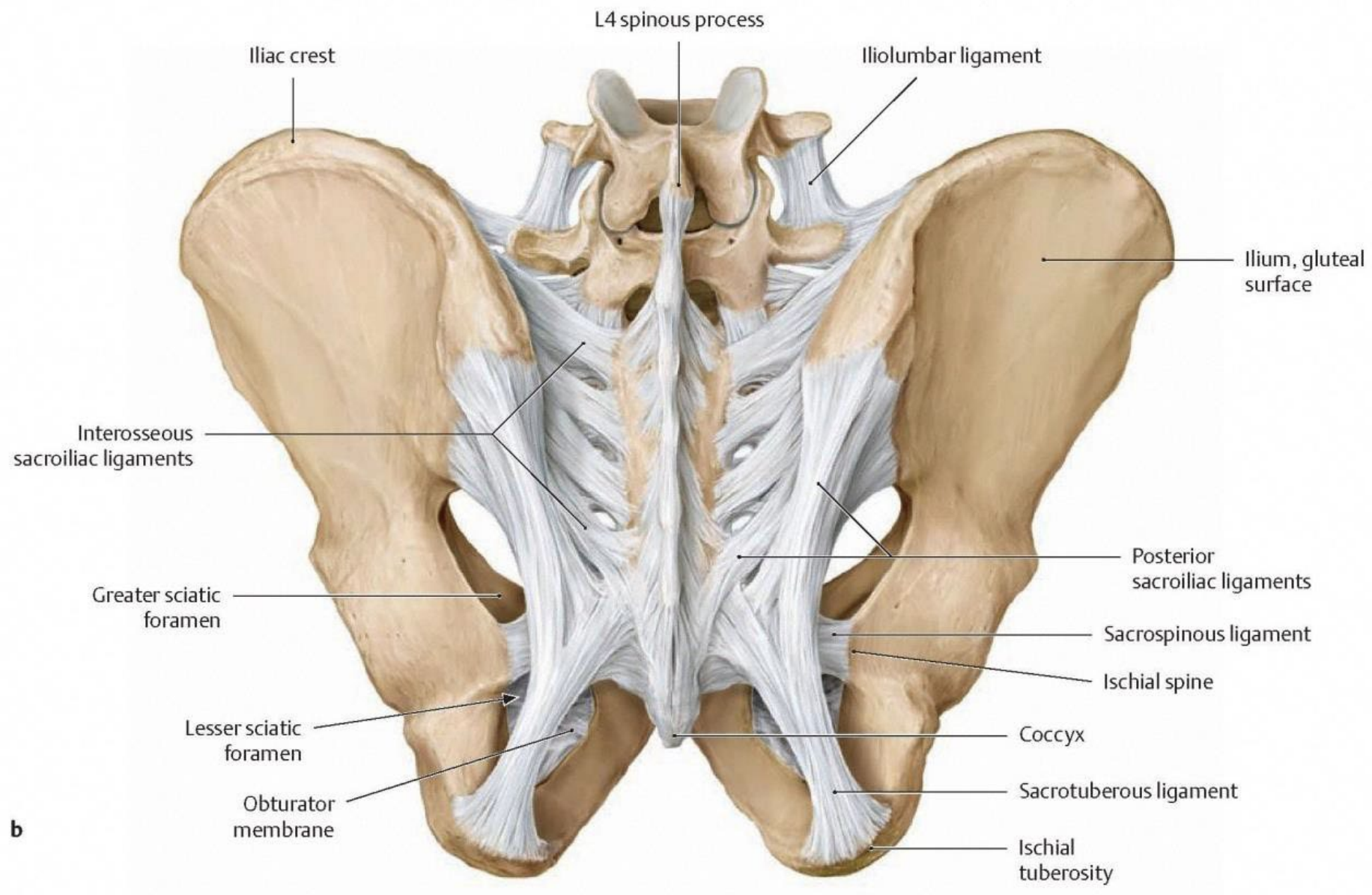

# Nerve Structures

---

- **Spinal Cord**

- Spinal cord terminates at L2 as the conus medullaris (terminal range T12-L2 and some say L3).
- The dural sac terminates by attaching to the spinal canal at S2 level.
- Lumbar spinal canal has a triangular shape configuration and normally decreases in AP dimension as it progresses from L1 to L5.
  - As a person ages, the diameter of the lumbar spinal canal may further be compromised by:
    - Hypertrophy of the PLL; thickening of the ligamentum flava anteriorly, OA, exostoses, osteophytes, tumors, ruptured IV disk.
  - With enough pressure on the canal or the nerves in the cauda equina, there will be loss of reflexes, weakness of muscles, paralysis of the lower extremities, and sphincters of the bladder and rectum (cauda equina syndrome).

# Nerves

---

- **Spinal nerve roots and spinal nerves**

- LS spine gives rise to numerous nerve rootlets from dorsolateral and ventrolateral sulci.
- These nerve roots descend into the vertebral canal, exiting at each IV foramen.
- The roots enter a funnel-shaped lateral recess of the spinal canal that narrows to form the lumbar nerve root canal. The distal end of the root canal is the IV foramen.
  - The walls of the nerve foot are pedicle, ligamentum flavum, and lateral aspect of the IV disk.
- As the nerve root enters the canal it is enveloped by a sheath of spinal dura.
- As the spinal nerves leave the canal, they are attached to the foramen by several fibrous expansions of the canal wall. As the root traverses the canal and foramen it is at risk from several structures
  - Pedicles
  - IV disk
  - Ligamentum flavum
  - Capsule of the facet joint
  - Foraminal ligaments

# Lumbar Plexus

- 
- Composed of T12-L4 nerves and is located next to the lumbar spine behind the psoas major muscle, supply motor and sensory innervation to the lower limb and pelvic girdle.
    - **Iliohypogastric nerve: T12-L1** – supplies motor innervation to the caudal portions of the transverse abdominis and internal oblique muscles of the abdomen. Further divided into the anterior cutaneous branch and the lateral cutaneous branch for sensory of the skin above and to the side of the inguinal ligament
    - **Ilioinguinal nerve: T12-L1** – provides motor innervation to caudal transverse abdominis and internal obliques and sensory branches (femoral branch) to the upper and inner thigh, and the anterior scrotal nerve supplying anterior part of the scrotum or labia majora.
    - **Genitofemoral nerve: L1-2** – femoral branch supplies the skin below the inguinal ligament; genital branch accompanied by the spermatic cord or round ligament of the uterus giving sensory innervation to these areas and for the medial thigh. Motor innervation to the cremaster muscle
    - **Lateral cutaneous nerve of the thigh: L2-L4** – purely sensory supplies the lateral skin of the thigh.
    - **Femoral nerve: L1-L4 – longest nerve of the lumbar plexus.** Just below the inguinal ligament the nerve divides into the sensory anterior femoral cutaneous nerves to supply the skin of the anterior thigh and into the motor branches that supply the iliopsoas, pectineus, sartorius, and quadriceps femoris muscles. The Saphenous nerve is the sensory terminal branch of the femoral nerve that courses along the femoral artery and vein and moves into the adductor canal. Finally, it follows the great saphenous vein to the medial side of the lower leg, thus innervates the skin between the knee and the foot on the medial side
    - **Obturator nerve: :L2-4** – from a motor standpoint it innervates the adductor muscles (adductor longus, brevis, gracilis, pectineus, and adductor magnus muscles), as well as the obturator externus muscle. The anterior branch ends in the sensory cutaneous branch which innervates a palm-sized area at the distal end of the inner thigh.



# Causes of Low Back Pain



# Causes of Low back pain

- 
- May be acute or chronic
  - Acute causes of low back pain may be due to fracture, recent strain, disk herniation, infection (osteomyelitis, meningitis, discitis), referred pain.
  - Chronic causes are much more common
    - Congenital
    - Metabolic
    - Neoplastic
    - Degenerative

# Sprains/Strains

- 
- Microscopic or macroscopic injury to the soft tissue
  - Maybe acute or chronic
  - Strain – soft tissue injury to the muscles/tendons
  - Sprain – ligamentous injury
  - Most lumbar strains are first degree strains. They refer pain into the low back, buttock, and posterior lateral thigh. The patient complains of achiness and muscle spasms. Pain is increased with activity or prolonged sitting/standing
    - May cause somatic dysfunction of lumbar spine with rotation. Any form of OMT is acceptable.
    - In the acute phase soft tissue techniques and indirect techniques seem to be more beneficial. Direct techniques carry a likelihood of exacerbating problems by increasing sympathetic drive.
    - Use of hot and cold packs, NSAIDS, low dose opioids, muscle relaxers maybe be beneficial on a case to case basis - <2 weeks time duration.

# Somatic Dysfunctions of the LS spine (Non-Specific Low Back Pain)

- 
- Location of back pain: low back, buttocks, posterior lateral thigh → localized type of pain
  - Quality: ache, muscle spasm
  - Signs and symptoms: increased pain with activity or prolonged standing/sitting/increased muscle tension
  - TX: OMT – counterstrain, muscle energy, HVLA. Should be directed at decreasing restrictions in other areas that may alter the structure-function relationship of the lumbosacral spine. Look for pelvic/sacral dysfunction; thoracic dysfunction as well.

# Psoas Syndrome

---

- Flexion contracture of the iliopsoas
- Pathogenesis- often precipitated from prolonged positions that shorten the psoas (sports injuries, overuse injury, repetitive jumping). However, organic causes may also cause psoas spasm through viscerosomatic or somatosomatic reflexes. Organic causes must be ruled out before initiating treatment for mechanical causes
- Organic causes: appendicitis, sigmoid colon dysfunction, ureteral calculi, endometriosis, ureter dysfunction, metastatic cancer of prostate, salpingitis
- Location of Pain – low back sometimes radiating to groin
- Quality- ache/muscle spasm
- S/S – restricted hip extension, increased pain when standing or walking, positive Thomas Test, tenderpoint 1 cm medial to ASIS, non-neutral dysfunction of L1 or L2, positive pelvic shift test to the contralateral side, lumbar hyperlordosis, and contralateral piriformis spasm
- Treatment - an acute spasm may benefit from ice to decrease pain and edema. Do not initially use heat. Counterstrain to the anterior iliopsoas tender point or prone psoas muscle energy is very effective followed by muscle energy or HVLA to the lumbar dysfunction. Some believe that symptoms will not resolve until the L1-L2 dysfunction is treated.

# Iliolumbar Ligament Syndrome/Iliac Crest Syndrome

- 
- Pathogenesis – iliolumbar ligament becomes stressed, irritated/inflamed, or torn. Occurs with acute L5 disc protrusion/herniation, spinal instability, or spondylolisthesis, direct trauma, lifting injury, a direct fall in which the ligament is pulled at the iliac crest insertion site.
  - S/S – tissue texture changes at the ilial insertion of the ligament. Pelvic side shift towards the iliolumbar ligaments. Ipsilateral adductor muscle tight
  - TX –rest, ice, analgesics, massage, injections; OMT- counterstrain to iliolumbar ligament has significant clinical value

# Spinal Stenosis

---

- Narrowing of the spinal canal or IV foramina usually due to degenerative changes, causing pressure on the nerve roots (or rarely the cord).
- Pathogenesis – degenerative changes in the lumbar spine include:
  - Hypertrophy of the facet joints or ligamentum flavum
  - Broad based disc bulge, protrusion or herniation
  - Loss of IV disc height
- Location of pain – lower back to legs
- Quality of Pain – ache, shooting pain or parathesias
- S/S – worsened by lumbar extension (standing, walking or lying supine).
- Radiology – osteophytes and decreased IV disc space are usually present. MRI demonstrating central or foraminal stenosis
- TX – OMT should be directed at decreasing any restrictions, improving ROM and releasing any lumbar extensor spasm. Conservative tx – PT, NSAID's, low dose tapering steroids. An epidural steroid injection may be useful if conservative tx is not effective. Surgical laminectomy with decompression indicated if all above fails.

# Degenerative Changes

- 
- **Spondylosis** – radiographic term for degenerative changes within the IV disc and ankylosing of adjacent vertebral bodies.
  - **Spondylolysis** – a defect usually of the pars interarticularis without anterior displacement of the vertebral body. Symptoms and treatment similar to spondylolisthesis. Since lateral lumbar x-rays will not reveal slippage, oblique views will identify the fracture of the pars interarticularis. It is often seen as a “collar” on the neck of the scotty dog.
  - **Spondylolisthesis** – anterior displacement of one vertebra in relation to the one below. Often occurs at L4 or L5. Can be due to bilateral fractures in the pars (usually L5/S1) or can be related to degeneration of the facet joints from longstanding instability (usually L4/5).
    - 5% of the population – half are asx. Patients who become sx do usually after the age of 20
    - Location – low back pain, buttocks and/or posterior thigh
    - Quality – ache
    - S/S – increase pain with extension based activities. Tight hamstrings bilaterally. Stiff-legged, short stride, waddling type of gait. Typically, no neurological deficits. Positive vertebral step off sign (palpating the spinous process there is an obvious anterior displacement at the area of the lysis).
    - Radiology – anterior displacement of one vertebrae on another on lateral films. Can be classified by grades 1-4 based on the degree of slippage.
    - TX- most patients (85-90%) can be managed conservative management. The goals of manipulation is to reduce lumbar lordosis and somatic dysfunction. Can treat a Grade 1 and 2 with omt. HVLA is relatively contraindicated. Can use lateral recumbent soft tissue techniques, MFR, lumbar/sacral release and/or traction techniques. Additional conservative management includes weight loss, avoiding high heels and avoiding flexion based exercises. Heel lifts have been advocated to control postural mechanics. Lumbo-sacral orthotics can be considered for short term stability. Patient with a high grade lysis with neurologic sx or findings will need neurosurgical evaluation for spinal fusion, and either postural or instrumented reduction of the amount of slip.



## Spondylolisthesis

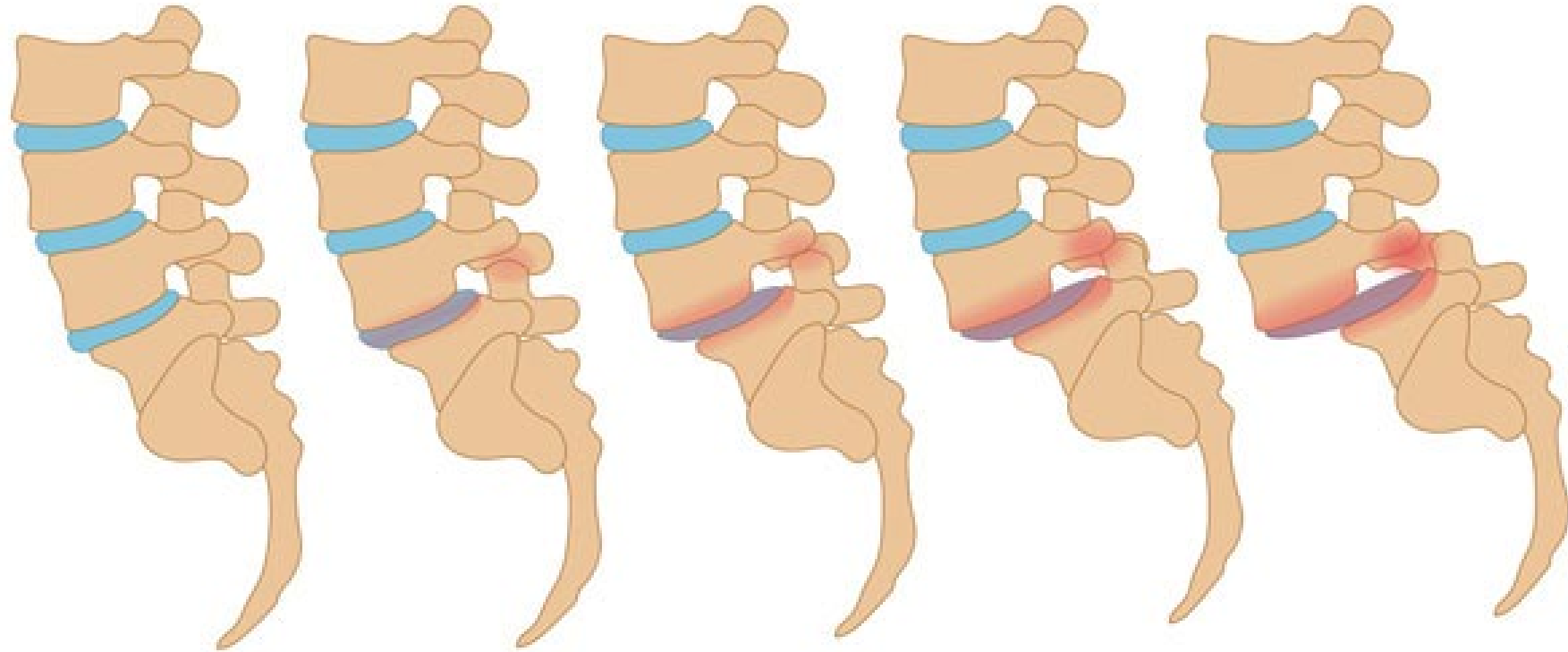

**Normal spine**

**Grade 1 <25%**

**Grade 2: 25-50%**

**Grade 3: 50-75%**

**Grade 4 >75%**

# Cauda Equina Syndrome

---

- Pressure on the nerve roots of the cauda equina usually due to a massive central disc herniation, spondylolisthesis, fracture, or tumor
- Location of pain – low back and legs
- Quality – sharp
- Radiology – MRI is the gold standard
- S/S – saddle anesthesia, decreased deep tendon reflexes, decreased rectal sphincter tone, and loss of bowel and bladder control
- TX – **emergent surgical decompression** of the cauda equina is imperative within 48 hours. If surgery is delayed too long, permanent neurologic damage can ensue. **NO OMT!!!!!!**

# Osteopathic Discussion

---

# Tenets of Osteopathic Medicine

- The body is a unit; the person is a unit of body, mind, and spirit
- The body is capable of self-regulation, self-healing, and health maintenance
- Structure and function are reciprocally interrelated
- Rational treatment is based upon an understanding of the basic principles of body unity, self-regulation, and the interrelationship of structure and function

# Lumbar Mechanics and Somatic Dysfunction

Due to the alignment of the facets (backward and medial to the superior facets), the major motion of the lumbar spine is flexion and extension.

There is a small degree of side bending and very limited amount of rotation

Motion follows Fryette's Laws

Somatic dysfunction may occur in any of the three planes of motion

It is not uncommon to find that a single segment dysfunction does not follow Fryette's Principle, especially L5. In sacral torsions, motion of L5 will influence the motion of the sacrum in 2 ways:

- Side bending of L5 will cause a sacral oblique axis to be engaged on the same side
- Rotation of L5 will cause the sacrum to rotate towards the opposite side

# Somatic Dysfunction

- “Impaired or altered function of related components of the somatic system: skeletal, arthrodial, and myofascial structures, and related vascular, lymphatic, and neural elements.”
- **TART changes**
  - Tenderness → Where does it hurt?
  - Asymmetry → Where is there a change in structure on one side?
  - Range of Motion is altered → Where is there less motion?
  - Tissue texture abnormality → where do the tissue feel tight? Knot-like or swollen?

# Fryette Law's – Law 1

- **Law I** = when the spine is in neutral (easy normal), sidebending and rotation are in opposite directions. (**Type I Mechanics**)

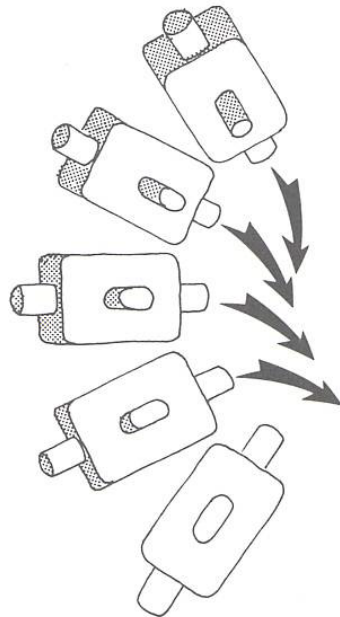

- **Occurs in neutral (facets not engaged)**
- **Found in thoracic and lumbar spines**
- **Forms long curves, multiple segments**
- **Compensatory**

# Type I Mechanics

- Posterior transverse process and paravertebral fullness visible when spine is in neutral
  - Asymmetry not significantly altered by flexion/extension
  - Side bending and rotation opposite directions
- Side bending right
  - Rotation left

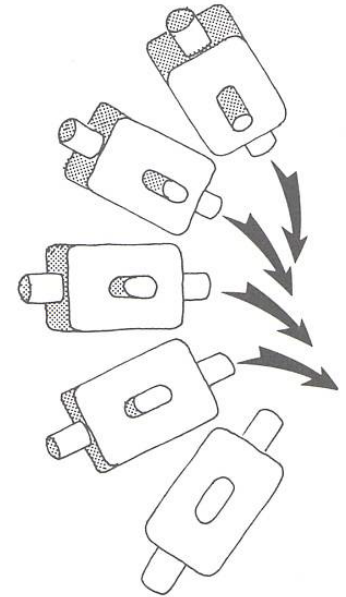



# Fryette's Law II

- ❖ When the spine is flexed or extended (non-neutral), side bending and rotation are in the same directions (Type 2 mechanics)
- ❖ Occurs in flexion and extension
  - ❖ Facets engaged
- ❖ Occurs in thoracic and lumbar spines
- ❖ Usually single segment
- ❖ Found at apices and crossovers and/or site of viscerosomatic reflexes
- ❖ Primary somatic dysfunction
  - ❖ Due to strain or viscerosomatic reflex

# Type 2 Mechanics

## Extension Somatic Dysfunction

- **In flexion** – exaggeration of asymmetry
  - Left facet can open freely
  - Right facet locked closed – cannot open
  - Pivots around right facet
  - Rotates and side bents right
- Restriction =  $FR_L S_L$
- Somatic Dysfunction =  $ER_R S_R$

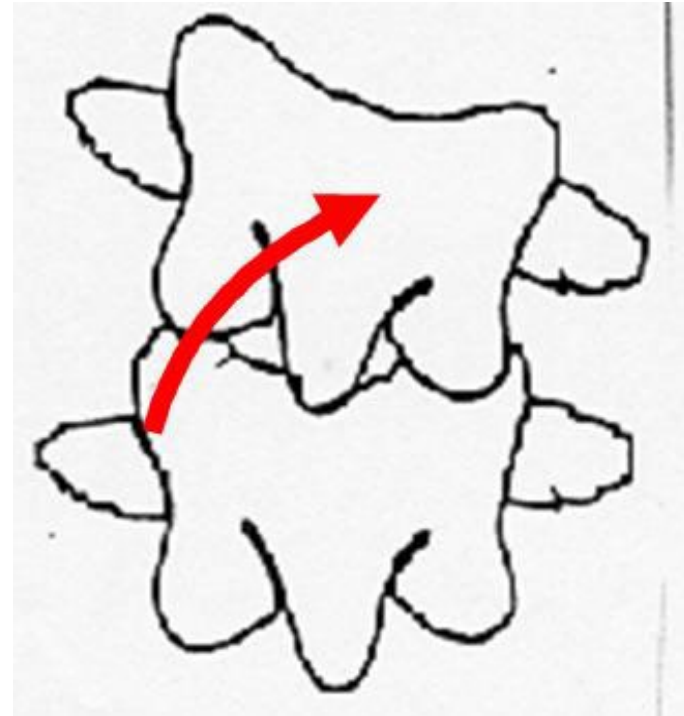

# Type II Mechanics

## Extension Somatic Dysfunction

- **In extension** – no asymmetry as both facets close easily
  - No apparent rotation/side bending asymmetry
  - Most comfortable position for patient
- Restriction =  $FR_L S_L$
- Somatic Dysfunction =  $ER_R S_R$

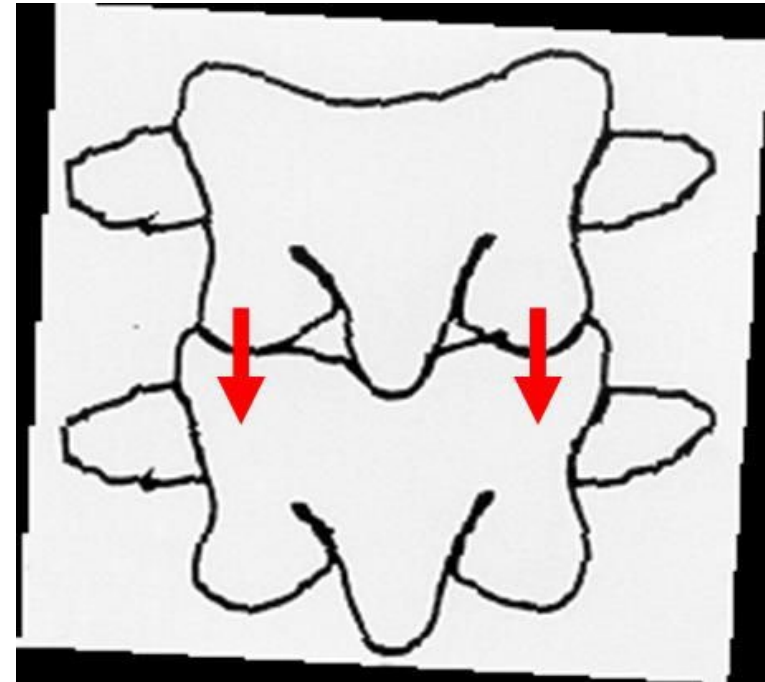

# Type II Mechanics

## Flexion Somatic Dysfunction

- **In extension** – exaggeration of asymmetry
  - Left facet closes normally
  - Right facet locked open – cannot close
  - Causes sidebending and rotation left
- Restriction =  $ER_R S_R$
- Somatic Dysfunction =  $FR_L S_L$

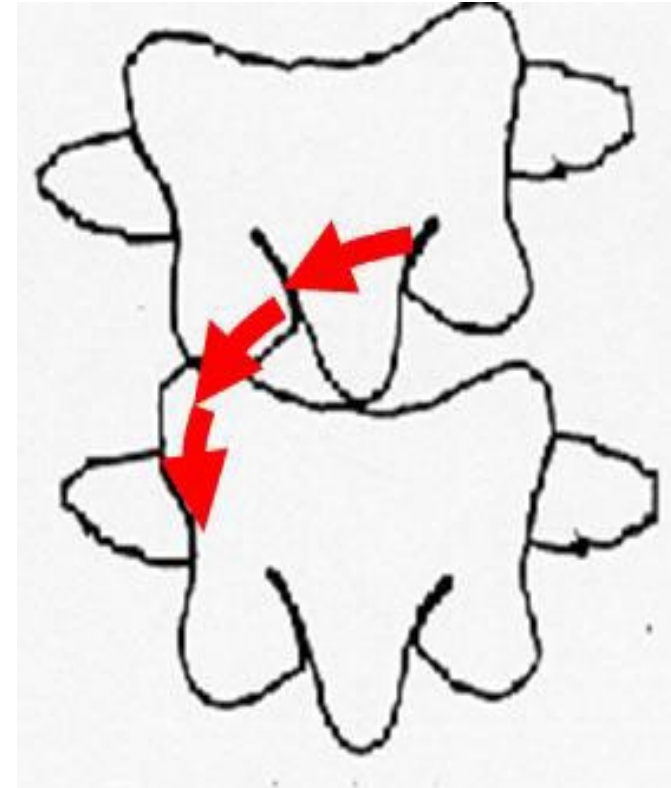

# Type II Mechanics

## Flexion Somatic Dysfunction

- In **Flexion** – no asymmetry as both facets can open easily
  - No apparent rotation/side bending asymmetry
  - Most comfortable position of the patient
  - Restriction =  $ER_R S_R$
  - Somatic Dysfunction -  $FR_L S_L$

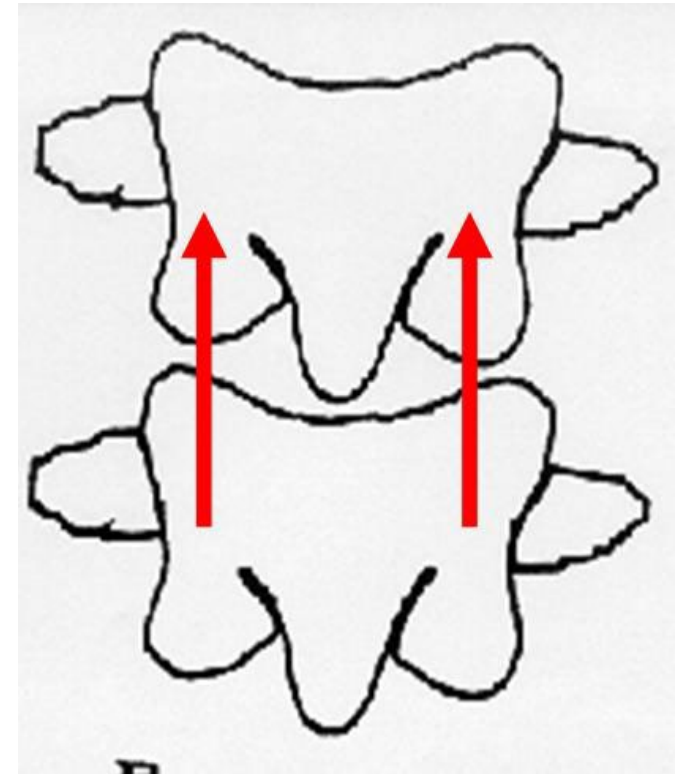

# Memory Aid



• Type 1:

- Sidebending and Rotation opposite directions

• Type 2:

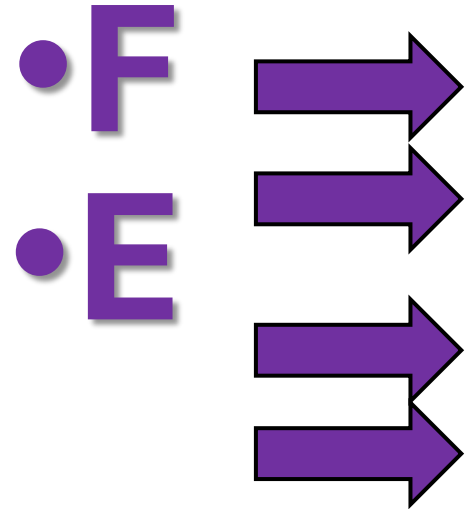

- Sidebending and Rotation same directions

Type I S/D	Type II S/D
Neutral; sidebending and rotation opposite sides	Flexion or extension; sidebending and rotation to same side.
NS(R)R(L) or NS(L)R(R)	FR(R)S(R), ER(R)S(R), FR(L)S(L), or ER(L)S(L)
Facets not engaged	Facets engaged
Multiple segments, long curves	Single segments
Compensatory, adaptive	Traumatic / primary / viscerosomatic
Rotation toward convexity, out from under the load	Rotation towards the concavity, into the load
Smooth curves	Apices and crossovers, viscerosomatic reflexes
Treat last after Type II, if necessary	Treat first



OMT  
Diagnosis and  
Treatment



# Goals of OMT

- Restore maximum pain-free movement of the musculoskeletal system
- To do this:
  - Assess what movement is present
  - Perform a technique to improve motion if there is a dysfunction
  - Reassess to see if there is better movement
- Know your indications and contraindications

# Assessment

- The key in history is ruling out “Red Flag”
- Red Flags = **RIFT**
  - **R**adiculopathy – saddle anesthesia, GU symptoms, severe or progressive neurological deficits of lower extremity, loss of anal tone, weak quads (knee extension weakness), ankle plantar flexors, evertors, dorsiflexors (foot drop).
  - **I**nfection – fever, chills, risk factors (immunosuppression, IV drug use)
  - **F**racture – trauma, fall, lifting
  - **T**umor – patient <20 or >50 years old; history of cancer, constitutional symptoms, pain worse in supine/night.
- Prior to OMT:
  - Neurological Screen → motor, sensory, deep tendon reflexes for both upper and lower extremities.
- Osteopathic Structural Exam
  - TART

# Choice of Treatment Modality

- Direct vs Indirect Techniques
  - **Direct** - “engages” the restrictive barrier (we move the tissue we treat into the restrictive barrier).
    - HVLA, muscle energy, direct MFR, soft tissue (can be direct or indirect), lymphatic pumps, BLT (can be both)
  - **Indirect** – treatment moves the tissue away from the restrictive barrier
    - Counterstrain, FPR, indirect MFR, certain soft tissue, BLT
- The more acute the injury, we should use an indirect technique or very gentle direct techniques. As more time passes from injury, we can use more direct techniques
- The older the patient, the more likely we should use indirect techniques
- Avoid HVLA when fracture could be suspected, or when we could cause a fracture (osteoporotic patients).
- Lumbar strains/sprains – treat the lumbar spine first, then treat the psoas, since the psoas is the most often the problem, and is often the most acute part of the problem.
  - Treat the L1-L2 as noted prior first.

**Lumbar Rotation Testing—Prone**

1. With the patient prone or seated, place your thumbs on a lumbar vertebra's transverse processes located an inch lateral to the spinous process;
2. Push anteriorly on the right transverse process to induce rotation left; Push anteriorly on the left transverse process to induce rotation right;
3. Restricted rotation left = rotated right; Restricted rotation right = rotation left.



Testing L4 rotation left



Neutral, sidebending left, rotation right (Drawing by William A. Kuchera, DO, FAAO)

**Lumbar Rotation Testing—Seated**

1. With the patient seated or prone, palpate the lumbar paraspinal area, comparing right and left sides for increased fullness;
2. Fullness may be due to muscle tension, edema, or vertebral rotation to that side;
3. Vertebral rotation multiple segments = neutral or type 1 somatic dysfunction with sidebending to opposite side;
4. Vertebral rotation single segment = nonneutral or type 2 somatic dysfunction with sidebending to same side—test flexion and extension;
5. Rotation worse in flexion = extension somatic dysfunction; rotation worse in extension = flexion somatic dysfunction.

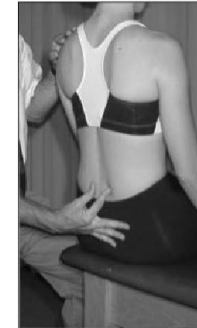

Palpation for L3 rotation



Flexion testing



Extension testing

# Soft Tissue

## Treatment

### **THORACOLUMBAR KNEADING/STRETCHING**

**INDICATIONS:** Thoracic or lumbar paraspinal muscle tension associated with back pain, chest wall pain, and other problems.

**RELATIVE CONTRAINDICATIONS:** Acute lumbar strain and sprain, acute vertebral or rib fracture.

**TECHNIQUE** (prone):

1. Stand on the opposite side and place your cephalad palm on the tense muscle lateral to the spinous processes;
2. Grasp the ASIS on the side of tension with your caudad hand;
3. Slowly knead the tension by leaning into your cephalad hand with the arm straightened to push the muscle anteriorly and laterally, avoiding sliding over the skin;
4. Simultaneously stretch the tense muscle by slowly pulling your caudad hand posteriorly to lift the ASIS until resistance is felt;
5. Repeat simultaneous kneading and stretching until tension is reduced.

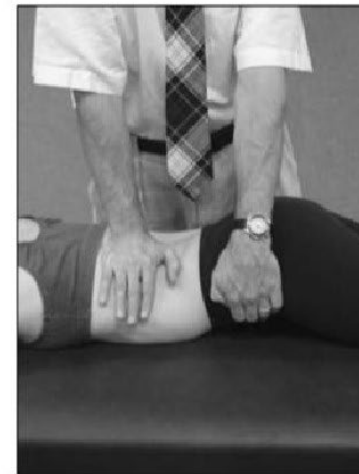

**Thoracolumbar kneading/stretching**

# Counterstrain – Anterior and Posterior points

## PALPATION

### Lumbar Tender Points

1. Palpate for posterior lumbar tender points at the following locations:
  - a) **Posterior T10–L5**—spinous processes or 1/2–1" lateral;
  - b) **Posterior L3**—gluteal musculature halfway between posterior L4 and L5;
  - c) **Posterior L4**—iliac crest in posterior axillary line;
  - d) **Posterior L5 (upper pole L5)**—superior surface of posterior superior iliac spine (PSIS) at insertion of iliolumbar ligament;
  - e) **Lower pole L5**—inferior surface of the PSIS.
2. Palpate for anterior lumbar tender points at the following locations:
  - a) **Anterior T9**—1/2–1" superior to umbilicus;
  - b) **Anterior T10**—1" below umbilicus;
  - c) **Anterior T11**—2" below umbilicus;
  - d) **Anterior T12**—inner aspect of iliac crest in mid-axillary line (not visible in photo);
  - e) **Anterior L1**—1/2" medial to anterior superior iliac spine (ASIS);
  - f) **Anterior L2**—medial surface of anterior inferior iliac spine (AIIS);
  - g) **Anterior L3**—lateral surface of AIIS;
  - h) **Anterior L4**—inferior surface of AIIS;
  - i) **Anterior L5**—pubic ramus 1/2" lateral to pubic symphysis.



Posterior lumbar palpation  
(LPL5 shown)



Anterior lumbar tender points  
(ASIS palpation shown,  
AT12 not shown)

# Counter Strain Techniques – Posterior

Lumbar Diagnosis and Treatment • 119

## LOWER POLE L5 COUNTERSTRAIN

**INDICATIONS:** Lower pole L5 tender point associated with back pain, pelvic pain, hip pain, and other problems.

**RELATIVE CONTRAINDICATIONS:** Acute fracture, hip dislocation, and severe hip osteoarthritis.

**TECHNIQUE** (prone):

1. Locate the tender point on the inferior aspect of the posterior superior iliac spine, labeling it 10/10;
2. Flex the hip and knee 90° and retest for tenderness;
3. Fine tune this position with slight hip adduction until tenderness is minimized to 0/10 if possible but at most 3/10;
4. Hold the position of maximum relief for 90 seconds, maintaining finger contact to monitor for tissue texture changes but reducing pressure;
5. Slowly and passively return the leg to the table and retest for tenderness with the same pressure as initial labeling.



Lower pole L5 tender point and treatment position

118 • Chapter 6

## T10–L5 POSTERIOR COUNTERSTRAIN

**INDICATIONS:** Posterior T10–L5 tender point associated with back pain, pelvis pain, chest pain, and other problems.

**RELATIVE CONTRAINDICATIONS:** Acute fracture, hip dislocation, severe hip osteoarthritis.

**TECHNIQUE** (prone):

1. Locate the tender point, labeling it 10/10;
2. Stand on the opposite side and lift the thigh on the side of the tender point to extend the hip;
3. Retest for tenderness;
4. Fine tune this position with slightly more hip extension, abduction, or adduction until tenderness is minimized to 0/10 if possible but at most 3/10;
5. Hold the position of maximum relief for 90 seconds, maintaining finger contact to monitor for tissue texture changes but reducing pressure;
6. Slowly and passively return the hip to neutral and retest for tenderness with the same pressure as initial labeling. If successful, consider prescribing LUMBAR POSITION OF EASE.



L3 posterior tender point and treatment position

# Counterstrain – Anterior

## **T9–L5 ANTERIOR COUNTERSTRAIN**

**INDICATIONS:** Anterior T9–L5 tender point associated with back pain, pelvic pain, chest wall pain, abdominal pain, and other problems.

**RELATIVE CONTRAINDICATIONS:** Acute lumbar fracture, acute lumbar strain and sprain.

**TECHNIQUE** (supine):

1. Stand beside the patient and locate the tender point, labeling it 10/10;
2. Passively flex the knees and hips 90° and retest for tenderness;
3. Fine tune this position with increased hip flexion and slight rotation or sidebending of the knees until tenderness is minimized to 0/10 if possible but at most 3/10;
4. Hold the position of maximum relief for 90 seconds, maintaining finger contact to monitor for tissue texture changes but reducing pressure;
5. Slowly and passively return the legs to the table and retest for tenderness with the same pressure as initial labeling.



**Anterior T10 tender point and treatment position**



# Psoas OMT and Stretching

Pelvic Diagnosis and Treatment • 71

## ILIOPSOAS COUNTERSTRAIN

**INDICATIONS:** Iliacus or psoas tender point associated with abdominal pain, pelvic pain, back pain, and other problems (see ILIOPSOAS MUSCLE, p. 72).

**RELATIVE CONTRAINDICATIONS:** Acute lumbar or hip fracture, or hip dislocation.

**TECHNIQUE** (supine):

1. Stand beside the patient and locate the tender point 1" medial and slightly inferior to the ASIS, labeling it 10/10;
2. Cross the ankles and passively flex the knees and hips 90°, allowing the hips to externally rotate;
3. Retest for tenderness and fine-tune this position with increased hip flexion until tenderness is 0/10 if possible, but at most to 3/10;
4. Hold the position of maximum relief for 90 seconds, maintaining finger contact to monitor for tissue texture changes but reducing pressure;
5. Slowly and passively return the legs to the table and retest for tenderness with the same pressure as initial labeling; if successful, consider prescribing ILIOPSOAS POSITION OF EASE and/or ILIOPSOAS STRETCH.



**Psoas tender point and counterstrain position**

Pelvic Diagnosis and Treatment • 73

## ILIOPSOAS POSITION OF EASE

1. Lie on your back with legs propped up on a chair or stool;
2. Cross your ankles with the foot on the side of the back or pelvic pain on top;
3. Let your knees fall apart;
4. If comfortable, take a few deep breaths and rest in this position for 2–5 minutes;
5. Slowly uncross your legs, bring them down, and roll to one side before getting up;  
Use this position 2–4 times a day, or as needed for pain relief.



**Iliopsoas position of ease**

## ILIOPSOAS STRETCH<sup>1</sup>

1. Kneel with one foot on the floor a few feet in front of the other knee;
2. Slowly lean forward onto the leg in front while using your hand to push the other hip forward;
3. Take a few deep breaths and stretch for 10–20 seconds;
4. Repeat to the opposite side;
5. Do this stretch 1–4 times a day.



**Left iliopsoas stretch**

# Lumbar Spine Muscle Energy

128 • Chapter 6

## LUMBAR MUSCLE ENERGY—LATERAL

**INDICATIONS:** Restricted multisegment lumbar rotation associated with back pain, scoliosis, and other problems.

**RELATIVE CONTRAINDICATIONS:** Acute lumbar sprain, undiagnosed radiculopathy, acute vertebral fracture, and vertebral cancer or infection.

**TECHNIQUE:**

1. Stand in front of the patient who is lying with the vertebral rotation side up;
2. Flex the hips until you feel motion in the middle of the restricted segments;
3. Lift both ankles until you feel sidebending in the middle of the restricted segments;
4. Ask the patient to push the ankles down toward the table for 3–5 seconds against your equal resistance;
5. Allow full relaxation and then slowly lift the ankles to a new lumbar sidebending restrictive barrier;
6. Repeat this isometric contraction and stretch 3–5 times or until lumbar mobility returns;
7. Retest lumbar rotation. If successful, consider prescribing LUMBAR EXTENSOR STRETCH.



Muscle energy for L1–5 N R left S right

Lumbar Diagnosis and Treatment • 129

## LUMBAR MUSCLE ENERGY—LATERAL RECUMBENT

**INDICATIONS:** Restricted lumbar rotation associated with back pain, scoliosis, and other problems.

**RELATIVE CONTRAINDICATIONS:** Acute lumbar sprain, undiagnosed radiculopathy, acute vertebral fracture, and vertebral cancer or infection.

**TECHNIQUE:**

1. Stand in front of the patient who is lying with the side of lumbar rotation toward the table;
2. Flex the upward hip until you feel motion at the restricted segment and tuck the foot behind the other knee;
3. Rotate the back toward the table by pushing the upward shoulder posteriorly and lifting the table-side arm and shoulder until you feel rotation at the restricted segment;
4. Place your forearm across the buttock, lean over top of that arm, and use your other arm to stabilize the patient's shoulder, taking care not to push into the ribs or breast;
5. Ask the patient to push the pelvis backward for 3–5 seconds against your equal resistance;
6. Allow full relaxation and then slowly move the pelvis anteromedially to a new lumbar rotation restrictive barrier;
7. Repeat 3–5 times or until lumbar mobility returns;
8. Retest lumbar rotation. If successful, consider prescribing LUMBAR EXTENSOR STRETCH.



Muscle energy for L3 rotated right

# Lumbar Spine HLVA

Lumbar Diagnosis and Treatment • 133

## LUMBAR THRUST—LATERAL RECUMBENT (LUMBAR ROLL)

**INDICATIONS:** Restricted lumbar rotation associated with back pain, scoliosis, and other problems.

**RELATIVE CONTRAINDICATIONS:** Acute lumbar sprain, lumbar joint hypermobility, undiagnosed radiculopathy, acute vertebral fracture, acute herniated or ruptured disc, and vertebral cancer or infection.

**TECHNIQUE:**

1. Stand in front of the patient who is lying on the side of lumbar rotation;
2. Flex the upward hip until you feel motion at the restricted segment and then tuck the patient's foot behind the other knee;
3. Rotate the back toward the table by lifting the table-side arm until you feel rotation at the restricted segment;
4. Use your cephalad arm to stabilize the shoulder, place your other forearm across the buttock, and lean over top of that arm;
5. Ask the patient to take a deep breath and during exhalation slowly push the pelvis anteromedially to take up the rotational slack;
6. At the end of exhalation apply a short quick thrust with your arm and body onto the pelvis in an anteromedial direction;
7. Retest lumbar rotation. If successful, consider prescribing LUMBAR SELF-MOBILIZATION or THORACOLUMBAR STRETCH/SELF-MOBILIZATION.



Lateral recumbent thrust for L3 rotated right

Lumbar Diagnosis and Treatment • 131

## THORACOLUMBAR MUSCLE ENERGY/THRUST—SEATED

**INDICATIONS:** Restricted lumbar or thoracic rotation associated with back pain, scoliosis, and other problems.

**RELATIVE CONTRAINDICATIONS:** Acute lumbar sprain, joint hypermobility, undiagnosed radiculopathy, acute vertebral fracture, and vertebral cancer or infection.

**TECHNIQUE:**

1. Standing behind the seated patient, place your thenar eminence on the posterior transverse process(es);
2. Reach across the upper chest with your other hand and arm to control the patient's shoulders and trunk;
3. Move the trunk into the rotation, sidebending, and flexion-extension restrictive barriers until you feel movement at the restricted segment(s);
4. Ask the patient to straighten the trunk and/or shoulders for 3–5 seconds against your equal resistance;
5. Allow full relaxation and then slowly move the trunk to new restrictive barriers as you push anterior into the posterior transverse process(es);
6. Repeat this isometric contraction and stretch 3–5 times or until lumbar mobility returns;
7. Add a thrust if needed by a short and quick anterior push into the posterior transverse process(es) as you simultaneously move the trunk into its restrictive barriers;
8. Retest lumbar rotation. If successful, consider prescribing LUMBAR SELF-MOBILIZATION or THORACOLUMBAR STRETCH/SELF-MOBILIZATION.



ME for L1–5 N R right S left

# OMT Billing

- Make sure on your note on the physical exam you document your somatic dysfunction/restriction diagnosis under your osteopathic structural exam
  - L2-L5 N Rr Sl
  - L2 Posterior Tenderpoint
- On assessment – you need a pain diagnosis and the somatic dysfunction together (need both for proper billing) for each region (if there are other areas of treatment than you need to do the same for all areas that you treated).
  - Lumbar strain/chronic lumbar back pain
  - Lumbar Somatic Dysfunction
- On your plan – document what technique(s) that you did, along with resolution/improvement/non-improvement of symptoms and improvement/resolution/non-improvement of somatic dysfunction (proves that you rechecked your work after the treatment). It is ok that you document if a particular technique isn't effective and that you choose another technique.
- Billing – along with a .25 modifier
  - 98925 – 1-2 Regions
  - 98926 – 3-4 Regions
  - 98927 - 5-6 Regions
  - 98928 - 7-8 Regions
  - 98929 - 9-10 Regions

# References

- Beatty, D; Steele, K; et al. The Pocket Manual of OMT, Osteopathic Manipulative Treatment for Physicians. 2011.
- Crow, T. Osteopathic Manipulative Medicine Review for Boards. 3<sup>rd</sup> Edition. 2016.
- DiGiovanna, E; et al. An Osteopathic Approach to Diagnosis and Treatment. 4<sup>th</sup> Edition. 2021.
- Netter, F. Atlas of Human Anatomy. 3<sup>rd</sup> Edition. 2004
- Rowane, M; Evans, P. Basic Musculoskeletal Manipulation Skills, The 15 Minute Office Encounter. 2<sup>nd</sup> Edition. 2019
- Savareese, R; Capobianco, J; Cox, J. OMT Review. 3<sup>rd</sup> Edition. 2003.
- Seffinger, M; Kuchera, W. Foundations of Osteopathic Medicine. 4<sup>th</sup> Edition. 2018.

# Intro to POCUS with Basic Lung Ultrasound

FM Refresher Course

James Liszewski, MD

Erin Meier, DO

Diana Davidek, MD

Sarah Sinno, MD



*just a bunch of*  
**HOCUS**  
**POCUS**

# Introduction

- UPMC Horizon Family Medicine Residency faculty and residents
- Jim Liszewski MD - faculty
- Erin Meier DO - faculty
- Sara Sinno MD – 3rd year FM resident
- Diana Davidek MD – 3rd year FM resident
- Ultrasound models: Caitlin, Isabella, Lydia, Noah

(no financial disclosures)



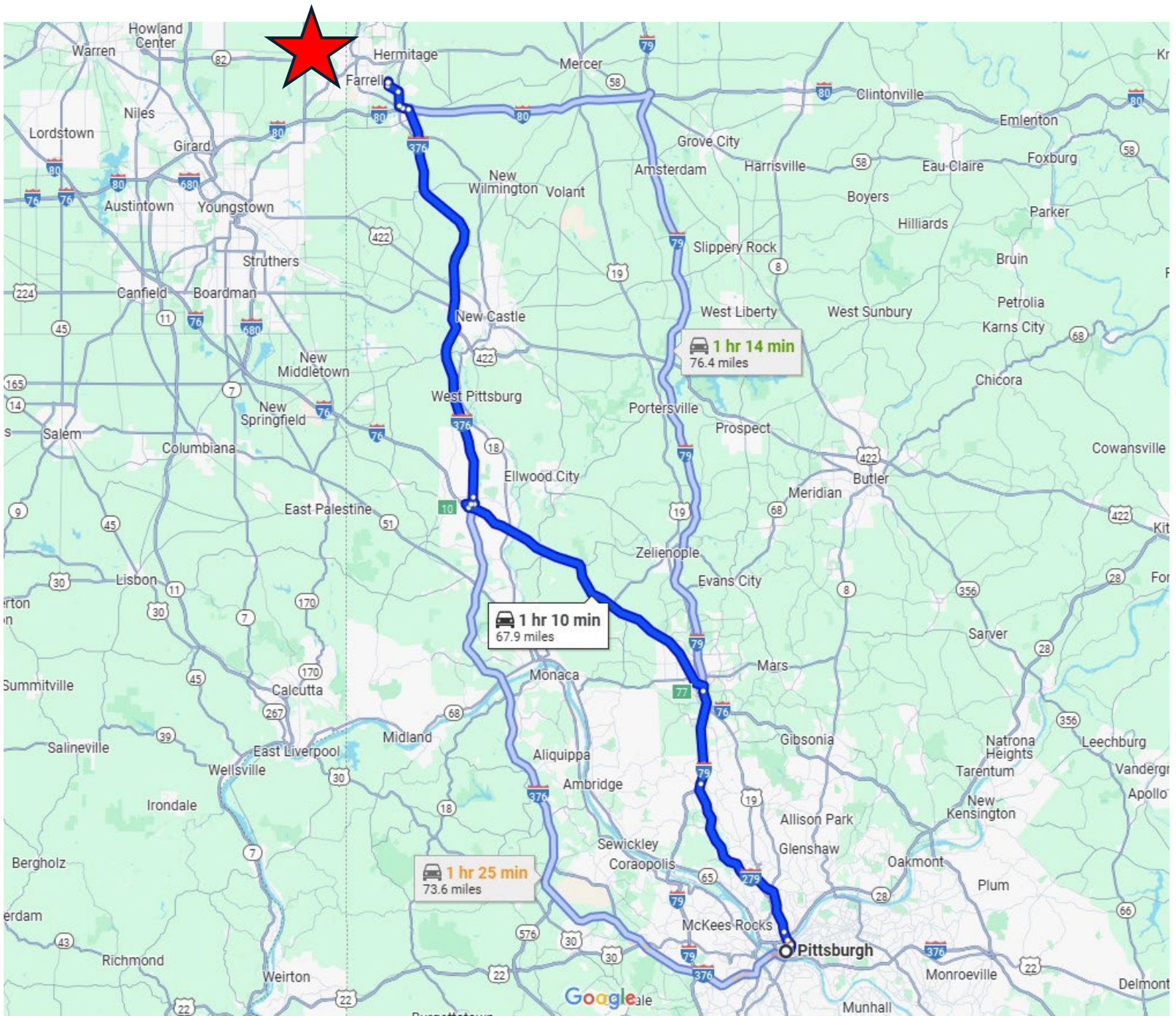

# Objectives

- Understand basic operation of a portable ultrasound device
- Understand the benefits of performing lung ultrasound
- Learn how to perform ultrasound exams of normal lung and pleura

# What is POCUS?

- Ultrasound technology developed initially for military purposes; submarines used to locate other vessels
- First medical ultrasound devices developed in 1940's were large and immobile
- As technology improved, allowed bedside exams (laptop size)
- Initial use was in obstetrics and emergency medicine
- Smaller and more affordable handheld devices since 2000s have led further growth and use

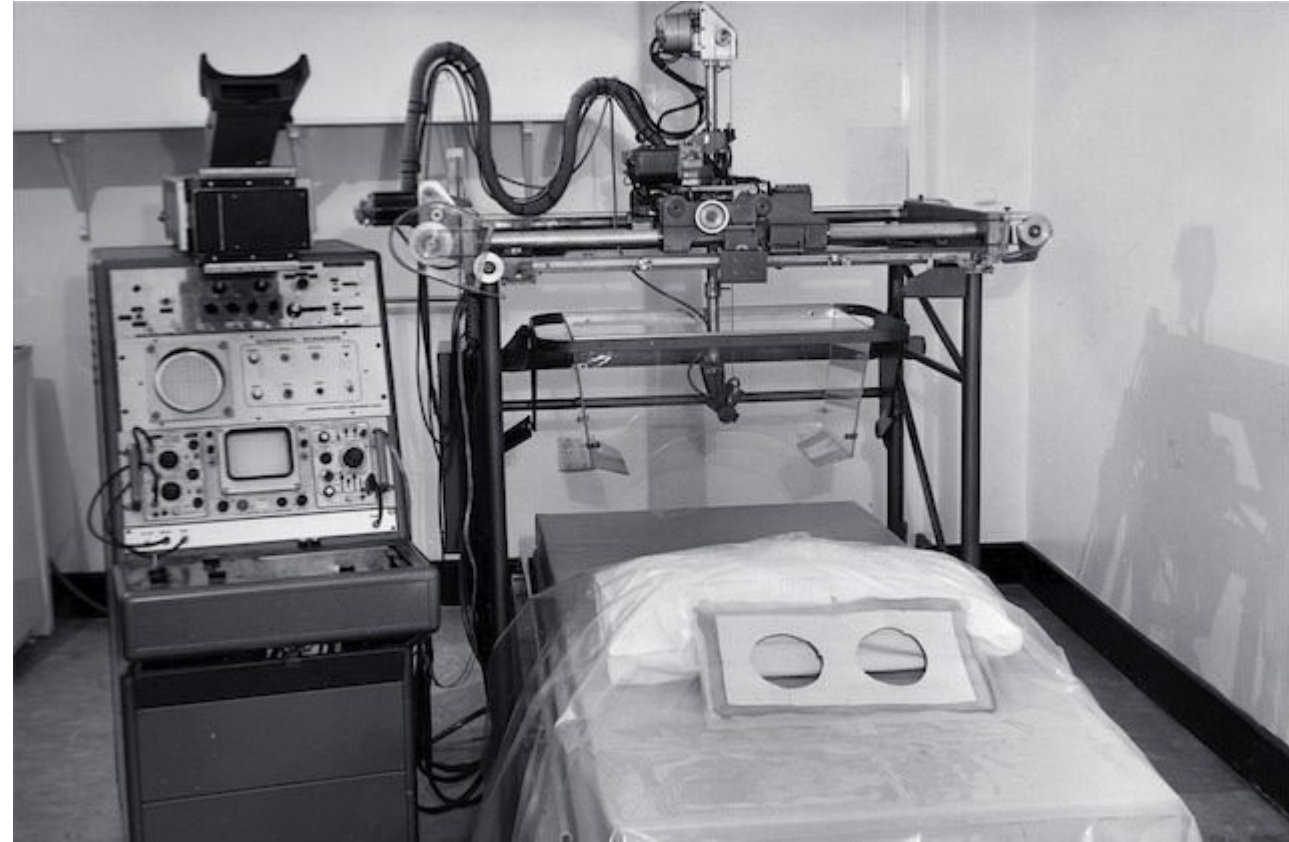

# What is POCUS?

## **DIAGNOSTIC ULTRASOUND**

- High-end device
- Formal complete exam
- Performed by a trained sonographer
- Read by board certified radiologist
- Takes days/weeks to schedule and to obtain results

## **POCUS**

- Less costly device
- Bedside or handheld
- Performed and interpreted by the treating and examining physician
- Immediate results at bedside
- Intended to answer a specific clinical question

# POCUS - Physics

- US is high frequency sound wave
- Electricity powers transducer (crystal)
- Sound wave from crystal travels until hits object
- US waves reflected back to transducer
- Crystal detects US signal
- CPU/processor produces image

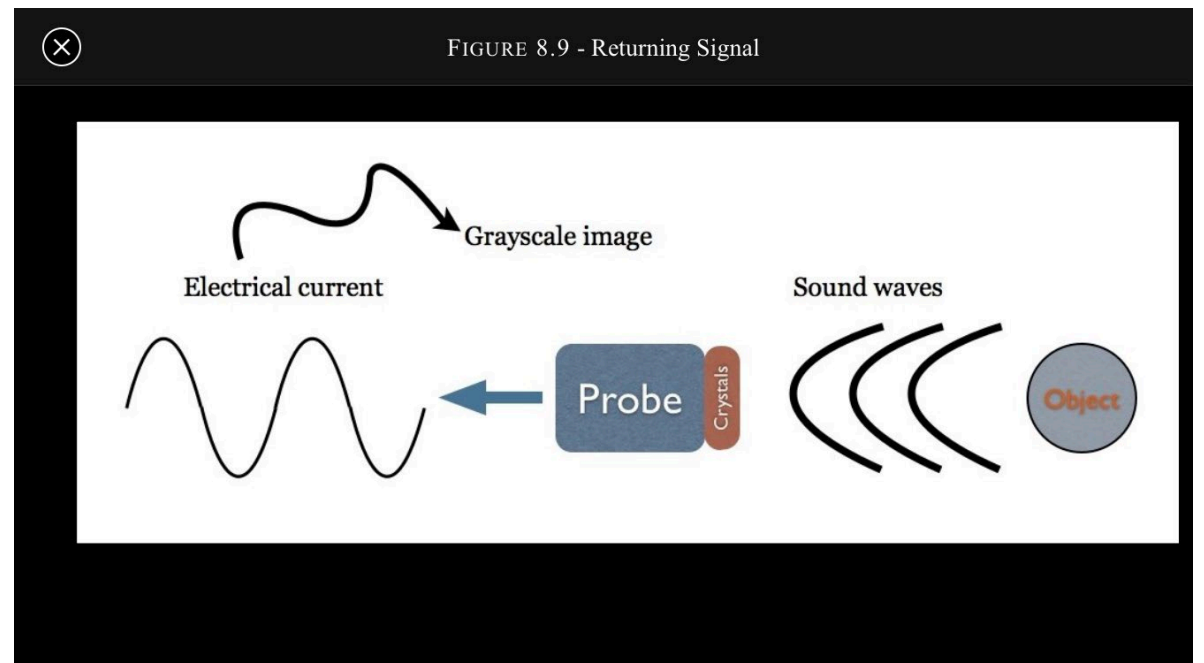
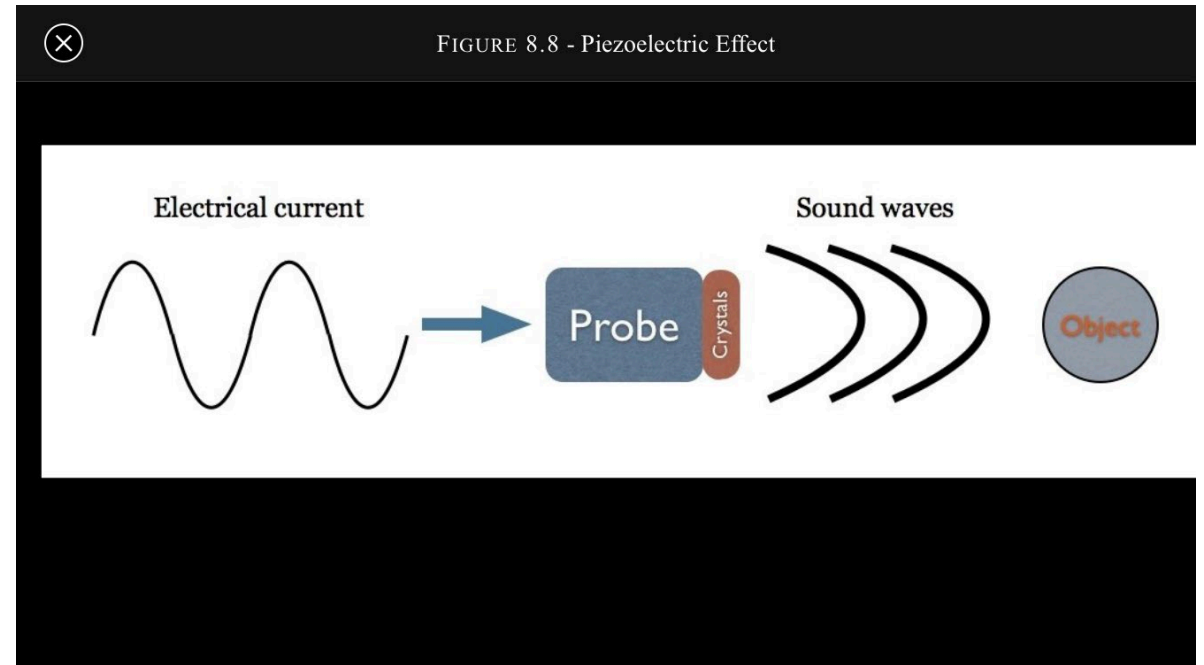

# POCUS - Physics

- How US wave interacts with objects, determines what we see
- Several things can happen:
  - Absorbed
  - Reflected
  - Scattered
  - Refracted

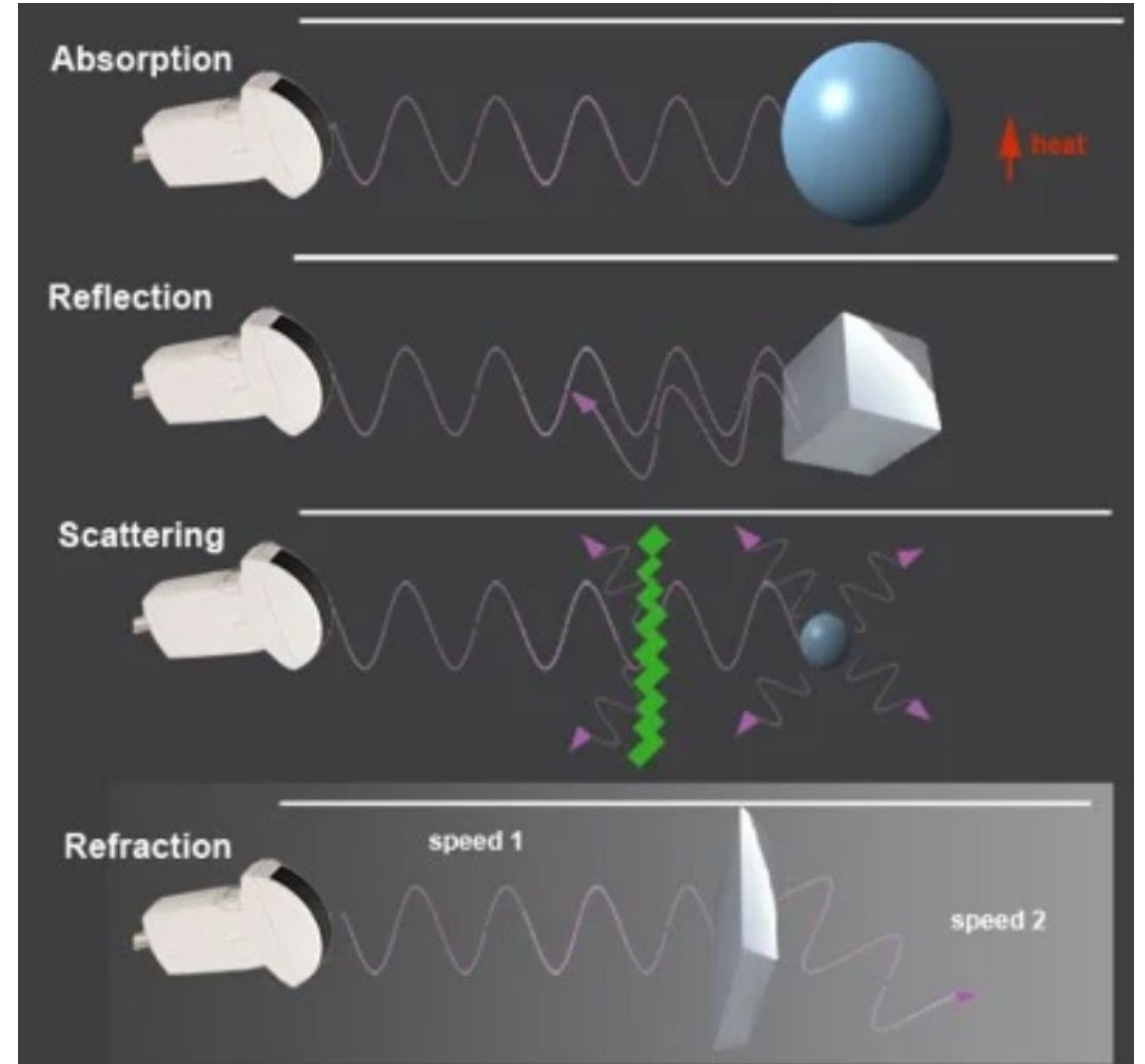

# POCUS - Modes

- B-mode scan: grayscale
- M-mode: tracing of tissue movement over time (cardiac)
- Color Doppler: measures direction of flow

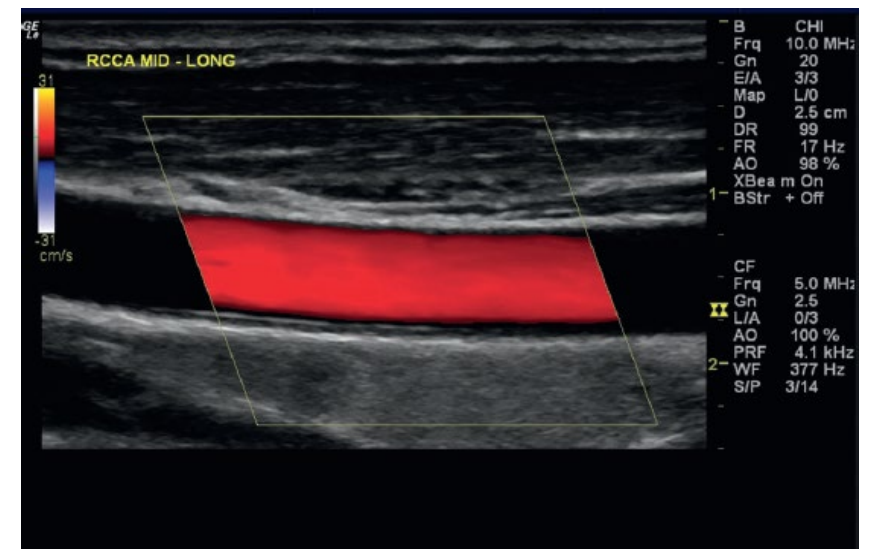
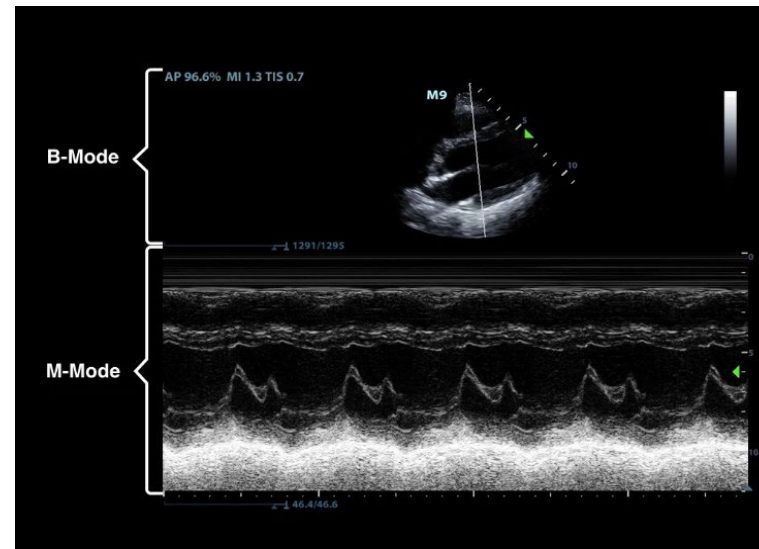
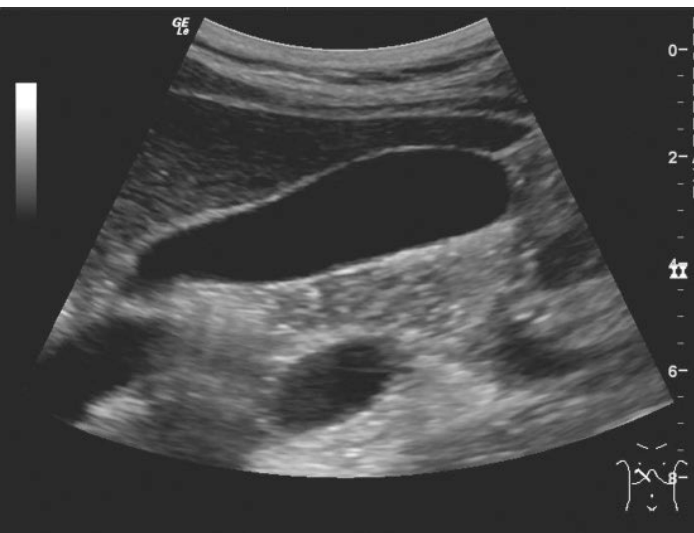

# POCUS – US terms

- Power: energy delivered (fixed)
- Frequency:
  - Number of waves per sec
  - Higher freq = superficial structures
  - Lower freq = deeper structures
- Gain: degree of amplification of return signal
- Depth: adjust to structure

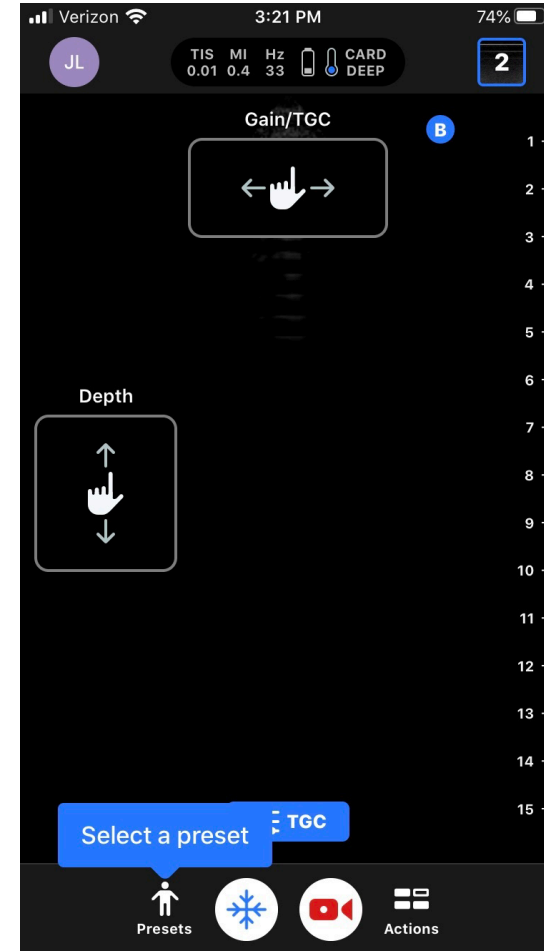



# POCUS – US terms

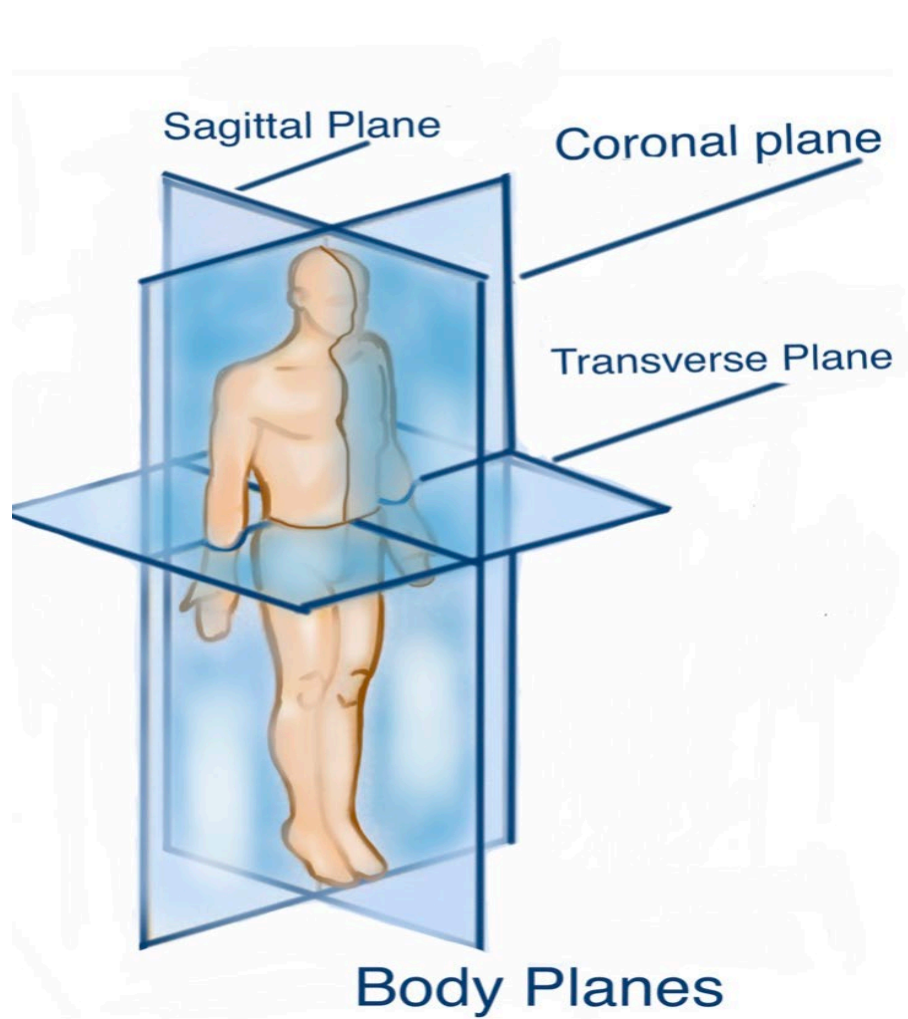

- Sagittal: cephalad to caudal view, or “**long axis**” in frontal plane
- Coronal: **long axis** view in lateral plane
- Transverse/axial: cross section, or “**short axis**”

# POCUS – US terms

## ULTRASOUND IMAGE TERMINOLOGY

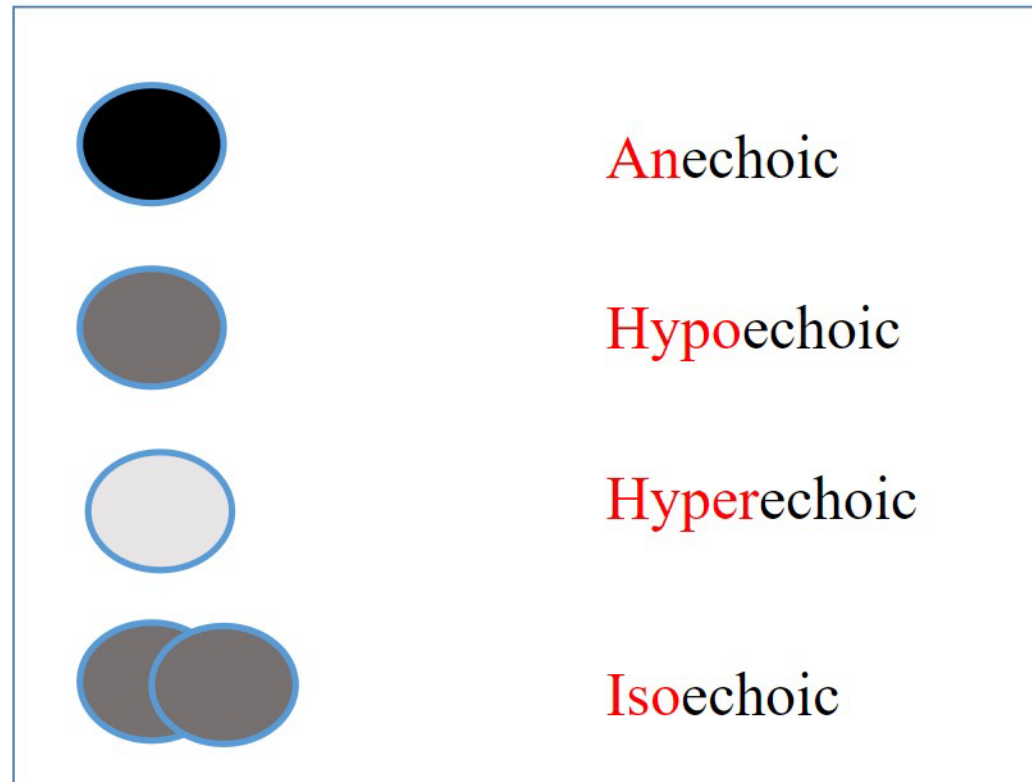

# POCUS – Transducers

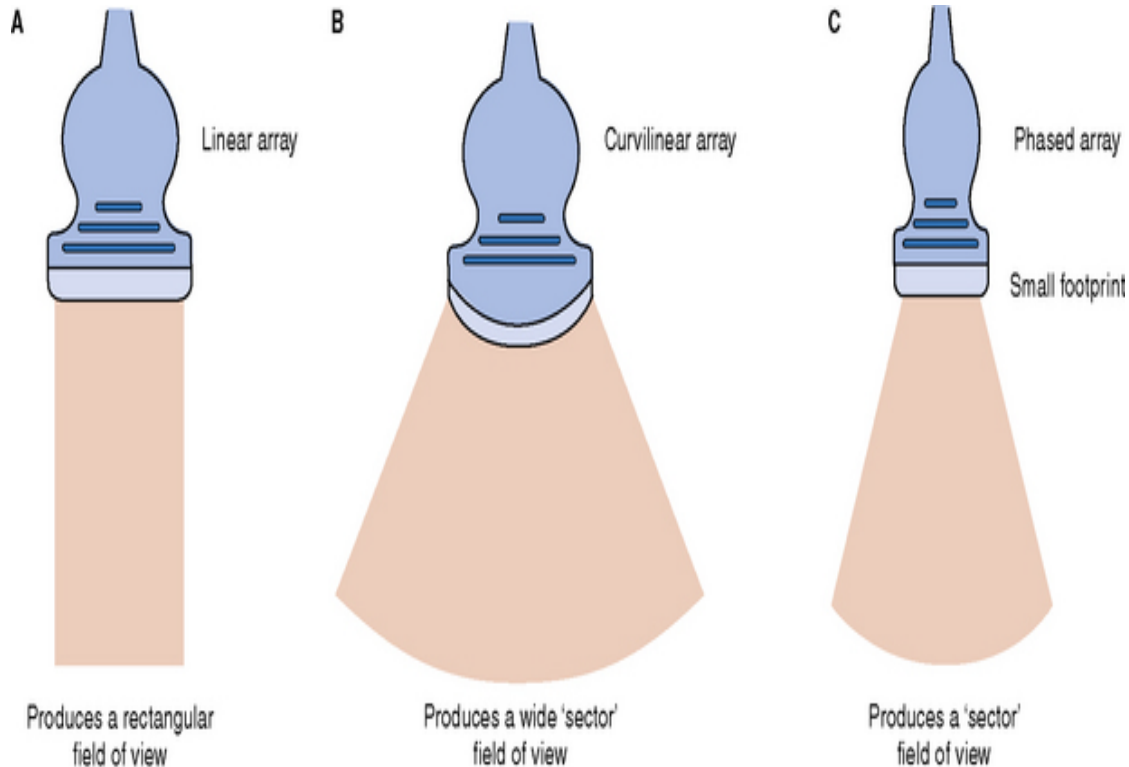

- Linear array:
  - high frequency, better resolution but less penetration
  - Superficial structures
- Curved array:
  - low frequency, deeper penetration but lower resolution
  - Deep structures
- Phased array:
  - Low frequency, small footprint
  - Cardiac and lung.

# POCUS – tissue appearance

## Bone/calcium

- Does not transmit US wave
- Hyperechoic
- Shadowing

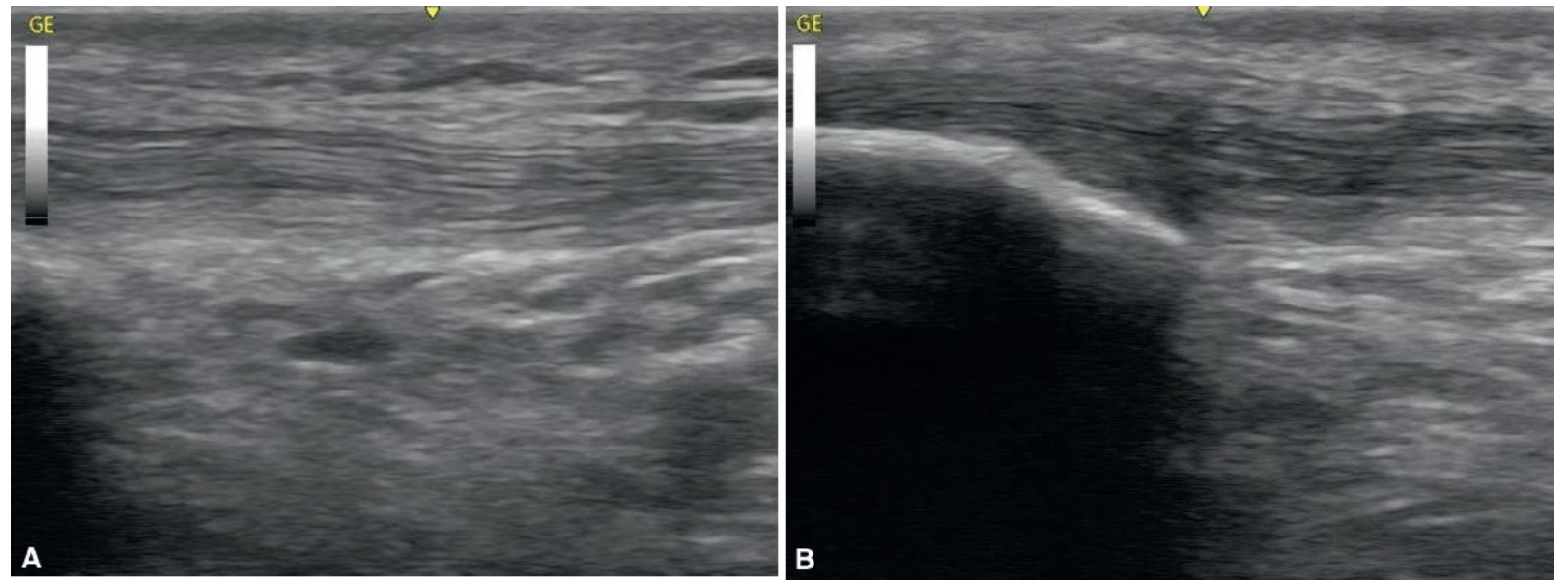

# POCUS – Tissue appearance

## Fluid

- Transmits but does not reflect
- Hypoechoic
- Appears dark

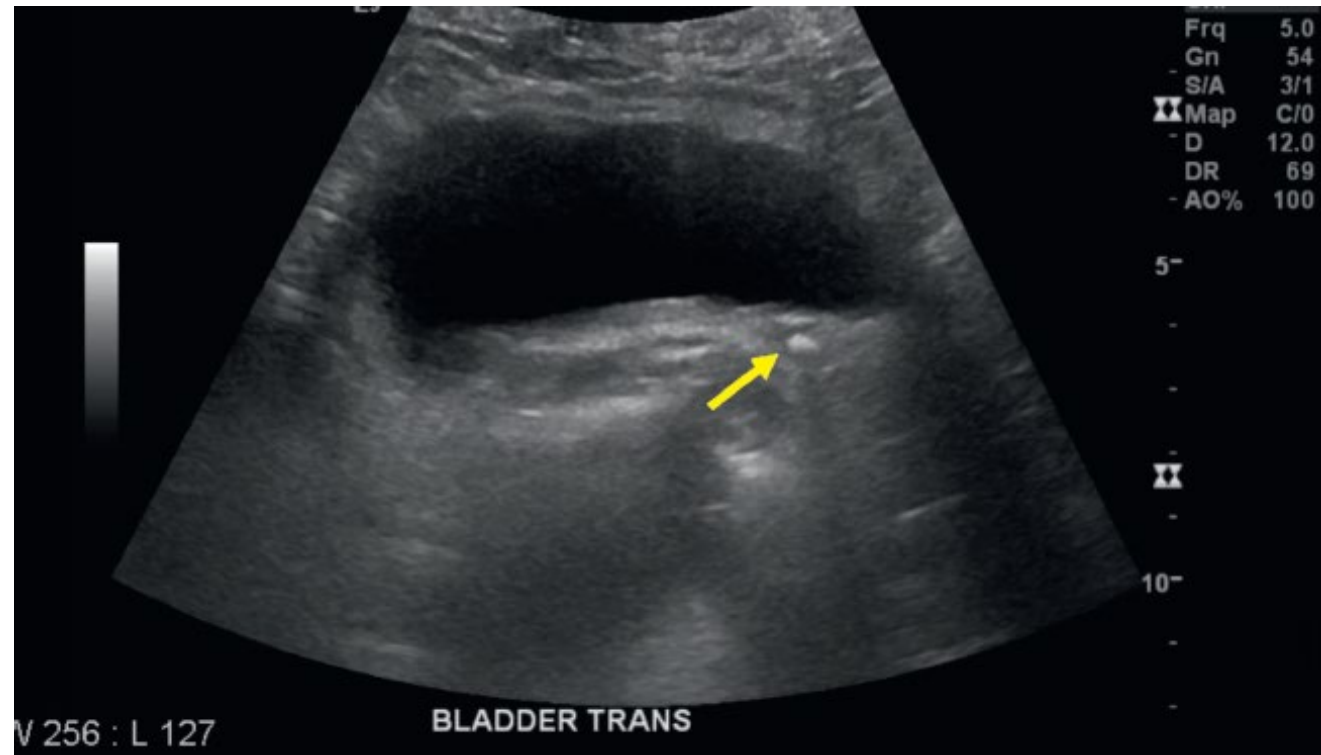

# POCUS – Tissue appearance

## Acoustic window

- Used to see deeper structures
- Example: liver, bladder

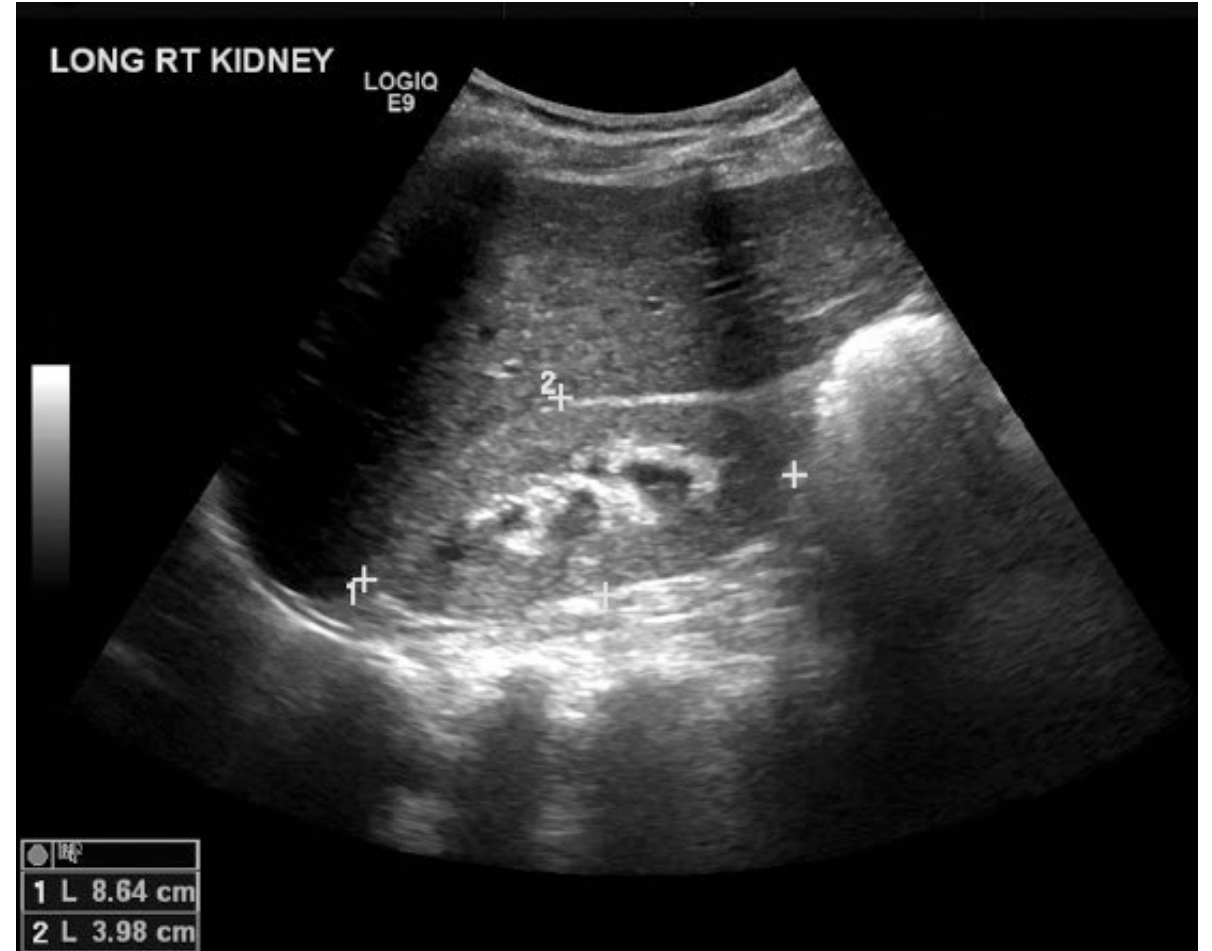

# POCUS – Tissue appearance

## Gas

- Does not transmit or reflect
- Obscures/scatters signal image
- Try to avoid

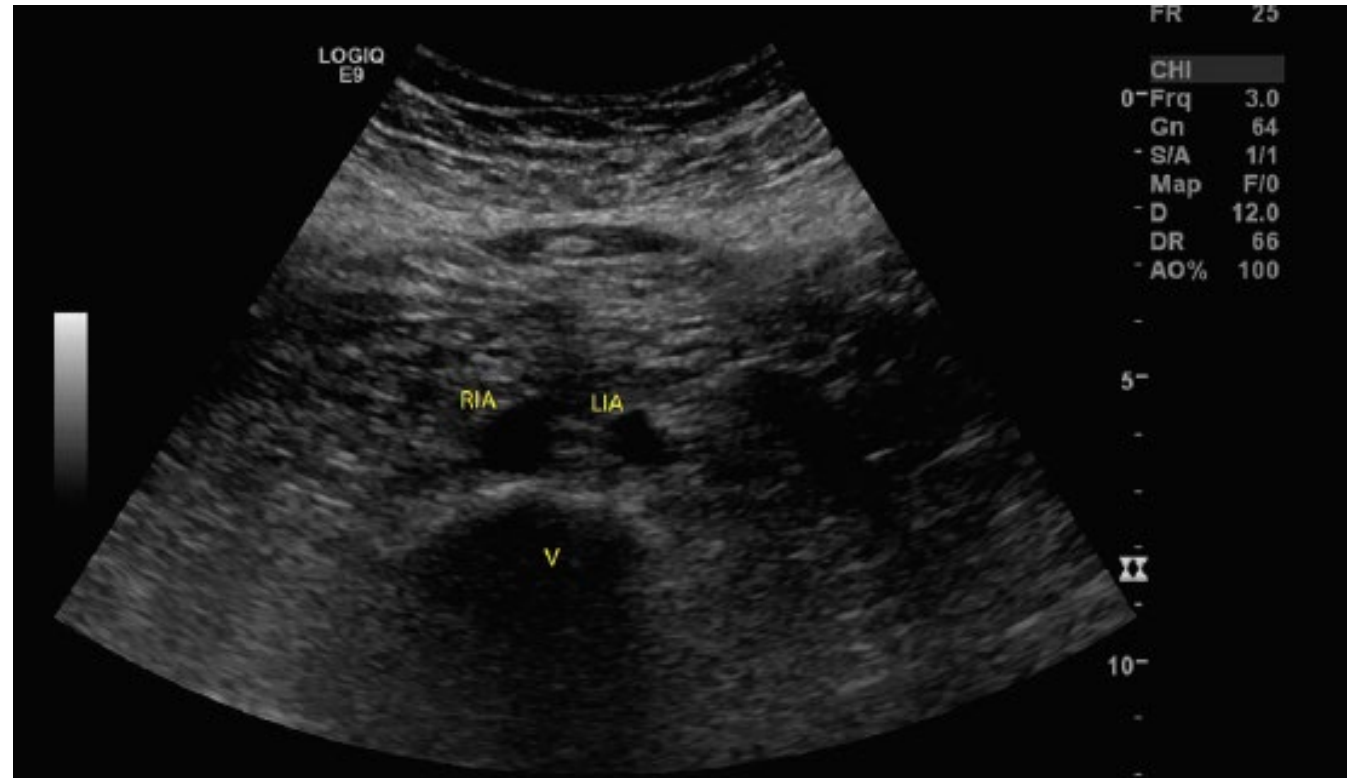

# Handheld Ultrasound

- "Handheld" ultrasound come in many shapes/sizes
- Most utilize cellular phone or tablet to display images
- Butterfly IQ: upfront cost \$2700-\$3900, plus annual cloud fee (\$300-\$400)
- Other devices: GE Vscan, Clarius, EXO iris



# Lung Ultrasound



# Lung Ultrasound

## What is lung ultrasound?

- Uniquely used in point-of-care ultrasound
- Method of detecting interstitial edema
- Used for pleural effusion exam
- Added to standard diagnostic evaluation

## Why learn lung ultrasound?

- Immediate accessibility
- Ability to follow clinical response
- Superior than lung auscultation and chest xray
- Increases the probability and timing of making correct diagnosis

# Lung Ultrasound

- The only ultrasound exam which is purely a POCUS exam
- Initially developed and utilized in critical care settings
- Applies to both inpatient, outpatient, and pediatrics settings
- IDEAL primary care POCUS exam
- Straightforward, easy to learn
- Sensitivity/specificity 88%-100% in detecting fluid overload, pneumonia, pneumothorax, and asthma/COPD

# Lung Ultrasound vs Auscultation

**Table 3**

Interobserver variability.

Lung Ultrasound	
A-pattern	$\kappa = 0.71$ (95% CI: 0.70–0.74)
Pathological B-lines	$\kappa = 0.73$ (95% CI: 0.73–0.75)
Focal B-lines	$\kappa = 0.73$ (95% CI: 0.72–0.75)
Diffuse B-lines	$\kappa = 0.81$ (95% CI: 0.81–0.83)
Consolidation	$\kappa = 0.94$ (95% CI: 0.93–0.95)
Pleural effusion	$\kappa = 0.89$ (95% CI: 0.88–0.90)
Lung Auscultation	
Wheezes	$\kappa = 0.63$ (95% CI: 0.61–0.65)
Fine crackles	$\kappa = 0.68$ (95% CI: 0.66–0.70)
Coarse crackles	$\kappa = 0.18$ (95% CI: 0.16–0.20)
Rhonchi	$\kappa = 0.38$ (95% CI: 0.36–0.40)
Normal	$\kappa = 0.29$ (95% CI: 0.27–0.31)



# MAKING SENSE OF ARTIFACTS

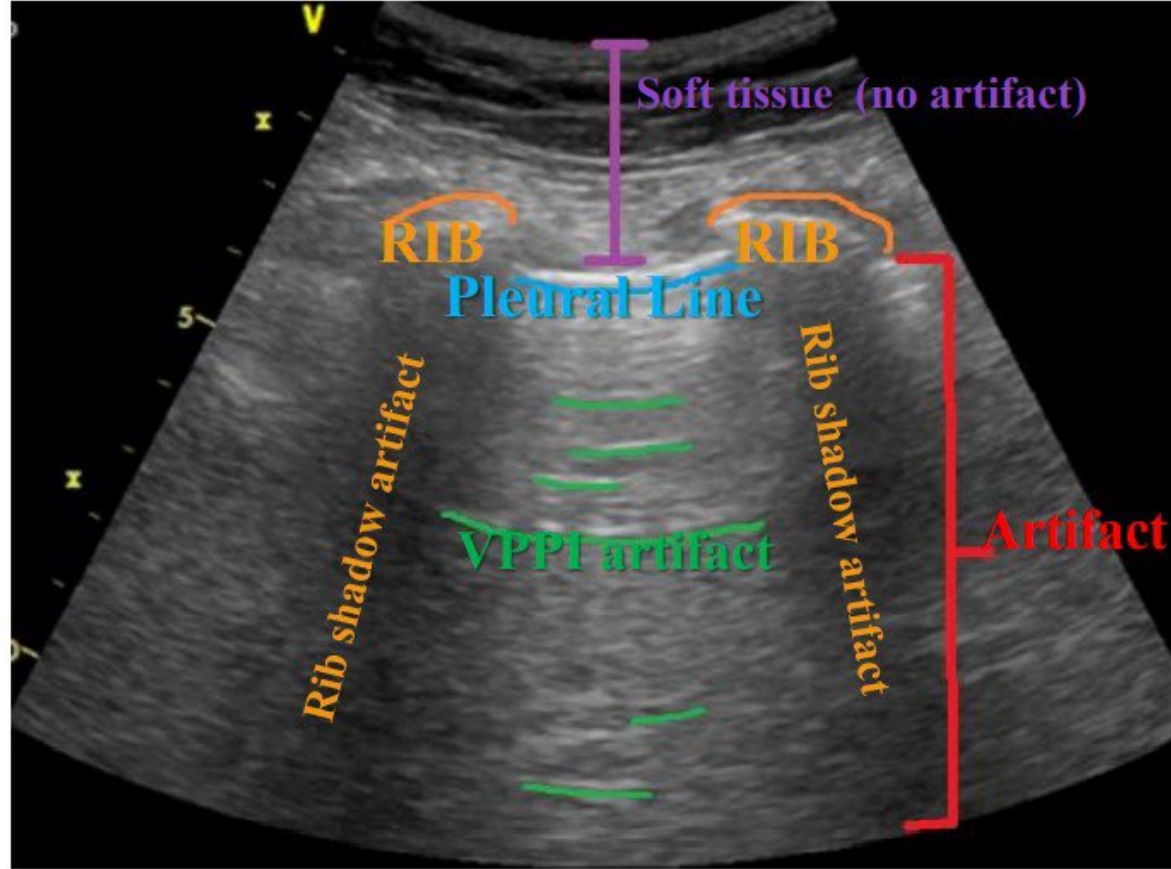
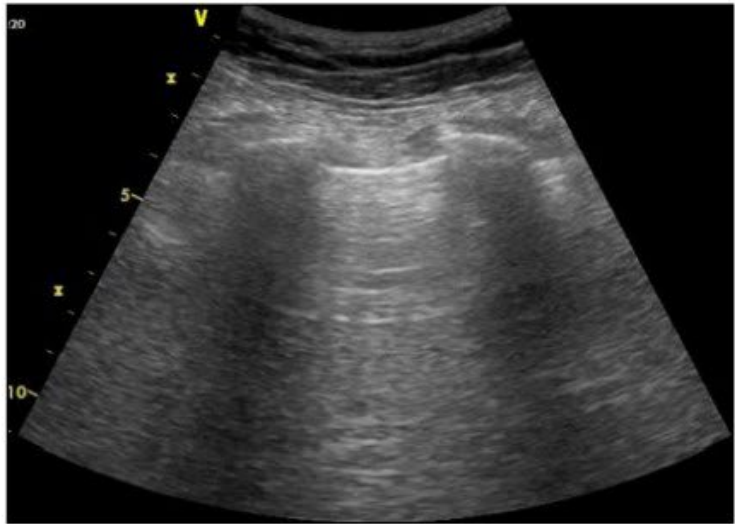

Goal is to distinguish *Abnormal* artifacts from the normal ones...

Copyright 2021 UofSC SOM

# Lung Ultrasound - location

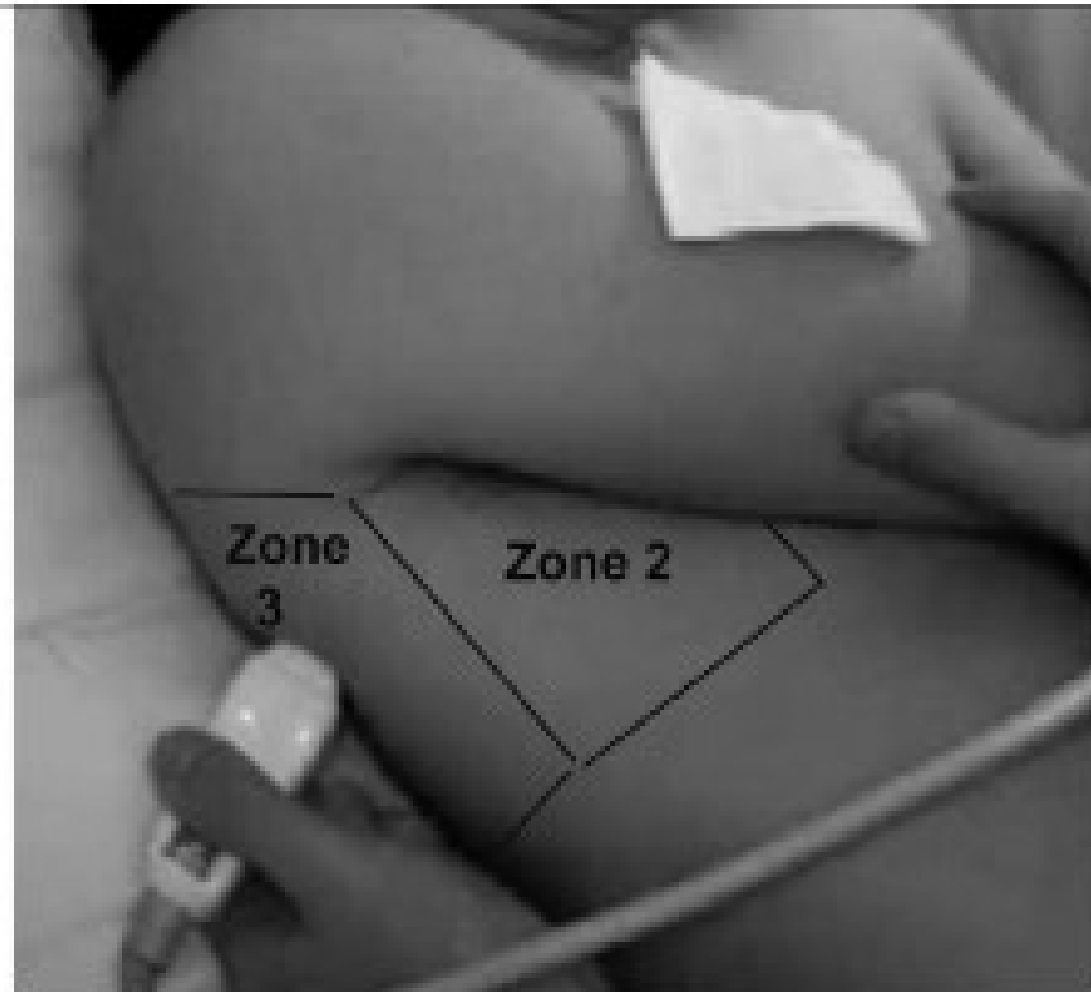
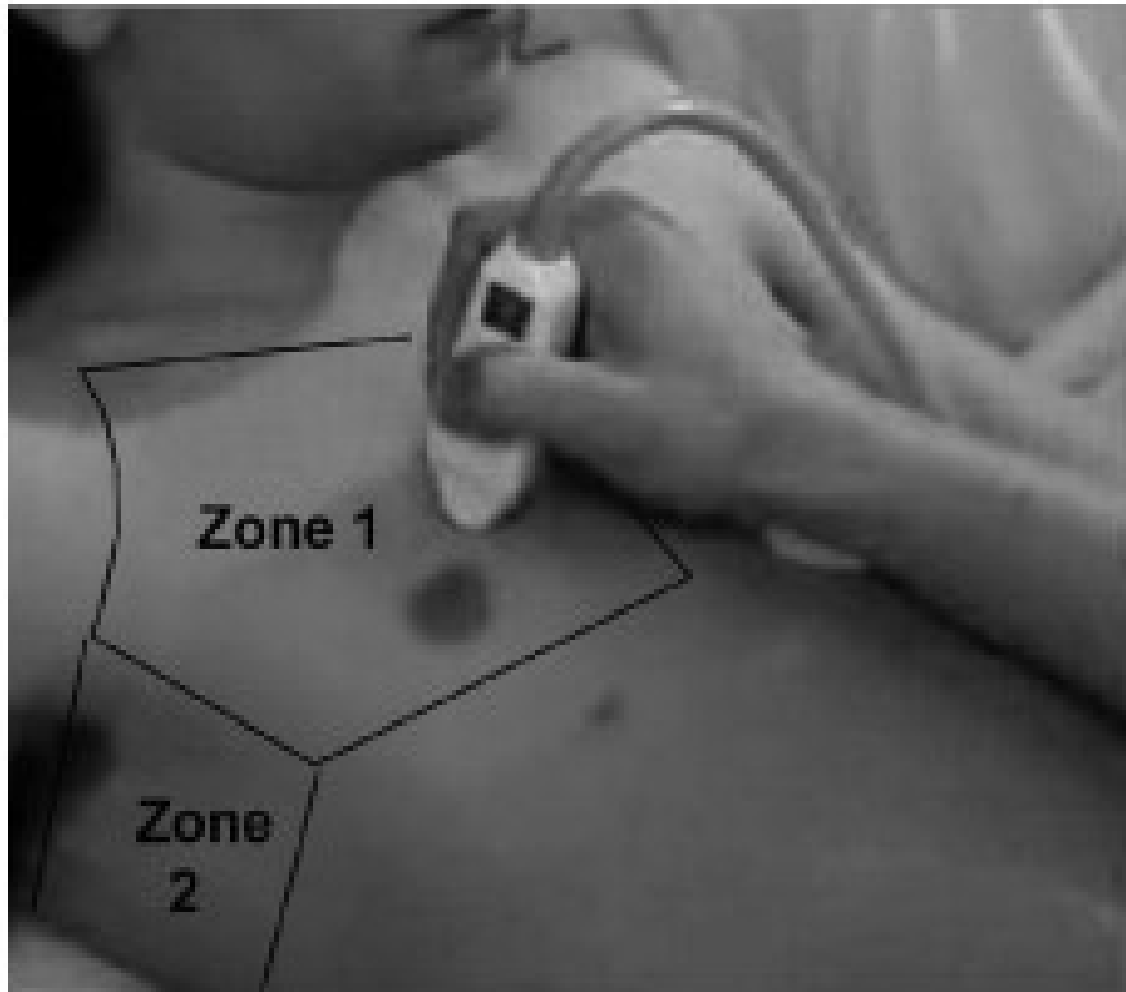

# Lung Ultrasound - Location

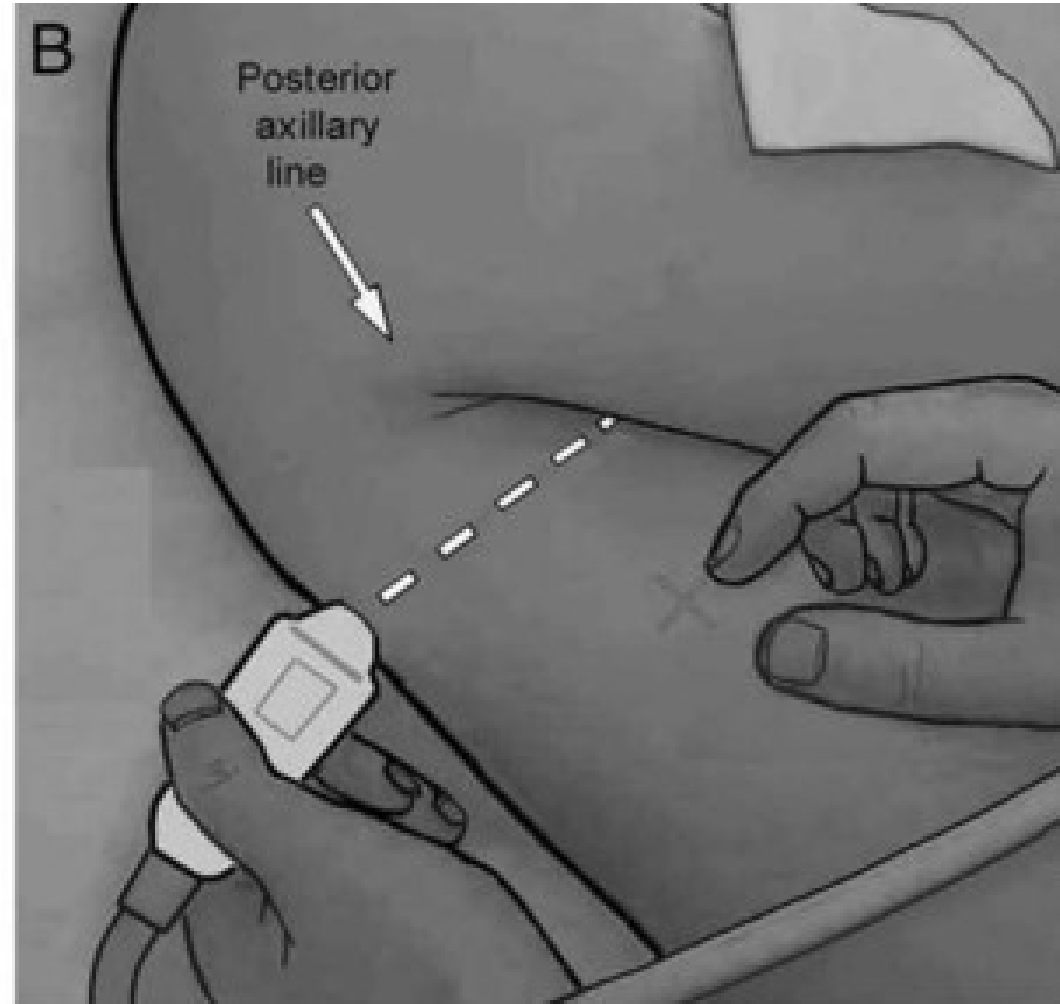



# Lung Ultrasound – Key components

1. Lung sliding: visceral and parietal pleura motion
2. Interpret lung artifacts:
  - A lines: normal finding
  - B lines: lung pathology
  - Sometimes, consolidation is seen
3. Pleural space evaluation

# Lung Ultrasound – Step 1: Lung sliding

- Transducer on chest wall, straddling ribs
- Focus on pleural line deep to ribs (visceral and parietal pleura)
- "Sliding" indicated by shimmering or "ants marching" appearance
- Normal lung sliding rules out PTX
- Absence denotes
  - Pneumothorax
  - Consolidation
  - Pleural disease/mass/pleurodesis
  - Emphysema

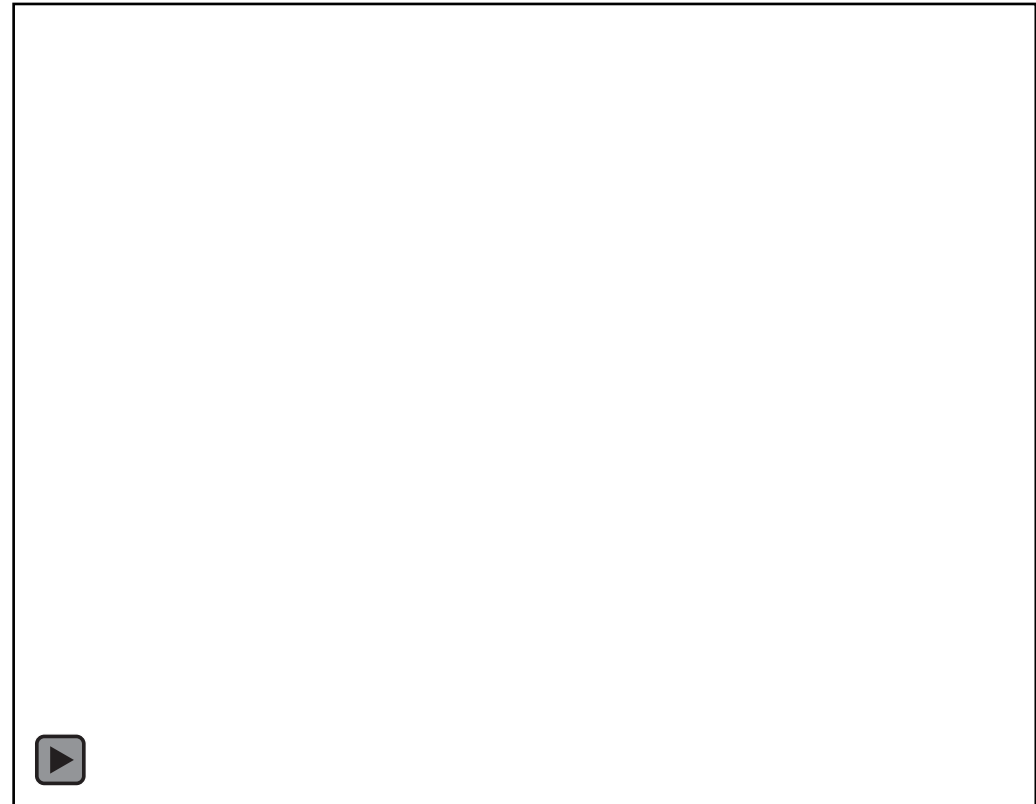

# Lung Ultrasound – Step 2: A lines artifact

- A lines are horizontal lines on the screen at regular interval
- A lines represent reverberation of the ultrasound signal from the pleura
- Presence of A lines signifies presence of air (normal)



# Lung Ultrasound – Step 2: B lines artifact

- Vertical lines from pleura
- 4 or more is abnormal
- Obliterate A lines
- Move with lung
- Extend to edge of screen (18cm)
- B-lines indicate abnormality in interstitial or alveolar compartment
- Can represent alveolar fluid, or interstitial thickening (fluid or fibrosis)
- Pulmonary edema: **minimum 2 positive zones and bilateral**

# Lung Ultrasound – B lines

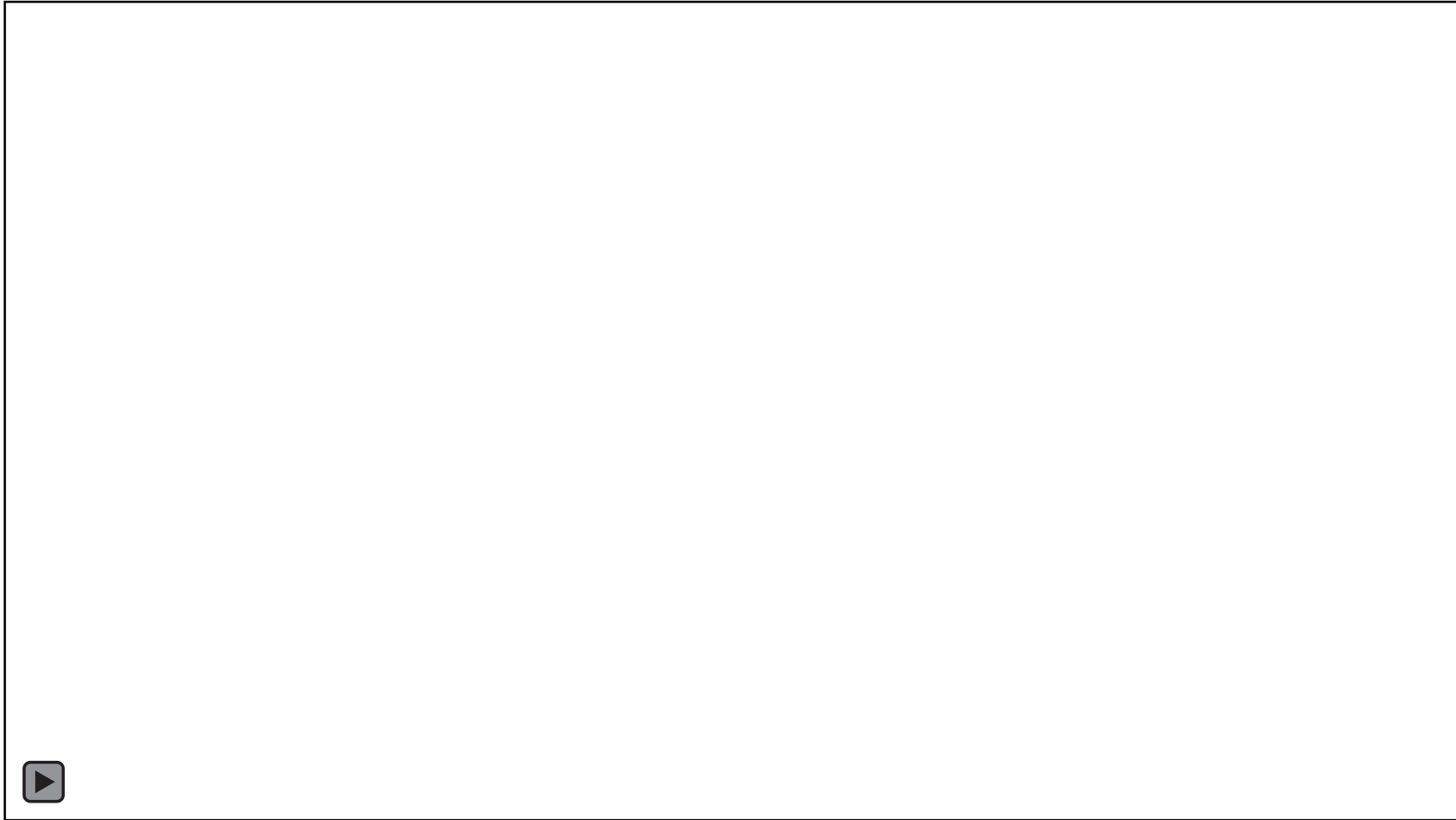





# Lung Ultrasound – Step 2: Pleural effusion

- Costophrenic view (Zone 3)
- Place probe posterior or inferior to Zone 2
- Identify liver (right side) or spleen (left side) and diaphragm
- Pleural fluid appears dark (anechoic) just above diaphragm



# Lung Ultrasound - Interpretation

## Ultrasound findings

- Bilateral B-lines +/- effusion 
- Focal B-lines +/- effusion 
- No lung sliding 
- A-lines and lung sliding 

## Clinical interpretation

- Pulmonary edema/HF
- Pneumonia
- Pneumothorax
- COPD/asthma or PE

# Lung Ultrasound – Exam/breakout

1. Is there lung sliding?
2. Is there artifact?:
  - Are there A lines?
  - Are there B lines?
3. Is there a pleural effusion?



# Lung POCUS - Summary

- Reviewed **basics of operating** a POCUS device
- Discussed **benefit** of performing lung POCUS
- Practiced performing **lung ultrasound**
- Interest in POCUS?
- See links attached

# POCUS articles and interest links

- Ultrasound for Primary Care. Bornemann PH. 2021
- Point of Care Ultrasonography. Arnold MJ, Jonas CE, Carter RE. Am Fam Physician. 2020;101(5):275-285.  
<https://www.aafp.org/pubs/afp/issues/2020/0301/p275.html>
- Relevance of Lung Ultrasound in the Diagnosis of Acute Respiratory Failure: The BLUE Protocol. Lichtenstein DA, Meziere GA. CHEST 2008; 134:117–125
- Validity of Lung Ultrasound: Is an Image Worth More Than a Thousand Sounds? Ramoz-Hernandez C et al. J. Clin. Med. 2021, 10, 2292

# POCUS articles and interest links

- Butterfly IQ: <https://www.butterflynetwork.com/>
- GUSI: Global Ultrasound Institute:  
<https://globalultrasoundinstitute.com/>
- University of South Carolina: Ultrasound Education - School of Medicine Columbia | University of South Carolina.  
[https://sc.edu/study/colleges\\_schools/medicine/centers\\_and\\_institutes\\_new/ultrasound\\_institute/education.php](https://sc.edu/study/colleges_schools/medicine/centers_and_institutes_new/ultrasound_institute/education.php)

# Cracking the Code on Continuous Glucose Monitors (CGMs): A Practical Guide for Providers

UPMC St Margaret Pharmacy  
Residency Program

**UPMC**  
LIFE CHANGING MEDICINE



Scan this code to  
download Dexcom G7  
mobile application

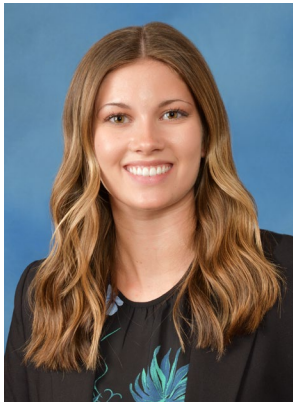

**Alexa Wardoclip, PharmD, BCPS**  
PGY2 Ambulatory Care Pharmacy Resident  
Faculty Development Fellow



**Jason Fine, PharmD, BCPS**  
PGY2 Ambulatory Care Pharmacy Resident  
Faculty Development Fellow

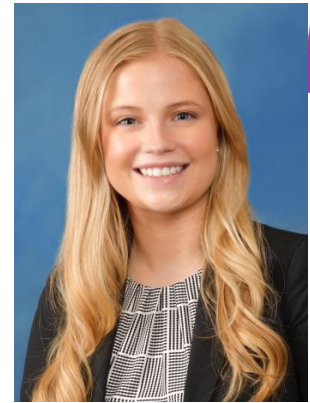

**Madeline Stanko, PharmD**  
PGY2 Ambulatory Care Pharmacy Resident  
Faculty Development Fellow



**Devon Hess, PharmD, MBA**  
PGY1 Pharmacy Resident  
Faculty Development Fellow



**Lauren Fasth, PharmD**  
PGY1 Pharmacy Resident  
Faculty Development Fellow

# Objectives

**Recall** the purpose and at least 2 components of CGMs

**Discuss** how to:

- Order CGMs
- Initial set up of CGM
- Reviewing & interpreting CGM data

**Apply** new knowledge to patient case example

# Disclosure

None of the presenters have any conflicts of interest to disclose.

# Introduction



Background

Ordering a CGM

Initial set up of CGM

Reviewing & interpreting CGM data

# Introduction

- Continuous glucose monitors (CGM) allow for real time glucose information to guide treatment
- Can connect to many smart phones
- Provide peace of mind for patients: alarms to alert patients about lows
- Improved patient satisfaction without the use of multiple daily finger sticks
- Data for providers to adjust treatment regimens
- Information regarding glycemic control between A1c's

# Ordering a CGM

# CGM Options

	<b>Freestyle Libre 3 Plus</b>	<b>Dexcom G7</b>	<b>Dexcom G6</b>	<b>Stelo</b>
<b>Sensor Life</b>	Up to 15 days	Up to 10 days	Up to 10 days	Up to 15 days
<b>Time Between Readings</b>	1 minute	5 minutes	5 minutes	15 minutes
<b>Length of Warm-up Period</b>	1 hour	30 minutes	2 hours	--
<b>Body sites with FDA approval</b>	Upper arm	Upper arm, buttocks	Abdomen, buttocks	--
<b>FDA pregnancy approval</b>	Yes	Yes	No	--
<b>FDA approved age</b>	≥ 4 yr	≥ 2 yr	≥ 2 yr	--
<b>Pearls</b>	Replacing Freestyle Libre 2 and 3	Sensor only, transmitter no longer needed	Separate sensor/transmitter	OTC Product



# Ordering CGM Supplies – Dexcom G7

3 sensors/30  
days!

**Blood-Glucose Sensor (DEXCOM G7 SENSOR) misc device**

Product: **DEXCOM G7 SENSOR DEVICE**

Sig Method:

Start Date:   End Date:

Dispense:  each Refill:

Dispense As Written

Renewal Provider:   Do not send renewal requests to the authorizing provider (None selected)

---

Mark long-term:  BLOOD-GLUCOSE SENSOR

Patient Sig:   
[Edit the patient sig](#)

Report: [Common sizes:](#)  
Box: 1 each, 3 each, 4 each, 5 each | KIT: 1 each

Class:

**ⓘ This medication will not be e-prescribed & a script should be printed** Invalid items: Provider

Note to Pharmacy: [+ Add Note to Pharmacy](#)

Taking:

⌵ [Additional Order Details](#)

# Ordering CGM Supplies – Dexcom G7

Blood-Glucose Meter,Continuous (DEXCOM G7 RECEIVER) misc misc

Product: **DEXCOM G7 RECEIVER**

Sig Method: Specify Dose, Route, Frequency | Taper/Ramp | Combination Dosage | **Use Free Text**

Start Date:  End Date:

Dispense:  each Refill:

Dispense As Written

Renewal Provider:   Do not send renewal requests to the authorizing provider (None selected)

---

Mark long-term:  BLOOD-GLUCOSE METER,CONTINUOUS

Patient Sig: **Use as directed**  
[Edit the patient sig](#)

Report: [Common sizes:](#)  
Box: 1 each | KIT: 1 each

Class:   NO PRINTOUT **Normal**  Historical Med  Sample  Single Page Script  Meds 3 Per Page  
 OTC

**This medication will not be e-prescribed & a script should be printed** Invalid items: **Provider**

Note to Pharmacy: [+ Add Note to Pharmacy](#)

Taking:

[Additional Order Details](#)

1 receiver, 0  
refills

# Ordering CGM Supplies – Freestyle Libre 3

**Blood-Glucose Sensor (FREESTYLE LIBRE 3 PLUS SENSOR) misc device**

Product: **FREESTYLE LIBRE 3 PLUS SENSOR DEVICE**

Sig Method: Specify Dose, Route, Frequency | Taper/Ramp | Combination Dosage | **Use Free Text**

Start Date: 2/8/2025 End Date:

Dispense: 2 each Refill: 11

**Dispense As Written**

Renewal Provider:   Do not send renewal requests to the authorizing provider (None selected)

---

Mark long-term:  BLOOD-GLUCOSE SENSOR

Patient Sig: **Use as directed**  
[Edit the patient sig](#)

Report: [Common sizes:](#)  
Box: 1 each, 3 each, 4 each, 5 each | KIT: 1 each

Class: Normal NO PRINTOUT | **Normal** | Historical Med | Sample | Single Page Script | Meds 3 Per Page  
OTC

**ⓘ This medication will not be e-prescribed & a script should be printed** Invalid items: Provider

Note to Pharmacy: **+ Add Note to Pharmacy**

Taking:

⌵ [Additional Order Details](#)

Next Required  Accept  Cancel

2 sensors/30 days!



# Ordering CGM Supplies – Freestyle Libre 3

Blood-Glucose Meter,Continuous (FREESTYLE LIBRE 3 READER) misc misc

Product: **FREESTYLE LIBRE 3 READER**

Sig Method:

Start Date:   End Date:

Dispense:  each Refill:

Dispense As Written

Renewal Provider:    Do not send renewal requests to the authorizing provider (None selected)

1 reader, 0 refills!

Mark long-term:  BLOOD-GLUCOSE METER,CONTINUOUS

Patient Sig:

[✎ Edit the patient sig](#)

Report: [Common sizes:](#)  
Box: 1 each | KIT: 1 each

Class:

**ⓘ This medication will not be e-prescribed & a script should be printed** Invalid items: **Provider**

Note to Pharmacy: [+ Add Note to Pharmacy](#)

Taking:

[⌵ Additional Order Details](#)

# CGM Supplies & Medicare

- Order through Parachute Health
  - Common suppliers: Byram Health, CCS Medical, etc.
- Billed through Medicare Part B
- Can get shipped to office or patient's home



# Insurance Coverage

## Freestyle

### Medicare

Requirements

1 or more insulin injection **OR** problematic hypoglycemia

Where to send

Durable medical supply company (i.e. CCS Medical)\*

### Medicaid

Requirements

None

Where to send

Pharmacy

### UPMC Commercial \*\*

Requirements

Problematic hypoglycemia **AND** 1 or more insulin injections

Where to send

Pharmacy

### Highmark & Aetna Commercial \*\*

Requirements

Multiple daily injections

Where to send

Durable medical supply company

\*For United Health care, Humana, & UPMC Medicare insurances: send to pharmacy (same requirements)

\*\*Patients can always get 2 sensors at the pharmacy for \$74.99/month if not on insulin

# Dexcom – Cost & Coverage

## Dexcom Cost & Coverage Estimator



### Dexcom Coverage Evaluator

This tool evaluates Dexcom pharmacy coverage for clinicians and determines the most affordable option for each patient.

Simply input the patient information along with NPI in the form below to receive coverage results, recommended action, and consideration.

Verifying patient information is accurate is crucial for determining coverage.

Patient First Name \*

Patient Last Name \*

Patient Date of Birth \*

Patient Gender \*

Patient Zip Code \*

A valid 5 digit zip code.

Provider NPI Number \*

Provider's 10 digit NPI number.

# Dexcom Coverage

Plan	Plan Name	Status	Requirements
<b>Medicare</b>	UPMC Health Plan For Life	No Manual PA	At least once daily insulin or problematic hypoglycemia
	Aetna – MA	No Manual PA	
<b>Managed Medicaid</b>	UPMC Health Plan For You (PA)	Preferred (PA/ST)	Diabetes diagnosis and on any diabetes medication
	Highmark Wholecare (PA)	Preferred (PA/ST)	
<b>Commercial</b>	UPMC Health Plan	No Manual PA	At least 1 daily injection of insulin
	Omni Hotels (OptumRx)	No Manual PA	
	Highmark Blue Cross Blue Shield	Preferred	

PA/ST = Prior Auth/Step Therapy



# Initial CGM Set-Up Visit

Disclaimer: The graphics and information come directly from Dexcom / Freestyle Libre



# Initial Visit

- Introduce CGM and Components

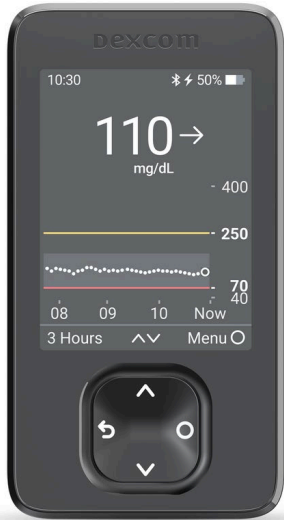

# Initial Visit

## App/ Device pairing

- Phone
  - Download Dexcom G7 app → create account
  - Download Dexcom clarity → login with same credentials
    - No longer required for data sharing
- Reader
  - Set date and time



Dexcom G7



Dexcom G6



Dexcom Clarity

# Apps



## Dexcom G7 app

- **Who uses it?** The person wearing the Dexcom G7.
- **What does it do?** Shows user's glucose information.



## Dexcom Clarity app

- **Who uses it?** Dexcom G7 user wearing the sensor.
- **What does it do?** Review key metrics, create reports, or authorize data sharing with your clinic.



## Dexcom Follow app\*

- **Who uses it?** Someone who wants to view Dexcom G7 user's data. Examples: Parents, spouse, or caregivers.
- **What does it do?** Allows a person to view and follow the glucose levels and trends of a loved one.

\*Internet connectivity required for data sharing. Following requires the use of the Follow app. Followers should always confirm readings on the Dexcom G7 app or receiver before making treatment decisions.

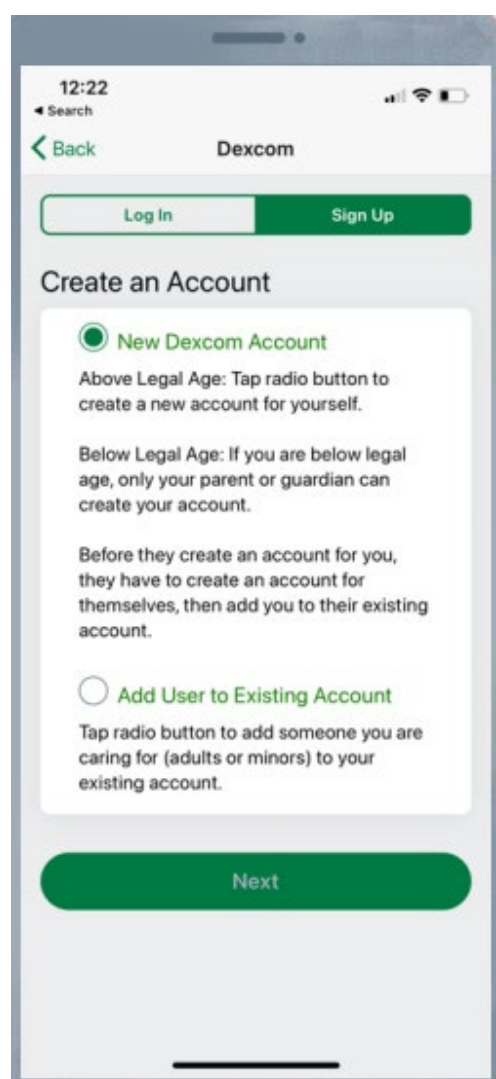
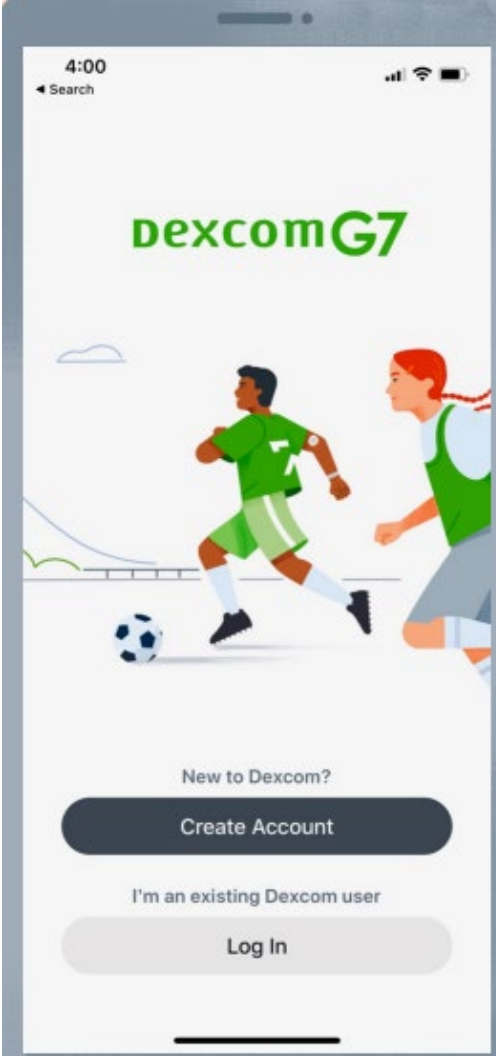

# Overview Walkthrough

- The app walks you through the entire setup process step-by-step.
  - G7 Basics
  - Sensor readings (video and text versions available)
  - Alerts (video and text versions available)
  - When to use your blood glucose meter (video and text versions available)
  - Safety

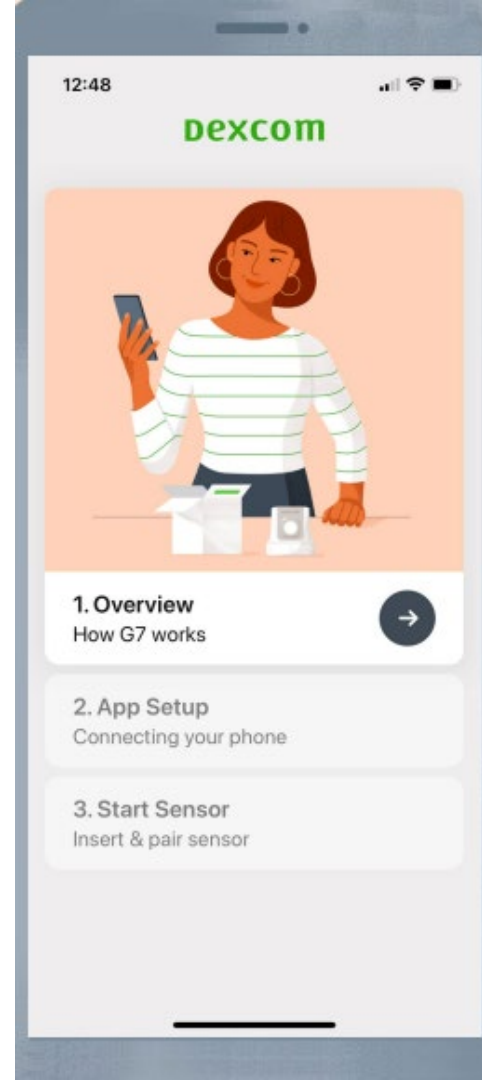

# App Setup

- Enabling Bluetooth (must be on for the system to work)
- Setting other required phone settings (Android and iOS are different)

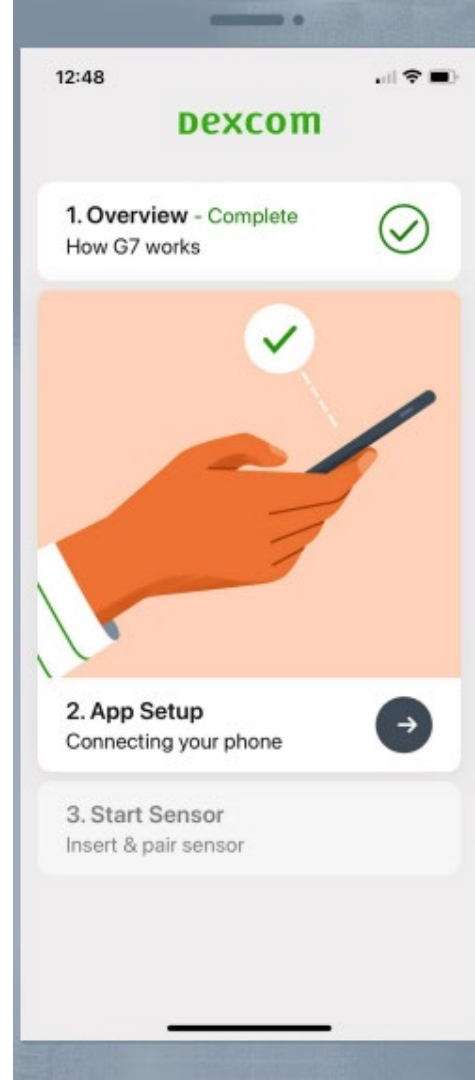

# Start Sensor

## Avoid areas:

- With loose skin or without enough fat to avoid muscles and bones
- That get bumped, pushed, or you lie on while sleeping
- Within 8 centimeters of infusion or injection site
- Near waistband or with irritations, scarring, tattoos, or lots of hair

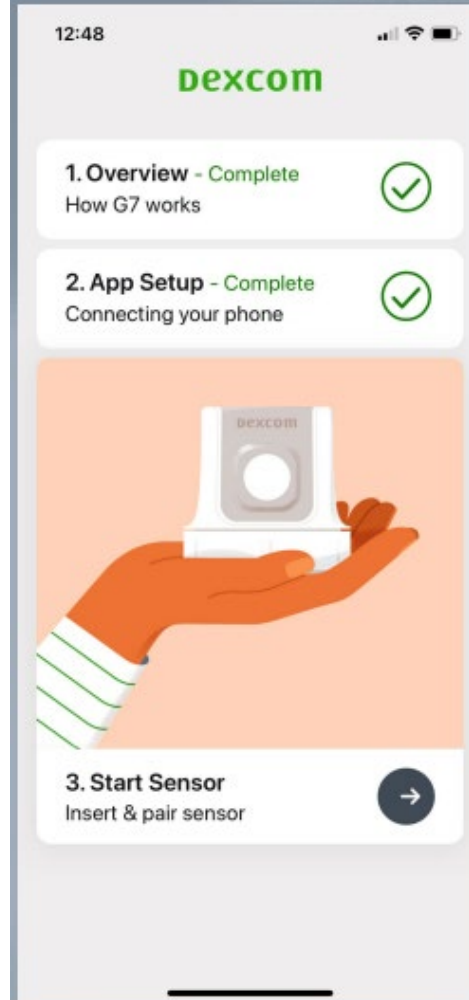



Wash hands with soap and water. Dry.



Rub site with an alcohol wipe. Wait until dry.



Unscrew cap. Don't touch inside applicator.



Press and hold applicator firmly against skin and then push button.



Remove applicator.



Rub firmly around patch 3 times.



Gently press on top of sensor for 10 seconds.



# Apply Over-Patch

- Bundled in the patient instructions in the sensor box

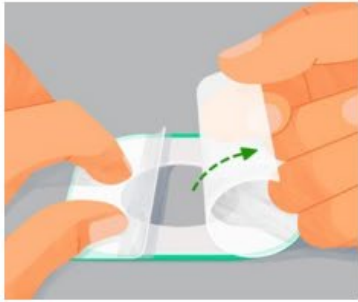

Carefully pull off both clear liners, one at a time. Don't touch white adhesive area.



Use colored tab to place overpatch around sensor.



Rub around overpatch.



Use tab to peel off colored liner.



Rub around overpatch.

# Pair Sensor with Device

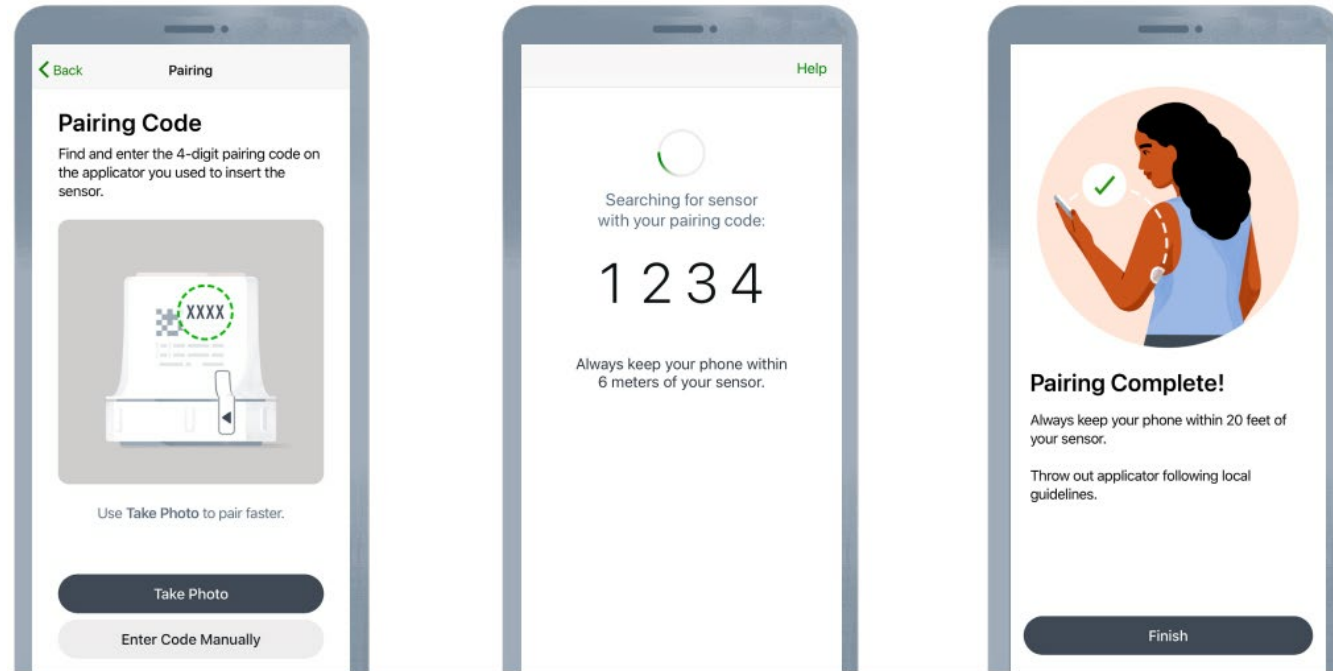

# Warmup

- This will happen each time it is paired
- Once communication is confirmed, the warmup starts
- The sensor warmup timer tells you when readings and alerts will start
- The warmup starts at sensor insertion, so you may see fewer than 30 minutes
- Keep smart device within 6 meters during this time

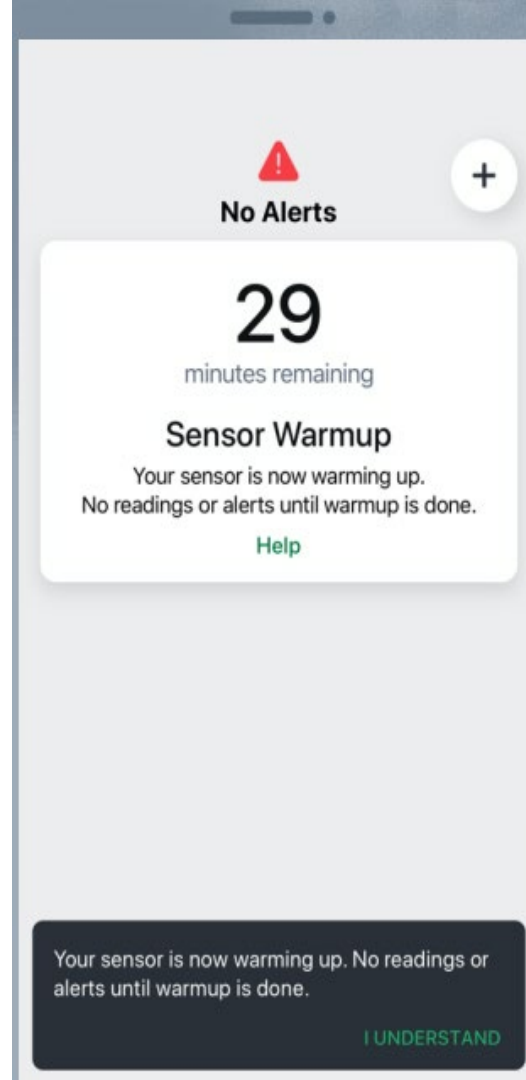

Current Sensor Reading

Add Event

Trend Arrow

Hours Shown

Edit Alerts

High Alert Level

Trend Graph

(scrub along to view past glucose values)

Low Alert Level

Current Sensor Reading

Clarity Card

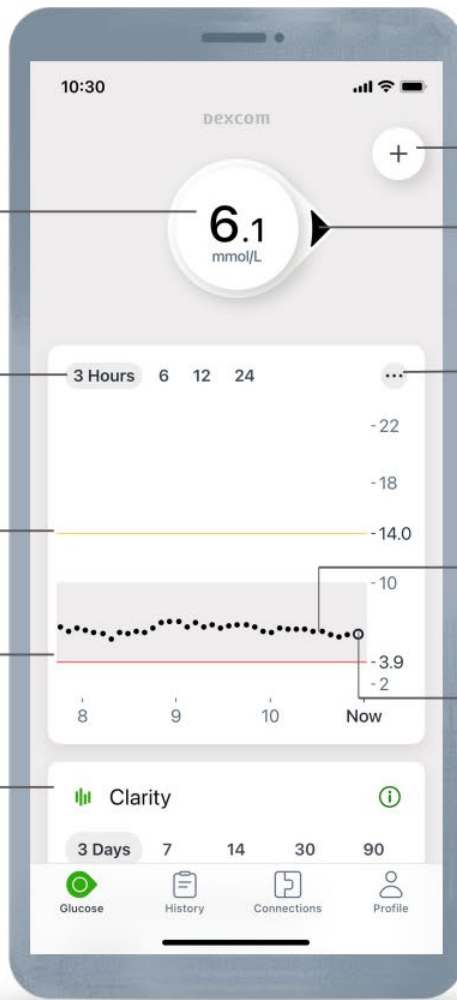

# Review the Basics



**Steady**  
Changing less  
than 0.8 mmol/L  
in 15 minutes



**Slowly rising or falling**  
Changing  
0.8-1.7 mmol/L  
in 15 minutes



**Rising or falling**  
Changing  
1.7-2.5 mmol/L  
in 15 minutes



**Rapidly rising or falling**  
Changing more  
than 2.5 mmol/L  
in 15 minutes

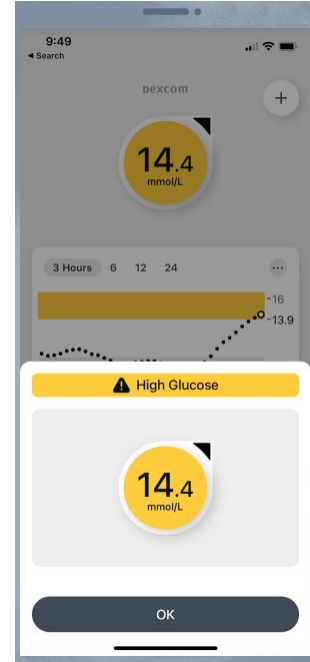
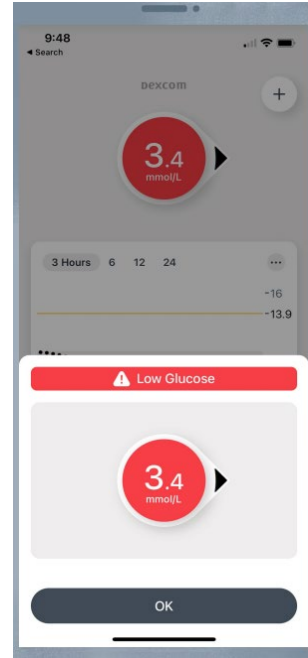

# Setup data sharing (Dexcom Clarity)

Add patient to list  
(provider  
professional  
account)

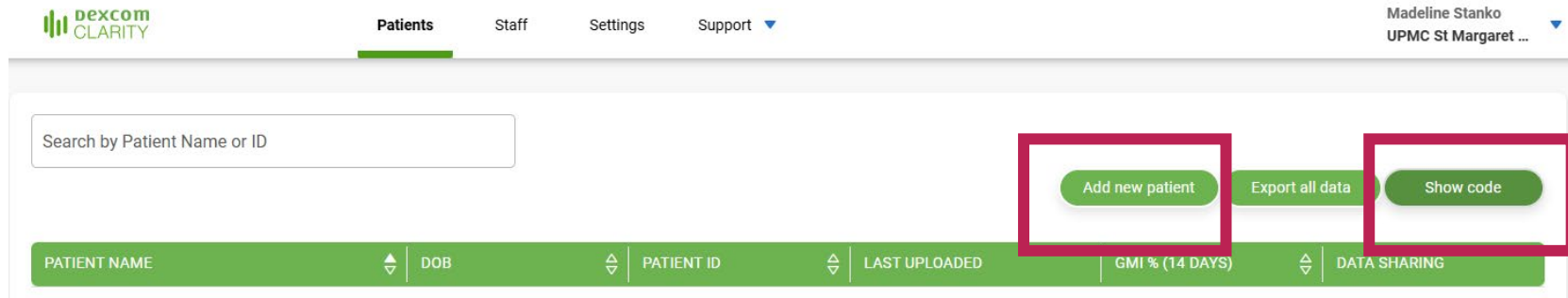
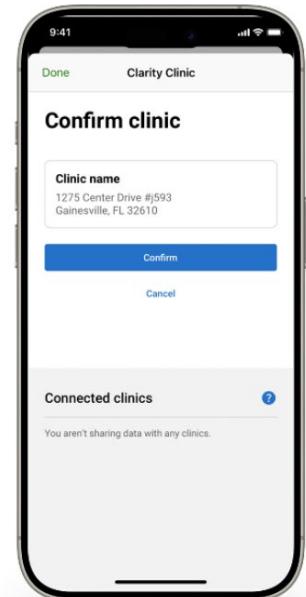
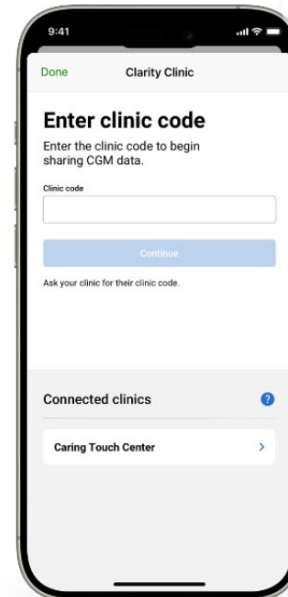
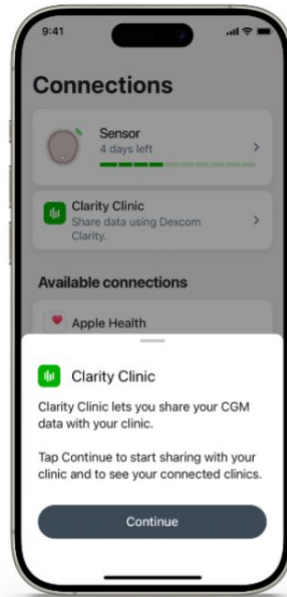

# Freestyle Libre

## Invite Patient

## Date of Birth

## Link Patient

Link patient to a LibreView Practice or as a Private Patient.

Members of this Practice's Care Team will have access to this patient.

## LibreView Account

Invite patient to upload and share their glucose data remotely.

# Information for the Patient

- It may take 24 hours for sugars to normalize
- Keep phone/reader within 20 feet of sensor
- If CGM does not match symptoms, check with glucometer



## End of Sensor/ Removing

- Sensor lasts for 10 days (12-hour grace period)
- To make it easier and avoid irritating skin:
  - Loosen edge and soak patch in body oil, like baby oil or an adhesive remover for skin (alcohol wipe)
  - Use adhesive removal wipes to rub the skin that gets exposed as you peel back the patch

# Keep Sensor On When...

- **Showering & Bathing** – Waterproof up to 24 hours (G7)
- **Swimming** – Waterproof up to 8 feet deep for 24 hours
- **Exercise & Sweating** – Adhesive may loosen but reinforcement (tape/overlay patches) can help
- **Sleep** – No need to remove it overnight
- **Airport Security** – Safe through metal detectors and body scanners; avoid x-ray machines
- **Mild Skin Irritation** – If not severe, try barrier wipes, different site placement, or medical tape

# Remove Sensor When...

- **Imaging** – MRI, CT Scan, X-rays, or Radiation Therapy
- **Severe Skin Reaction** or Infection
- **Sensor Expiration** – G7: Remove after 10 days (auto shut-off).
- **Prolonged Water Exposure** (>24 hours) – Dexcom is water-resistant but not designed for extended soaking.
- **Surgery** – Remove before procedures where medical staff require it

# Troubleshooting

- Always keep sensor box/applicator until end of 10 days
- If problems with sensor (not working/ falls off) remove sensor and place new one
- Call manufacturer – explain error and request replacement
- Manufacturer phone #s:
  - Dexcom: 888-738-3646
  - Freestyle: 1-855-632-8658

# Freestyle Libre

FreeStyle  
**Libre**

How to start  
using the FreeStyle  
Libre App\*

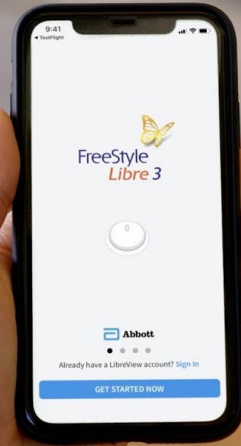

FreeStyle  
**Libre**

Applying the  
FreeStyle Libre  
3 Sensor



# UPMC Billing

- **Billing**
  - 95249 – first time you see the patient to review CGM set up **AND** interpret at least 72 hours' worth of CGM data
  - 95251 – code you can bill once every 30 days for CGM interpretation
- **Revenue**
- **Improving STAR ratings**

# Data Interpretation

# DISCLAIMER

- Additional software is needed on the *physical* computer that is connected to a reader device
- At UPMC, information technology can download the driver needed to upload data
- This is not needed for viewing and interpreting data from patients that share remotely



# Dexcom

## Steps to download:

1. Log into Dexcom Clarity website
2. Search for patient / add new patient
3. If remote sharing, can print / save report
4. If patient has a reader, plug in reader device and select patient
5. Upload the data
6. Print / save report

# Dexcom



Patients

Staff

Settings

Support ▾

Marianne Koenig  
UPMC New Kensing... ▾

Search by Patient Name or ID

Add new patient

Export all data

Show code

PATIENT NAME



DOB



PATIENT ID



LAST UPLOADED

GMI % (14 DAYS)



DATA SHARING

# Dexcom



Patients

Staff

Settings

Support ▾

Marianne Koenig  
UPMC New Kensing... ▾

Add new patient

Export all data

Show code

PATIENT NAME



DOB



PATIENT ID



LAST UPLOADED

GMI % (14 DAYS)



DATA SHARING

Jan 30, 2025

8.3%

✖ Off



Upload data



Save or print report



Go to interactive reports

Delete

Edit

Export

joint.com

# Upload Data

PATIENT NAME	DOB	PATIENT ID	LAST UPLOADED	DATA SHARING
			Jan 30, 2025 4:06 PM	✘ Off



Verify

2

**Connect Device**

3

Collect Data

4

Success

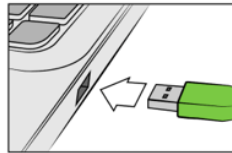

1. Connect the USB cable to your computer.

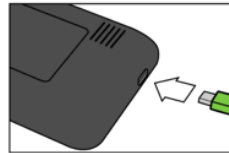

2. Connect the cable to your receiver.



3. Press and hold the power button on the receiver until it turns on.

Cancel

Upload

# Upload Data

PATIENT NAME

DOB

PATIENT ID

LAST UPLOADED

DATA SHARING

Jan 30, 2025 4:06 PM

✖ Off



Verify



Connect Device



**Collect Data**



Success

## Collecting Data

Please wait while data is collected.

Reading...

## Upload Data

PATIENT NAME

DOB

PATIENT ID

LAST UPLOADED

DATA SHARING

Feb 13, 2025 3:34 PM

✖ Off



# Upload complete!

[Upload data](#)[Save or print report](#)[Go to interactive reports](#)[← Return to Patient List](#)

# Save or print report

Primary date range to display:

14 Days Fri Jan 31, 2025 - Thu Feb 13, 2025 

Report sections to display:

Report sections to display:

- Overview
- Patterns
- Overlay
- Daily
- Compare
- Daily Statistics
- Hourly Statistics
- AGP

Color Mode:

Color  Black and White

NOTE: The Compare report will compare the date range selection shown above with the previous 14 days

Save as PDF

Print report

Cancel

- Can change date range for report
- 7 days up to 90 days
- Can upload full PDF to patient chart
- Provide printed reports to patients upon request

# Freestyle Libre

Steps to download:

1. Log into Freestyle LibreView website
2. Search for patient / add new patient
3. If remote sharing, can print / save report
4. If patient has a reader, plug in reader device and select patient
5. Upload the data
6. Print / save report

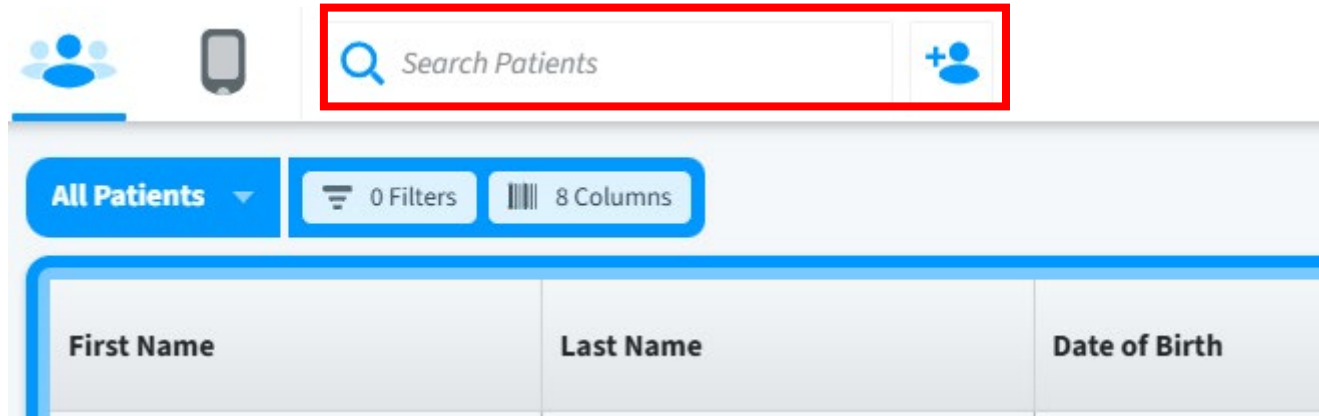





Search Patients



## Profile

 Profile

 Glucose History

 New Kensington FHC

### Identity



Age      Date of Birth      Email

### Connected to LibreView Patient

New glucose data will appear in LibreView when the patient uploads into their personal LibreView account.

### My Practices

Below are the LibreView Practices that have access to view this patient.

 New Kensington FHC

Download all of the patient's glucose data in LibreView. [Download Glucose Data](#)



Search Patients



# Glucose History

2 weeks

Compare

Profile

Glucose History

New Kensington FHC

All Data

FreeStyle Libre

FreeStyle Libre Pro

## New Glucose Data

View glucose history below or click **Glucose Reports** to create customized reports you can view now or print/save as PDFs.



Glucose Reports

January 31, 2025 - February 13, 2025

FreeStyle Libre 2

252

mg/dL  
Average Glucose

100%

Days of Data

5

Hypo Events

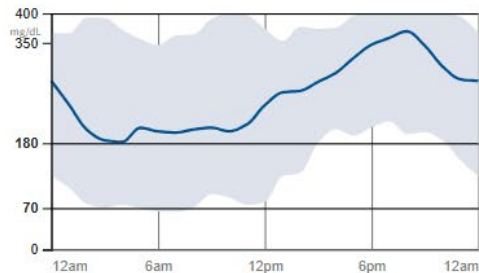



MRN: \_\_\_\_\_  
 DEVICE: FreeStyle Libre 3 + 7

New Kensington FHC  
 PHONE: 724-334-3640

Generated: 02/13/2025

# AGP Report

LibreView

January 31, 2025 - February 13, 2025 (14 Days)

## GLUCOSE STATISTICS AND TARGETS

January 31, 2025 - February 13, 2025 **14 Days**  
**Time CGM Active: 80%**

Ranges And Targets For	Type 1 or Type 2 Diabetes
<b>Glucose Ranges</b>	<b>Targets % of Readings (Time/Day)</b>
Target Range 70-180 mg/dL	Greater than 70% (16h 48min)
Below 70 mg/dL	Less than 4% (58min)
Below 54 mg/dL	Less than 1% (14min)
Above 180 mg/dL	Less than 25% (6h)
Above 250 mg/dL	Less than 5% (1h 12min)
Each 5% increase in time in range (70-180 mg/dL) is clinically beneficial.	

**Average Glucose** 252 mg/dL  
**Glucose Management Indicator (GMI)** 9.3%  
**Glucose Variability** 38.1%

Defined as percent coefficient of variation (%CV); target ≤36%

## TIME IN RANGES

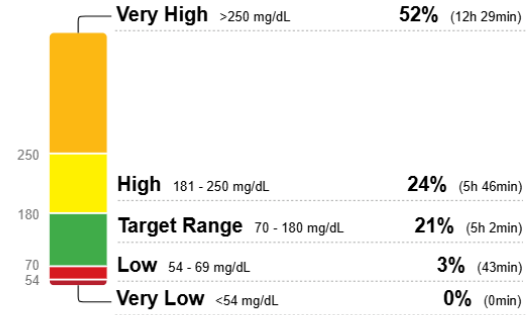

## AMBULATORY GLUCOSE PROFILE (AGP)

AGP is a summary of glucose values from the report period, with median (50%) and other percentiles shown as if occurring in a single day.



Change Report End Date

8 Data Sources

Report Settings

16 pages [Print/Save PDF](#)



Search Patients



## Profile

 Profile

 Glucose History

 New Kensington FHC

### Identity

Edit



Age    Date of Birth    Email

### Invite Patient to Upload From Home

Invite this patient to create a LibreView Account, allowing them to upload and share their glucose data remotely.

Invite Patient

Learn More



Search Patients



## Upload a Device

- 1 Connect the device to your computer with the correct cable
- 2 Choose upload option below

The LibreView Device Drivers software is required to upload a device. [Download the LibreView Device Drivers software](#)



### Create 1-Time Report

Upload a device to view and print a report now.

- Only viewable for 24 hours
- No data saved permanently
- Data cannot be added to a patient's profile

OR



### Create Report Linked to Patient

Upload a device and link to a patient to save the data for viewing at any time.

- Adds data from device to patient's profile
- Saves data for future viewing

## Upload a Device

- 1 Connect the device to your computer using a USB cable
- 2 Choose upload option below

The LibreView Device Drivers software is required to use the LibreView Device Drivers software

### Upload Device



Searching for Device



Do not disconnect device while upload is in progress

Cancel Upload

LibreView Device Drivers Version 3.3.5

Upload a device to view and print a report now.

- Only viewable for 24 hours
- No data saved permanently
- Data cannot be added to a patient's profile

Upload a device and link to a patient to save the data for viewing at any time.

- Adds data from device to patient's profile
- Saves data for future viewing



MRN: \_\_\_\_\_  
 DEVICE: FreeStyle Libre 3 + 7

New Kensington FHC  
 PHONE: 724-334-3640

Generated: 02/13/2025

# AGP Report

LibreView

January 31, 2025 - February 13, 2025 (14 Days)

## GLUCOSE STATISTICS AND TARGETS

January 31, 2025 - February 13, 2025 **14 Days**  
**Time CGM Active: 80%**

Ranges And Targets For Type 1 or Type 2 Diabetes

Glucose Ranges	Targets % of Readings (Time/Day)
Target Range 70-180 mg/dL	Greater than 70% (16h 48min)
Below 70 mg/dL	Less than 4% (58min)
Below 54 mg/dL	Less than 1% (14min)
Above 180 mg/dL	Less than 25% (6h)
Above 250 mg/dL	Less than 5% (1h 12min)

Each 5% increase in time in range (70-180 mg/dL) is clinically beneficial.

**Average Glucose** **252** mg/dL  
**Glucose Management Indicator (GMI)** **9.3%**  
**Glucose Variability** **38.1%**

Defined as percent coefficient of variation (%CV); target ≤36%

## TIME IN RANGES

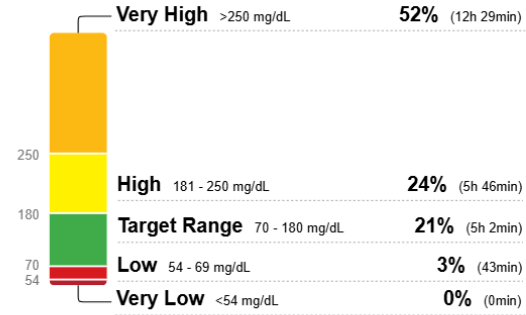

## AMBULATORY GLUCOSE PROFILE (AGP)

AGP is a summary of glucose values from the report period, with median (50%) and other percentiles shown as if occurring in a single day.



Change Report End Date

8 Data Sources

Report Settings

16 pages [Print/Save PDF](#)

# Goal: Flat, Narrow, In-Range

## GLUCOSE STATISTICS AND TARGETS

September 4, 2024 - September 17, 2024 **14 Days**

Time CGM Active: **84%**

Ranges And Targets For	Type 1 or Type 2 Diabetes
<b>Glucose Ranges</b>	<b>Targets % of Readings (Time/Day)</b>
Target Range 70-180 mg/dL	Greater than 70% (16h 48min)
Below 70 mg/dL	Less than 4% (58min)
Below 54 mg/dL	Less than 1% (14min)
Above 180 mg/dL	Less than 25% (6h)
Above 250 mg/dL	Less than 5% (1h 12min)

Each 5% increase in time in range (70-180 mg/dL) is clinically beneficial.

**Average Glucose** **112** mg/dL

**Glucose Management Indicator (GMI)** **6.0%**

**Glucose Variability** **14.0%**

Defined as percent coefficient of variation (%CV); target  $\leq 36\%$

## TIME IN RANGES

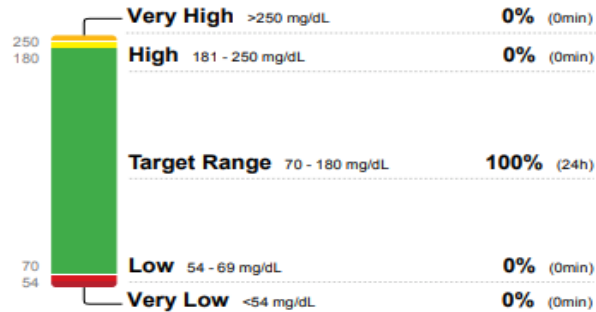

## AMBULATORY GLUCOSE PROFILE (AGP)

AGP is a summary of glucose values from the report period, with median (50%) and other percentiles shown as if occurring in a single day.

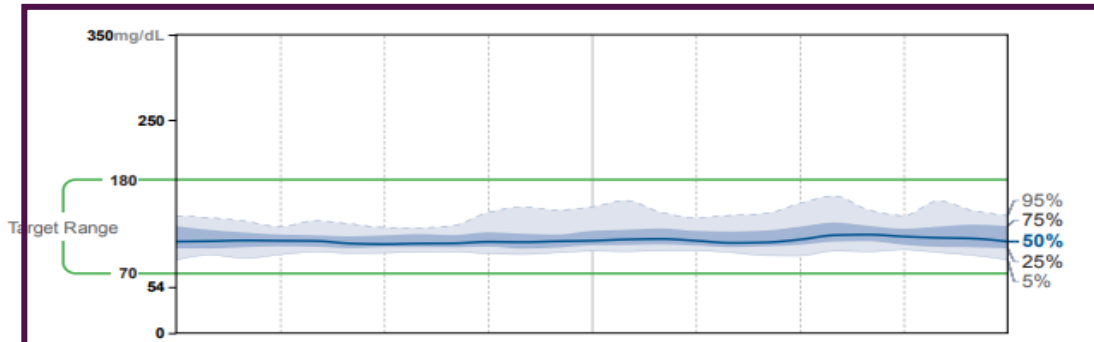



# Interpretation - Overview

## Glucose

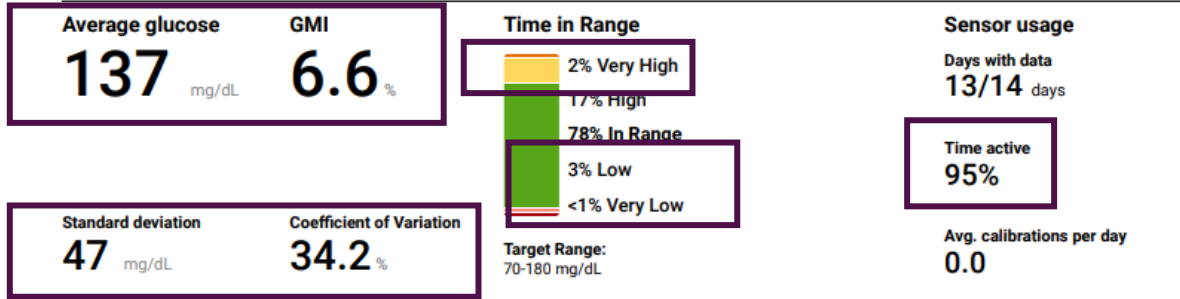

## Top Patterns

**best glucose day was January 17, 2025**  
 Lori's glucose data was in the target range about 99% of the day.

This graph shows your data averaged over 14 days

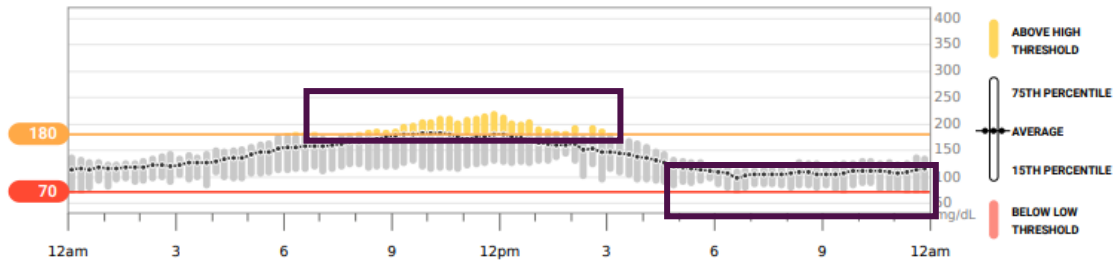

A purple-tinted photograph of the Pittsburgh skyline. The image shows several skyscrapers, including the PPG Place tower with its distinctive pointed top. In the foreground, a suspension bridge spans across a river. The overall scene is set against a cloudy sky.

**UPMC**  
LIFE CHANGING MEDICINE

**LET'S PRACTICE!**

# Interpretation - Patient Case Example

CG is a 65 yo M pt with T2DM, obesity, HTN, and HLD comes into clinic for diabetes f/u.

## **Pertinent Labs/Vitals:**

- A1c 2 months ago: 10.3%
- Last weight: 103 kg

## **Current T2DM Regimen:**

- Metformin 1,000 mg BID
- Jardiance 25 mg daily
- Ozempic 2 mg weekly
- Lantus 30 units qHS
  - ~0.3 units/kg
- Humalog 10 units TID w/meals
- Dexcom G7

# Interpretation - Patient Case Example

Average glucose

**220** mg/dL

GMI

**N/A**

Time in Range

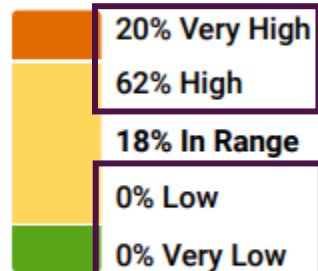

Sensor usage

Days with data  
**4/14** days

Time active  
**67%**

Standard deviation

**42** mg/dL

Coefficient of Variation

**19.2** %

Target Range:  
70-180 mg/dL

Avg. calibrations per day  
**0.0**

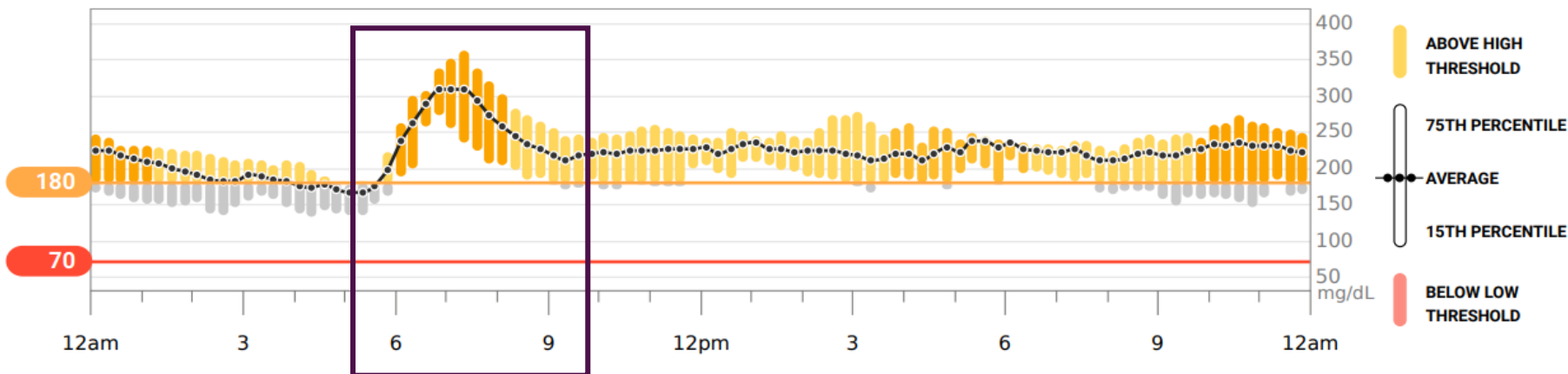

# Interpretation - Patient Case Example

Tue, Feb 4, 2025

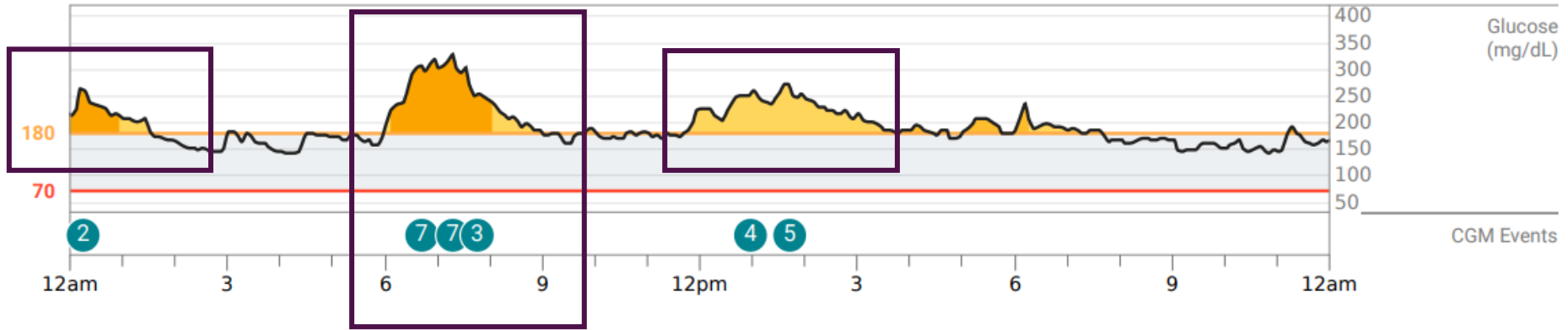

7:51 AM	CGM	Alert	High	--	250 mg/dL
7:46 AM	CGM	Alert	High	--	252 mg/dL
7:36 AM	CGM	Alert	High	--	272 mg/dL
7:31 AM	CGM	Alert	High	--	302 mg/dL
7:26 AM	CGM	Alert	High	--	294 mg/dL
7:21 AM	CGM	Alert	High	--	302 mg/dL
7:16 AM	CGM	Alert	High	--	328 mg/dL
7:11 AM	CGM	Alert	High	--	314 mg/dL
7:06 AM	CGM	Alert	High	--	306 mg/dL

# What Would You Recommend For This Patient?

## Our Recommendation:

- Lifestyle interventions
- Increase Humalog to 12 units with breakfast, 10 units with lunch and dinner
- Increase Lantus to 32 units qHS

Don't Forget to Bill!

### GLUCOSE MONITORING

CONT GLUC MNTR PHYSICIAN/QHP PROVIDED EQUIPMENT  
95250 (CPT@)

CONT GLUC MONITORING PATIENT PROVIDED EQUIPMENT  
95249 (CPT@)

★ CONTINUOUS GLUCOSE MONITORING ANALYSIS I&R  
95251 (CPT@)

Can only bill once  
every 30 days!

# Key Points

CGMs are useful tools to monitor glycemic trends in patients with diabetes and assist in informing medication adjustments, particularly insulin

CGMs initial and interpretation visits utilize different billing codes, and the latter can only be billed once every 30 days

While different patient populations have different targets for glycemic control, the goal CGM trend is flat, narrow, and in-range

# References

- 1) American Diabetes Association Professional Practice Committee. Diabetes Technology: Standards of Care in Diabetes-2025. *Diabetes Care*. 2025;48:S146-S166. doi:10.2337/dc25-S007.
- 2) Abbott. FreeStyle Provider – Continuous Glucose Monitoring (CGM) Systems. Accessed February 10, 2025. <https://www.freestyleprovider.abbott/us-en/home.html>.
- 3) Dexcom Provider – Continuous Glucose Monitoring for Healthcare Providers. Accessed February 10, 2025. <https://provider.dexcom.com>.





# Cracking the Code on Continuous Glucose Monitors (CGMs): A Practical Guide for Providers

UPMC St Margaret Pharmacy  
Residency Program

# Family Medical History in Primary Care

---



# Title Slide

---

Title of Course:

'PCPM: Family Medical History in Primary Care'

Course Presenter:

- Kevin C. Lee, DO
  
- No relationships with industry relevant to the content of this education activity have been disclosed for all parties

# Objectives

---

1. Understanding the role that family medical history plays in identifying genetically testable conditions and how primary care plays a key part in this role
2. Learning high-yield questions to help identify a genetically testable medical condition from the family history
3. Practice creating a medical pedigree in the context of patient care
4. Learning next steps to evaluate the concern for genetically testable conditions found in the family medical history

# Who are we?

---

- A consultant clinic in the UPMC Department of Family Medicine
- A multidisciplinary team of Family Medicine providers, Licensed Genetic Counselors, and Pharmacists
- Mission Aims:
  - Provide Precision Medicine care to the community
  - Research the integration of Precision Medicine into everyday Primary Care
  - Enhance access and equity for Precision Medicine services to the community

# UPMC Primary Care Precision Medicine Clinic

---

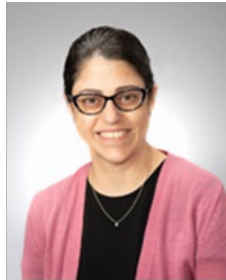

**Mylynda Massart**  
MD, PhD



**Kevin C. Lee**  
DO



**Brianne Phillips**  
DNP, CRNP, FNP-C



**Lucas Berenbrok**  
PharmD, MS, BCACP



**Natasha Berman**  
MA, MS, MPH, CGC



**Christine Munro**  
MS, MPH, CGC



**Lucy Galea**  
MS, CGC

# Key Components to Genetic Testing

---

1. Obtaining the personal/medical history (aka the phenotype)
  - As medical providers, this is our expertise
2. Obtain the Family History (aka the pedigree)
  - Providers: “What is your family history?”
3. Genetic counseling and consent
  - Key role of Genetic Counselors

# Importance of Family History



Accurate family history is a well-established method to identify potential disorders and susceptibilities that may pose future health problems



Family history is the first step to identify patients and start discussions about future health concerns



Allows for personalized risk assessment



Often encourages good rapport building with patients



May open discussion for other concerns a patient may have



# Practitioner Approach Today for FMHx

---

- If a patient comes in for a new physical, how would you ask patients to describe their family history?

# Practitioner Approach Today for FMHx

---

- Most of the time we do not ask for precise questions that quickly identify a family history concern for a genetically testable condition
- We can do better
- And be more efficient!

# Quick Questions to Ask for FMHx 'Red Flag' Screening

---

- Any family history of cancer diagnosed under the age of 50?
  - Ex. Hereditary Breast and Ovarian Cancer, Lynch Syndrome
- Any family history of developmental or intellectual delay in a family member?
  - Ex. Fragile X, Down Syndrome
- Any family history of dementia or neurocognitive decline before the age of 50?
  - Ex. ALS, Frontotemporal Dementia
- Any family history of 3 or more miscarriages, a history of stillbirths or infertility?
  - Ex. Turner Syndrome, Klinefelter Syndrome
- Any history of cardiomyopathy, spontaneous organ rupture, or arrhythmia, sudden cardiac death?
  - Ex. Marfan's Syndrome, vascular Ehlers Danlos Syndrome, Familial hypercholesterolemia, Brugada's
- How would you identify your ancestry or ethnicity?
  - Ex. Ashkenazi Jewish ancestry -> increased risk for BRCA

# 'Red Flags' of the Family History

---

- Cancer:
  - Onset of cancer before the age of 50
  - Cancer in at least 3 or more family members on the same side of the family
  - Rare cancers including pancreatic and ovarian, or metastatic prostate
  - Ashkenazi Jewish ancestry
  - Family history of genetic results (obtain and review the results!)
- Heart Disease
  - Heart Attack/Stroke/Aneurysm/Fatal Arrhythmia before the age of 50
  - Hyperlipidemia requiring medical therapy before the age of 50
  - Elevated LDL >190
  - Spontaneous organ rupture w/o trauma like aneurysms or pneumothorax
  - Spontaneous eye structural condition w/o trauma like lens detachment, vitreous detachment, retinal detachment, corneal rupture
- Genetic Conditions in general
  - Known conditions running in the family
    - Ex. Hereditary hemochromatosis, Alpha-1-antitrypsin, thalassemia, malignant hyperthermia, Factor V Leiden, Familial Mediterranean Fever
  - Prior hx of positive genetic testing results in the family (obtain and review the results!)

# Medical Pedigree

---

# Example of a Medical Pedigree

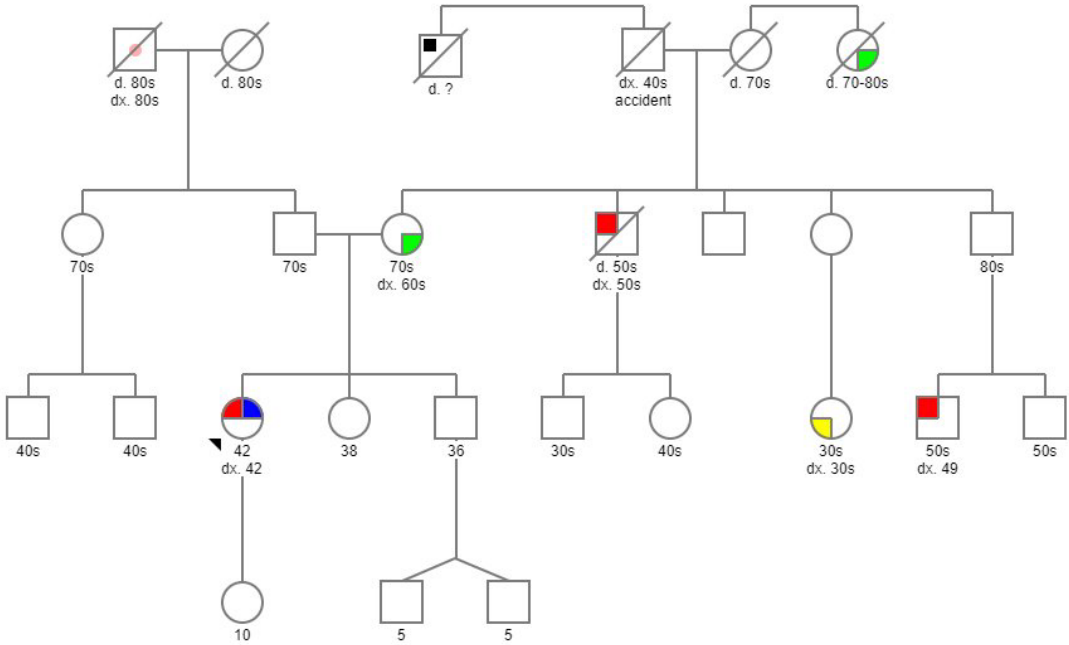

# Steps to Making a Pedigree

---

1. Stop the patient! Tell them that you will go through a step-by-step approach addressing the family members of interest and that you will prompt the patient when you want more information.
2. Pick a Direction (siblings, parents, children). Stick with the generation until done.
3. For each person ask:
  - Alive vs Deceased
  - Current age vs Age deceased
  - Major medical conditions. You can be specific like conditions similar to the patient's presentation, or conditions that were diagnosed young in life like young onset of cancers, neurocognitive decline, or heart disease. If deceased, what did they die from?
4. When you move to the parents, pick a side (paternal or maternal), repeat step 2-3 until you finish a side, then go to the other side
5. Ask about ethnicity/ancestry on paternal and maternal side, and if there is any chance the parents are related to each other by blood (aka. consanguinity).

# Pedigree Demonstration



**RM Partners**  
West London Cancer Alliance  
London, West London, Middlesex, Surrey, Essex, Kent



**NHS**

**Duration: 15 minutes**

**Mainstreaming protocol for  
Lynch syndrome: Genetic testing  
for Lynch syndrome**

1st step: Taking a genetic family history  
E-learning module: 5





# Pedigree Demonstration

---

# Pedigree Practice

---

- With a partner, ask screening questions and draw a medical pedigree
- There are 2 cases, each partner will do one case and set of questions
- 5 minutes for each case (we will call out 'Switch!') for 10 minutes total
- There is a key for the pedigree symbols with each case

# Pedigree Case 1 Answer

**Patient Name:** Case 1    **MRN:** N/A    **DOB:** 1990

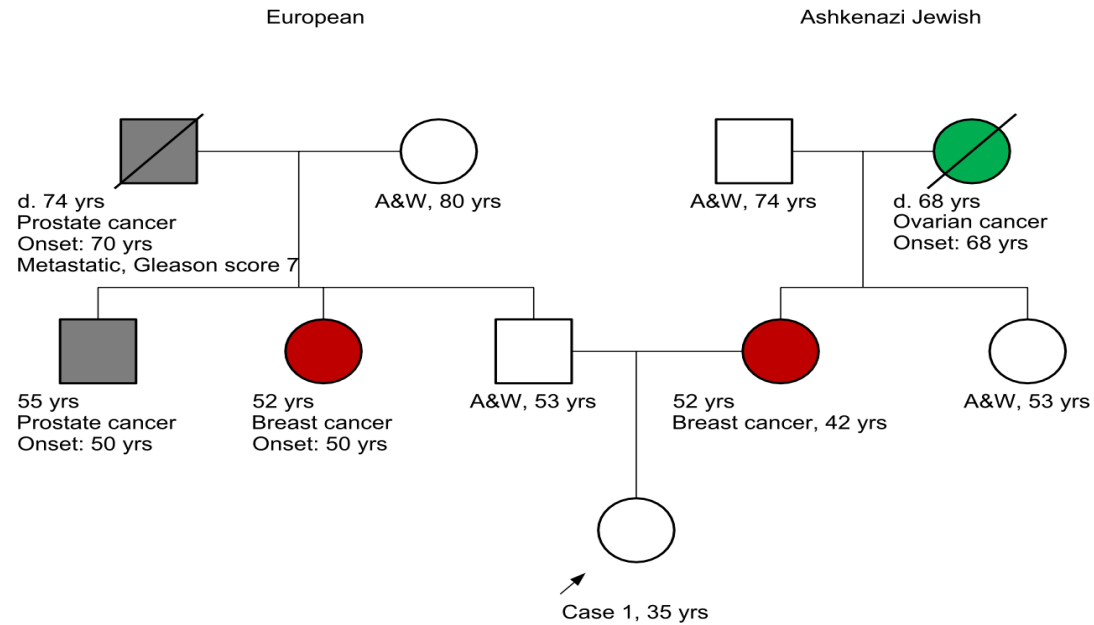

## LEGEND

- Prostate cancer
- Breast cancer
- Ovarian cancer

# Pedigree Case 1 Insights

---

- Patient qualifies for cancer genetic testing due to:
  - Mother with breast cancer dx age 42
  - Maternal Grandmother who had ovarian cancer
  - Paternal Grandfather who had metastatic prostate cancer
  - Paternal Uncle with prostate cancer dx age 50
  - Paternal Aunt with breast cancer dx age 50
  - Maternal ancestry being Ashkenazi Jewish

# Pedigree Case 2 Answer

Patient Name: Case 2

MRN: N/A

DOB: 2002

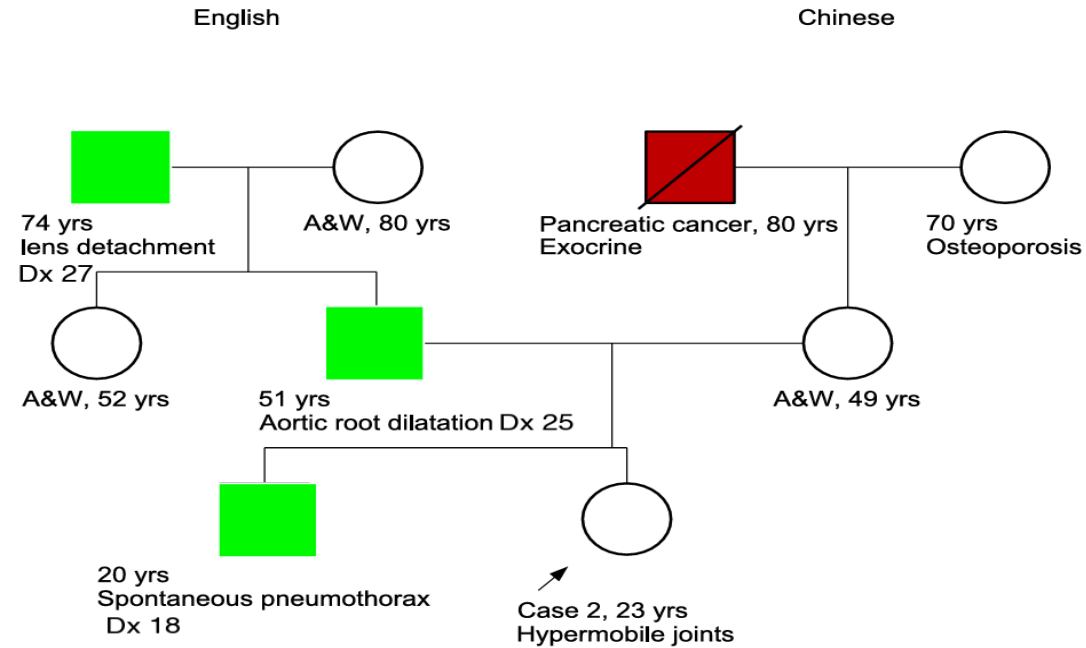

## LEGEND

■ Pancreatic cancer

■ Connective Tissue Disease

# Pedigree Case 2 Insights

---

- Paternal history of connective tissue disease, (ex. Marfan's syndrome)
  - Father with aortic root dilation age 25
  - Paternal grandfather with lens detachment age 27
  - Best candidate for genetic testing would be father, then brother since they are the most affected
- Maternal history of exocrine pancreatic cancer
  - Patient would NOT meet NCCN guidelines for cancer genetic testing... but mother does due to be being the 1st degree relative from the affected maternal grandfather



# Can I bill for this?

---

- Yes!
- If positive on a screening question:
  - Z80.9 Family history of cancer
  - Z82.49 Family history of heart disease
  - Z84.89 Family history of genetic disease
- Bill by time

# What's Next?

---

1. Obtaining the personal/medical history (aka the phenotype) 
  - As medical providers, this is our expertise
2. Obtain the Family History (aka the pedigree) 
  - Providers: “What is your family history?”
3. **Genetic counseling and consent**
  - **Key role of Genetic Counselors**



# Genetic Counselors

---

“Genetic counseling is the process of helping people understand and adapt to the medical, psychological and familial implications of genetic contributions to disease. This process integrates the following:

- Interpretation of family and medical histories to assess the chance of disease occurrence or recurrence.

Education about inheritance, testing, management, prevention, resources and research.

Counseling to promote informed choices and adaptation to the risk or condition. ”

- NSGC Definition Task Force 2006

# How to Consult PCPM

---

- UPMC

- 1) Permission for patient being referred
- 2) "Electronic Consult/Referral to Genetics" in Epic. Please write referral reason
  - Note that this will NOT be a formal electronic consult and will therefore not be billed, but a GC will reply to the consult you on whether or not we will accept the consult after chart review
- 3) Use Smartphrase .pcpmreferral (Username: LEEKC2) to give instructions to the patient to call our central scheduling line (412-647-9304). Please indicate the referral reason in the instructions to remind the patient
  - Even if the consult is accepted by us, it is the patient's responsibility to call central scheduling themselves to schedule the appointment

- Non-UPMC

- 1) Permission for patient being referred
- 2) Referral order faxed to our office (412-863-5788)
- 3) Patient instructions to call our central scheduling line (412-647-9304)

# Consulting PCPM: Things to Note

---

- We do NOT provide continuity care, we will see patients on a consultant basis until the clinical question is adequately addressed
- We are board certified in Family Medicine, not in Medical Genetics, and therefore we may recommend referrals to specialists depending on the clinical case
- Please ensure that any relevant records especially genetic testing records from the patient and/or family members are available for us to review at the time of the visit. Failure to do so will likely result in delays in care such as additional appointments.
- We primarily operate in a telemedicine approach but we also offer in-person appointments.
  - Any patient whose home address is in PA may have their initial and subsequent visits via telemedicine regardless if they are a UPMC patient
  - Any patient whose home address is outside of PA AND are not active UPMC patients MUST have their initial appointment in person. Any subsequent visits can be facilitated via telemedicine.

Thank you!

---

# Medical Cannabis for Chronic Pain: A Blunt Assessment of Efficacy and Risk

Cheryl Bernstein, MD

Associate Professor

Departments of Anesthesiology and Neurology

Division of Pain Management

# Outline

- Background
  - Terminology
  - Medical Cannabis in PA
- Pathophysiology
  - Why medical cannabis for pain
- Certification process
  - Case Presentation
- Efficacy data from our division
- Safety data from our division

# Medical Cannabis Legislation

- April 2016 Medical Marijuana Act signed Pennsylvania
  - Governor Tom Wolf—medical cannabis for approved conditions
- 47 states legalized cannabis for medical use
- 24 states recreational use



# CDC Cannabis Laws Map

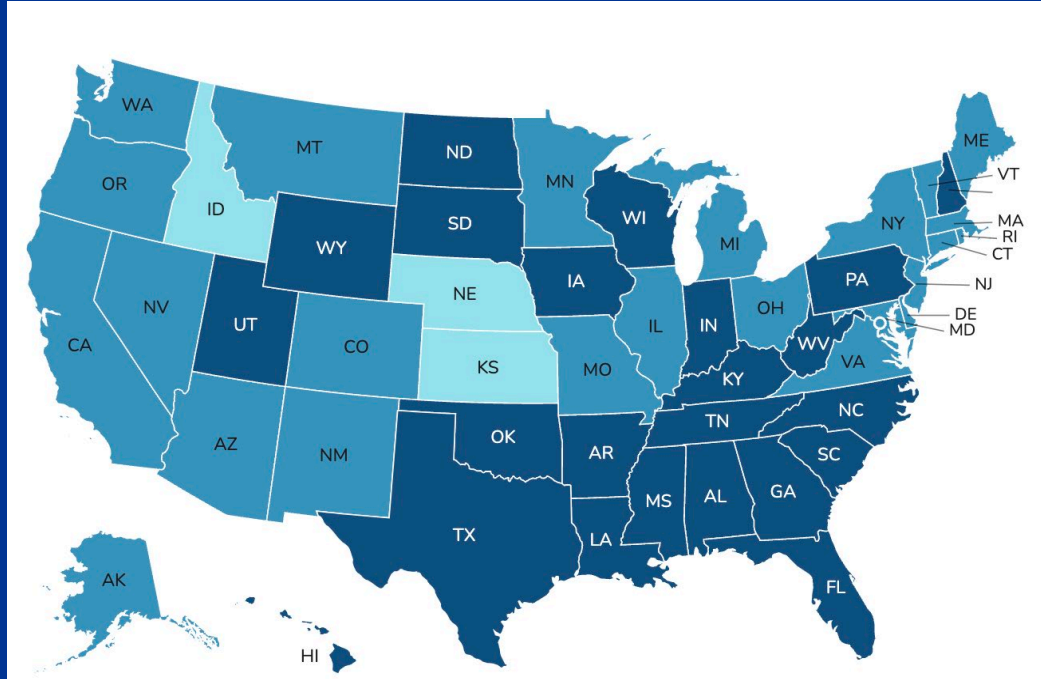

- Medical-only cannabis program
- Adult medical and nonmedical cannabis program
- No public cannabis access program



# PA Medical Marijuana Program Data

**440,733** Active Patient  
Certifications

**1,936** Approved  
Practitioners

**1,003,834** Program-to-date  
patient registrations

**\$904,341.61** MMAP Phase  
3 Financial Benefit Given

**32** Operational  
Grower/Processors

**186** Operational  
Dispensaries

# PA Dispensary Data

## Dispensary Sales by Month Since Jan 2020

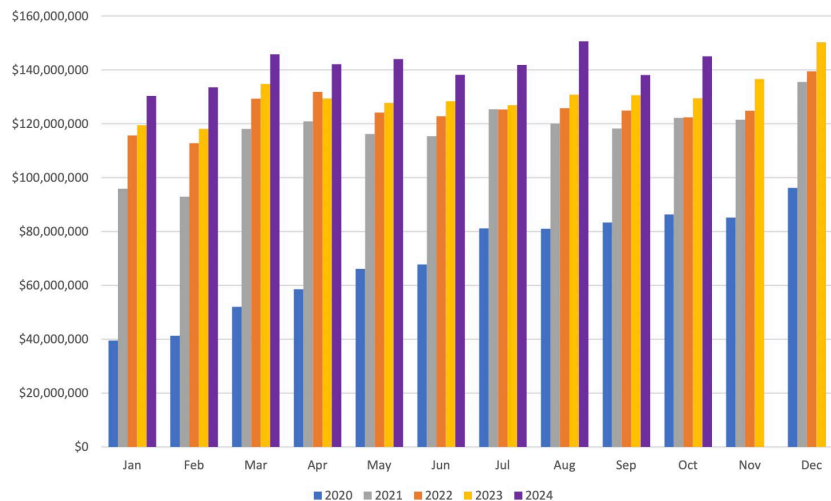

*\$6.7 Billion Sales Program-to-Date*



# Approved Conditions in PA

## Certifications for Anxiety Increasing

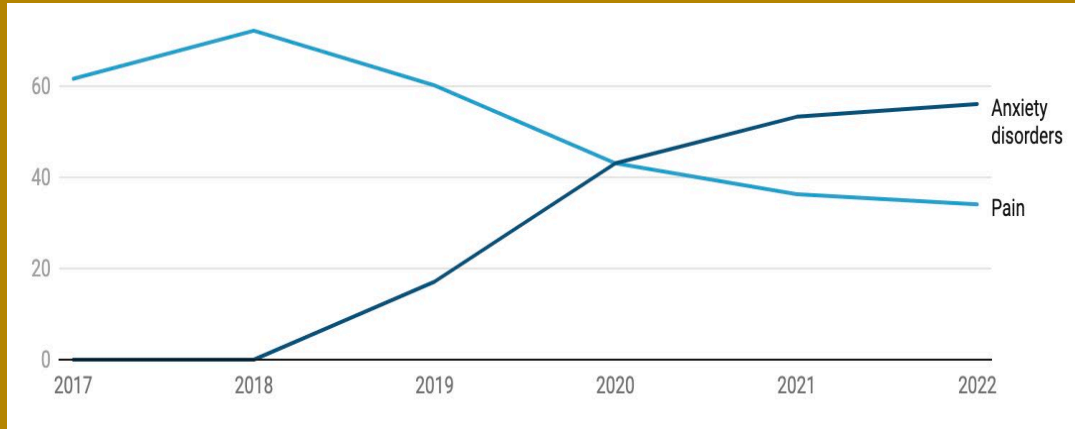

# Terminology



Cannabis (genus of flowering plants)

3 species

*Indica*, *Sativa*, *Ruderalis*



Hemp

*Cannabis Sativa* L.

Low THC < 0.3%

High CBD low THC



Marijuana

*Indica* and *Sativa*

THC > 0.3%

High THC Low CBD

# CBD and THC

	Cannabidiol (CBD)	Tetrahydrocannabinol (THC)
Overview	Hemp plant extract	Marijuana
Chemical Structure	Similar to the endocannabinoids	Similar to the endocannabinoids
Psychoactive effects	None (minimal binding to CB1 receptors) can dampen psychoactive effects of THC	Binds to CB1 receptors in brain and causes euphoria
Side effects	Well tolerated	Increased HR, dry mouth, CNS/psych effects, slow reaction time, memory loss
Drug testing	Should <b>not</b> be present on routine drug testing	Present days to weeks after use
Schedule	None	Schedule 1

# Why Cannabis for Chronic Pain

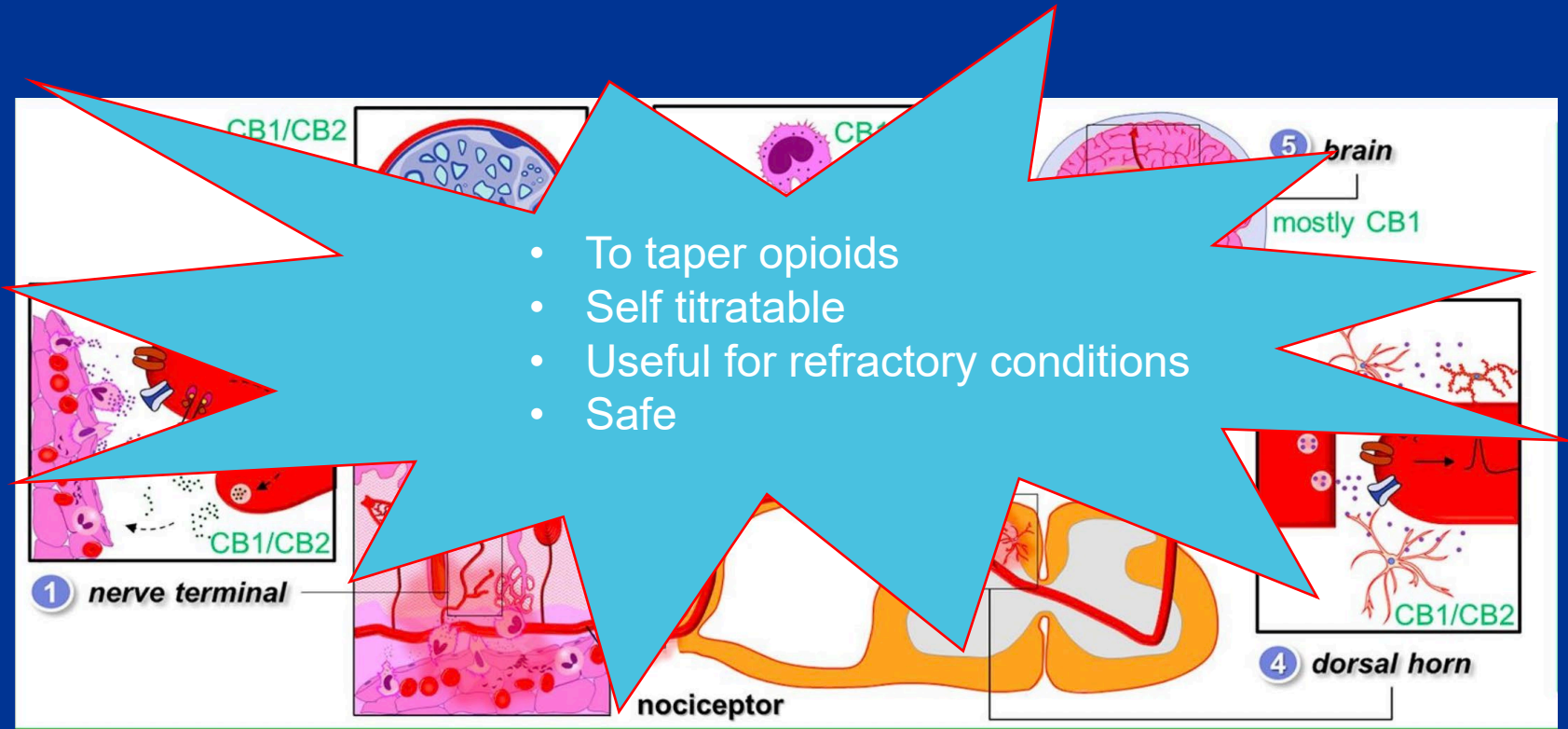

# Medical Cannabis and Chronic Pain

- One of the most common reasons given for medical cannabis
- Five fair-good quality systematic reviews supporting use<sup>1</sup>
  - Most studied neuropathic pain
- Efficacy is a controversial topic<sup>2</sup>
  - Other systematic reviews concluding no benefit

# UPMC Guidelines for Medical Cannabis and Chronic Pain

- Medical marijuana use for pain should not be a first-line treatment
- Use for chronic painful condition likely responsive to cannabis
- Absence of active cannabis use disorder or other substance use disorder
- No history of psychotic disorder
- Attempt to reduce or taper off chronic opioids in those certified



# Case Presentation

- 69 year old woman with bilateral LE > UE pain
  - Hx of scleroderma and eosinophilic fasciitis/overlap syndrome
  - Painful swelling and hardness of the distal limbs
  - Thickened skin
- Initial pain clinic visit 2/21/24
  - Patient seen by another physician in our division
  - Failed gabapentin 1200mg daily
  - Unable to tolerate duloxetine



# Baseline CHOIR Initial Visit

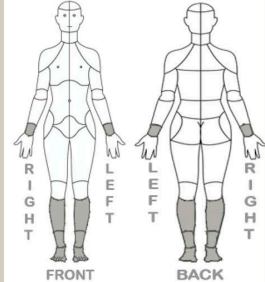

PROMIS Outcomes Measures	Score	%ile	Category
Bank v1.2 - Physical Function *	77	100	
Bank v1.1 - Pain Interference	78	100	
Pain Behavior Bank	66	95	
Bank v1.0 - Sleep Disturbance	64	92	Moderate
Depression Bank	71	98	Severe
HEAL Bank v1.0 - Positive Outlook	33	4	Very Low
Anxiety Bank	67	96	Moderate
Post Traumatic Stress Disorder	0	0	
Initial Treatment Expectancy	100		
Global Health - Physical *	73	99	
Global Health - Mental *	56	73	

16 areas selected on the most recent body map

\* Scores and percentiles have been inverted

**Pain Intensity: 0=No Pain, 10=Worst Pain Imaginable**

Worst	Average	Now
8	7	9

**PainDETECT for Neuropathic Pain**

Score:	28	19-38: Neuropathic. A neuropathic pain component is likely (> 90%).
Radiating pain	No	
Pain course	Pain attacks with pain between them	
Burning pain	Very strongly	
Tingling/Prickling pain	Very strongly	
Light touching painful	Strongly	
Sudden pain attacks	Very strongly	
Hot/Cold painful	Moderately	
Numbness	Hardly noticed	
Slight pressure painful	Strongly	

**Pain Experience**

How long have you had your pain problem?	5 Months
Briefly describe how your pain started	Swelling in my left leg.
Describe your current pain	Shooting, Stabbing, Sharp, Gnawing, Hot, Burning, Aching, Heavy, Tender, Tiring, Exhausting, Punishing, Cruel
Please describe the timing of your pain	Always there
What do you do to ease or relieve your pain?	Bedrest, Massage, Medications, Ice pack, Movement

**Functional Assessment**

Please describe your activities in an average day	Going to school Comments: Mostly can't do many activities anymore. Very frustrating.
---	---

**Working Information**

Current or former occupation	Retired 2020
Are you working now?	No
When was the last time you worked?	2020 Years

**Disability Information**

Are you receiving any kind of disability?	No
---	----

**UPMC Opioid**

In the past 2 weeks, have you taken any opioid pain medication? Some examples are oxycodone, Percocet, hydrocodone, Norco, morphine, tramadol or buprenorphine	No
--	----

**Cannabis Use**

Have you used any cannabis (marijuana, including medical marijuana) over the past six months?	No
---	----

**PROMIS Depression Bank**

In the past 7 days	Often
I felt depressed	
I felt hopeless	Often
I felt worthless	Often
I felt helpless	Always

# Baseline Anxiety Treatment Goals

“Mostly to get rid of my pain and to sleep better and move better”



PROMIS Anxiety Bank	
In the past 7 days	Often
I felt uneasy	
I found it hard to focus on anything other than my anxiety	Often
I felt like I needed help for my anxiety	Sometimes
My worries overwhelmed me	Sometimes
Psychological History Information	
Did you experience chronic pain as a child?	No
Have you ever been psychiatrically hospitalized?	No
Post Traumatic Stress Disorder	
Have you ever experienced a traumatic event	No
Background Information	
How many children do you currently have living at home ?	3 Child/Children
In terms of marital status, are you:	Married
Patient's Treatment Goal	
What is your most important personal goal for your treatment at this clinic ? Some examples are being able to work, walking longer distances, having less pain, or socializing with family/friends	Mostly to get rid of my pain and to sleep better and move better.
Initial Treatment Expectancy	
How much pain relief do you expect to receive from the treatment at this pain clinic	Complete Pain Relief
HEAL Treatment Expectancy	
The next question asks for your thoughts about treatment at this pain clinic. I believe this treatment will help me	Very much
Alcohol and drugs	
Do you drink alcohol?	No
In the past 10 years have you ever tried street drugs?	No
Have you or anyone around you ever felt you had a problem with alcohol or drugs?	No
Have you ever received alcohol or drug treatment?	No
Education	
How far did you go in school? (Select the highest attained)	Associate's Degree
HEAL Attitudes towards Complementary and Alternative Medicine	
CAM is effective	A little bit

# Case Presentation

- Treatments tried prior to medical cannabis referral
  - Pregabalin
  - Tramadol
  - Topical compound cream
  - Hydrocodone (2 pills daily)
- Referred for medical cannabis certification 10/8/24
- Consent and urine toxicology documented
  - 3 month follow up

# Case Presentation

- 1<sup>st</sup> Follow-up shortly after certification 10/31/24
  - Reports using cannabis “gummy” at night with improvement in pain and sleep
  - Hydrocodone taper by more than 50%

# Follow-up CHOIR (apx 1 month post certification)

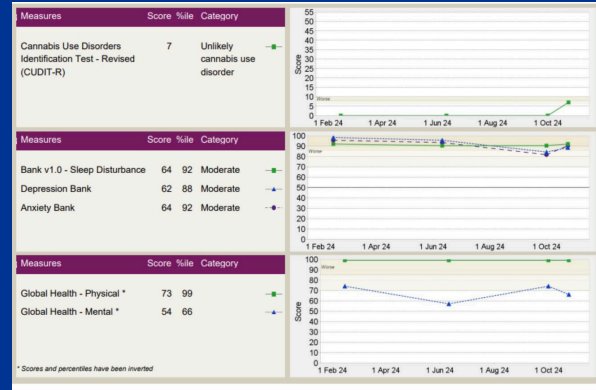
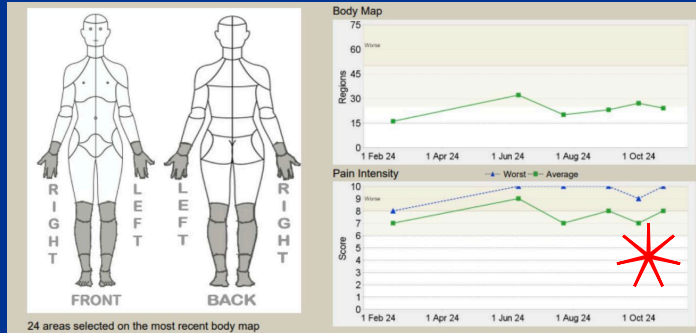

## PROMIS Outcomes Measures

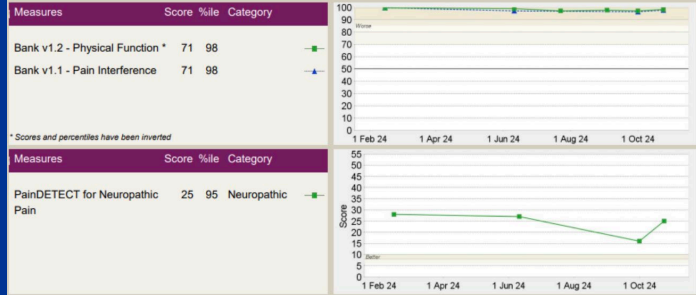

## Impression Of Change

Overall since the start of coming to this pain center, for the treatment you have received or have been prescribed, (such as therapy or a new medication), please rate the impact on your pain and function. Slightly Improved

For the last treatment you have received from this pain center (such as a nerve block or a new medication) please rate the impact on your pain and function. No Change

## PainDETECT for Neuropathic Pain

Score	19-38: Neuropathic. A neuropathic pain component is likely (> 90%).
25	
Radiating pain	No
Pain course	Persistent pain with pain attacks
Burning pain	Strongly
Tingling/Prickling pain	Moderately
Light touching painful	Very strongly
Sudden pain attacks	Moderately
Hot/Cold painful	Moderately

# Follow-up CHOIR (1 month post certification)

PainDETECT for Neuropathic Pain	
Numbness	Strongly
Slight pressure painful	Strongly
Treatment Expectancy FollowUp	
The next question asks for your thoughts about treatment at this pain clinic.	Somewhat
I am confident in this treatment:	
This treatment is right for me:	Somewhat
UPMC Opioid	
In the past 2 weeks, have you taken any opioid pain medication? Some examples are oxycodone, Percocet, hydrocodone, Norco, morphine, tramadol or buprenorphine	Yes
	No misuse reported.
Cannabis Use	
Have you used any cannabis (marijuana, including medical marijuana) over the past six months?	Yes
Cannabis Use Disorders Identification Test - Revised (CUDIT-R)	
Score:	0-7: Unlikely cannabis use disorder
7	
How often do you use cannabis?	2-4 times a month
How many hours were you intoxicated or "stoned" on a typical day when you had been using cannabis?	1 or 2
How often during the past 6 months did you find that you were not able to stop using cannabis once you had started?	Never
How often during the past 6 months did you fail to do what was normally expected from you because of using cannabis?	Never
How often in the past six months have you devoted a great deal of your time to getting, using, or recovering from cannabis?	Never
How often in the past six months have you had a problem with your memory or concentration after using cannabis?	Never
How often do you use cannabis in situations that could be physically hazardous, such as driving, operating machinery, or caring for children?	Never
Have you ever thought about cutting down, or stopping, your use of cannabis?	Yes, during the past six months
UPMC Cannabis Use	
In the past year while you were the driver, did you have a motor vehicle accident (MVA) or a moving traffic violation for which you were pulled over by the police?	No
Have you been certified for Medical Marijuana ?	Yes
When are you likely to use medical marijuana during an average day?	Before Bed
Check all responses that apply.	

PROMIS Depression Bank	
In the past 7 days	Sometimes
I felt depressed	
I felt hopeless	Sometimes
I felt worthless	Sometimes
I felt helpless	Sometimes

PROMIS Anxiety Bank	
In the past 7 days	Rarely
I felt uneasy	
I felt tense	Sometimes
My worries overwhelmed me	Sometimes
I found it hard to focus on anything other than my anxiety	Often
I felt like I needed help for my anxiety	Often

UPMC Closing Comments	
Is there anything else you would like your provider to know ?	Comments: Just that my pain is unbearable in the evenings the most. With the diagnosis I have my life is very hard to manage everyday, but I am grateful for this pain clinic.

# Follow up (3 months after certification)

- Follow-up video visit 2/17/25
  - Continues to use "gummy" only at night and reports sleep "very much improved"
  - Average pain score during daytime 4-5/10
  - Night pain 7-9/10 prompting cannabis use
  - "very much improved"
  - Rare use of hydrocodone (Tapered by over 50%)
  - No new CHOIR data



# Cannabis Efficacy

Research Paper

PAIN 00 (2025) 1–10

# PAIN<sup>®</sup>

## **The comparative effectiveness of medicinal cannabis for chronic pain versus prescription medication treatment**

Ajay D. Wasan<sup>a,\*</sup>, Brian O'Connell<sup>a</sup>, Rebecca DeSensi<sup>a</sup>, Cheryl Bernstein<sup>a</sup>, Elizabeth Pickle<sup>a</sup>, Michael Zemaitis<sup>b</sup>, Oren Levy<sup>c</sup>, Jong-Hyeon Jeong<sup>d</sup>, Gregory F. Cooper<sup>e</sup>, Antoine Douaihy<sup>f</sup>

# Inclusion

- Patients certified for medical marijuana from 2018 to 2023
  - Baseline patient-reported outcomes data at the time of the certification visit and 3-month follow-up outcomes data.
  - 6 month follow up as well
- Control group
  - Prescribed a new medication treatment for chronic pain (nonopioid or opioid) during the same timeframe and were not certified for medical marijuana

# Study Objectives

- Efficacy of **medical cannabis** for pain versus other **medications**
- Used Patients Outcomes Repository for Treatment (PORT)
- CHOIR data
  - pain intensity and other measures
  - Functional improvement
  - Patient impression of change

# Study Design

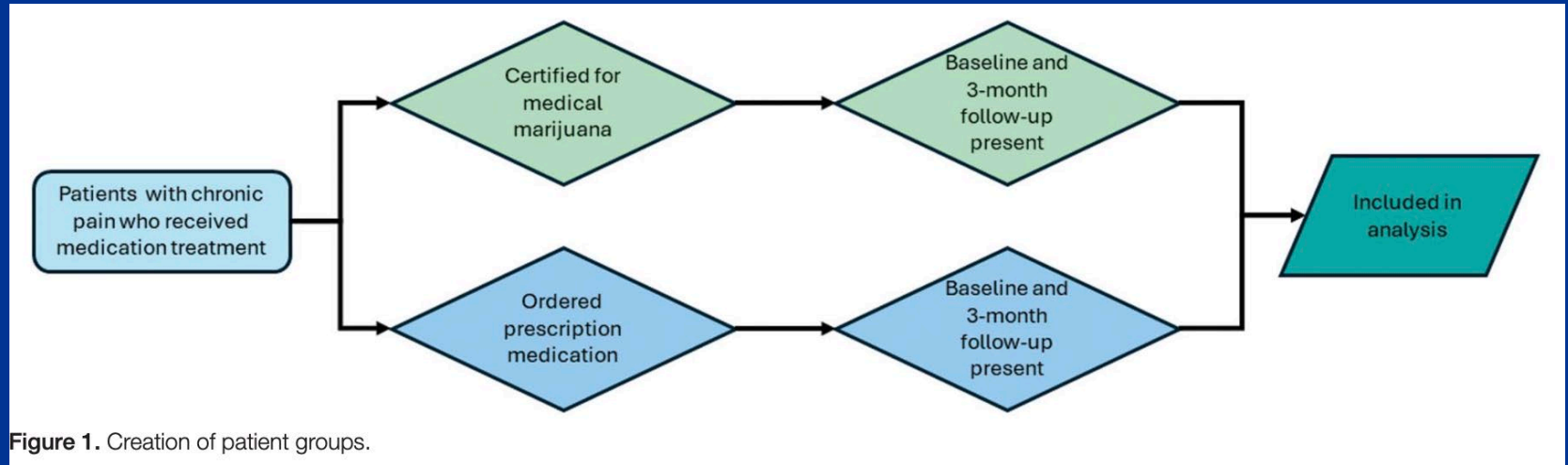

# Responder Rates

## Cannabis vs. Other Medication

- Significant reduction in pain
- Clinically significant improvement in function
- Significant impression of change
- Combination of above

# Outcomes

A significantly higher percentage of patients certified for medical cannabis responded to treatment compared to control group.

**Table 2**  
**Responder rates between groups.**

Variable	Marijuana (N = 440)	Control (N = 8114)
Treatment responders (3 mo)		
Pain intensity average, physical function, or impression of change for treatment responder (raw count [%])	170 (38.6%)	2833 (34.9%)
Pain intensity average responder	43 (9.8%)	1052 (13.0%)*
Physical function responder	73 (16.6%)	1453 (17.9%)
Impression of change for treatment responder	95 (21.6%)	813 (10.0%)*
More than 1 domain of response	39 (8.9%)	472 (5.82%)
Treatment responders (6 mo)		
Pain intensity average, physical function, or impression of change for treatment responder (raw count [%])	167 (38.0%)	—
Pain intensity average responder	51 (11.6%)	—
Physical function responder	71 (16.1%)	—
Impression of change for treatment responder	79 (18.0%)	—
More than 1 domain of response	32 (7.3%)	—

# Outcomes Medical Cannabis Group

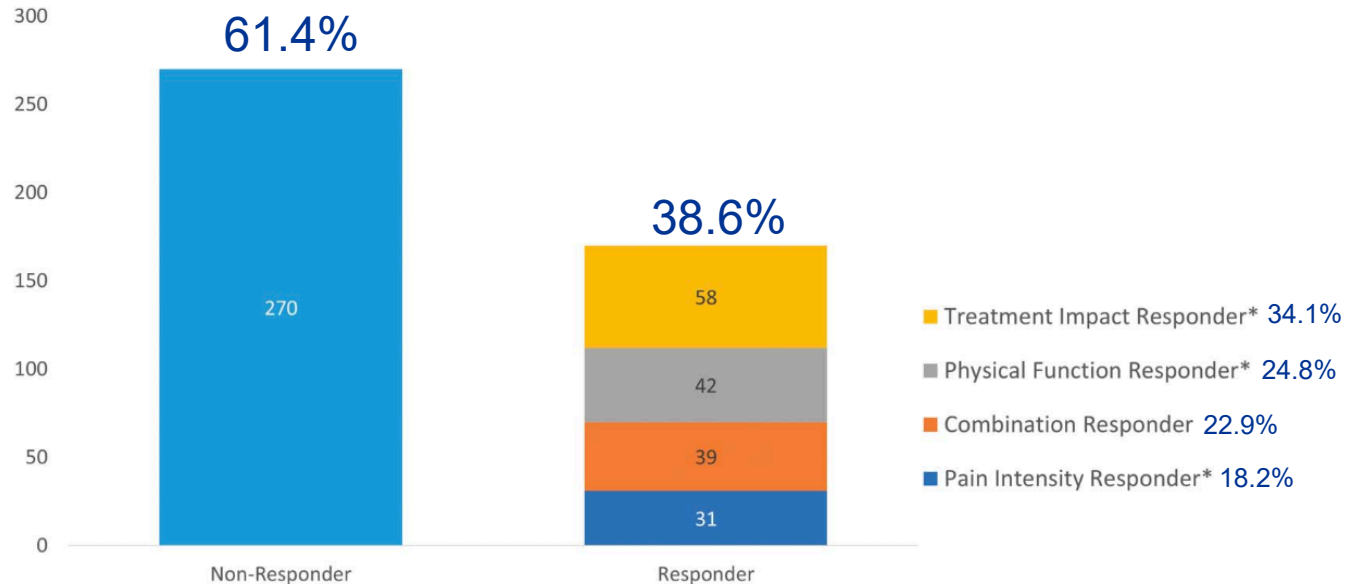

**Figure 2.** Three-month medical marijuana responder status for pain intensity average, physical function, and treatment impact. \*Indicates that patients ONLY responded in this domain.

# Medical Cannabis and Opioid Taper

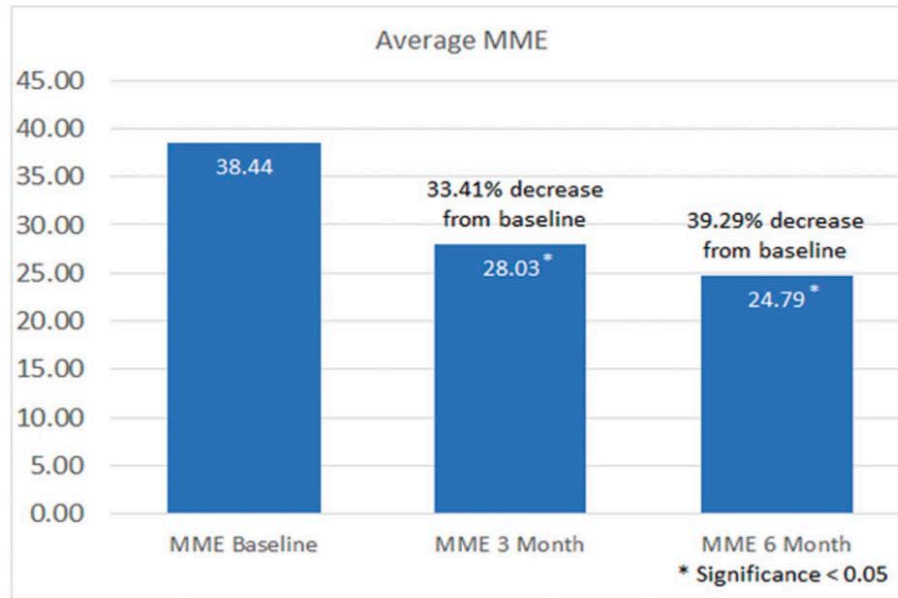

Figure 3. Changes in morphine milligram equivalents (MME), N = 157.



# Study Conclusions

- Medical cannabis more effective than conventional medications
  - odds of responding 2.6 times higher in the medical marijuana group
  - response in the control group (34.9%) was very similar to the marijuana group (38.6%) at 3 months
- 9% in the marijuana group responded in more than one domain
- 39% reduction in prescribed MMEs over 6 months

# Risks of Medical Cannabis Use

# **Problematic Medical Cannabis Use in Patients with Chronic Pain**

Cheryl D. Bernstein, Benedict J. Alter, Rebecca S.  
DeSensi Brian O'Connell, Maya Maurer, Ajay D. Wasan.

# Cannabis Use Disorder

- Estimated to affect 1/3 adults using cannabis<sup>1</sup>
- Problematic use of cannabis defined by two of following<sup>2</sup>
  - Taken in larger amounts than needed
  - Social or interpersonal problems
  - Inability to stop
  - Spending a great deal of time using
  - Cravings
  - Failure to fulfill obligations
  - Use in hazardous situations
  - Use despite physical or psychological harm
  - Tolerance
  - Withdrawal

1. *JAMA Psychiatry*. 2015;72(12):1235-1242

3. American Psychiatric Association. (2022). *Diagnostic and statistical manual of mental disorders* (5th ed., text rev.)

# Study Aims

- Identify problematic medical cannabis use in patients with chronic pain
- Identify patient factors that predict problematic use
- Study patterns of medical cannabis use
  - What form are patients using medical cannabis
  - When are patients typically using medical cannabis

# Study Design

220 Patients—Routine Follow-up Visits

Certified for Medical Cannabis for Chronic Pain > 6 months

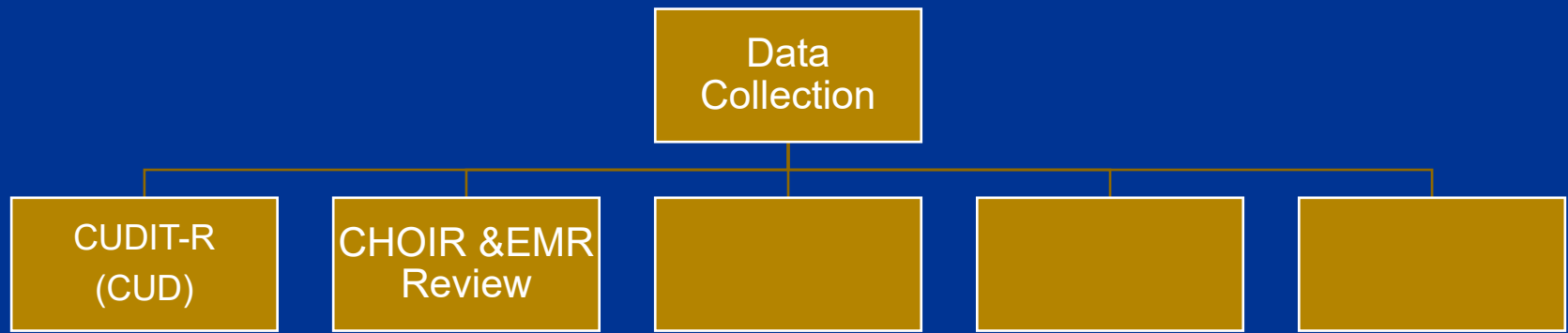

### Cannabis Use Disorder Identification Test—Revised (CUDIT-R)<sup>1</sup>

- Screen for cannabis use disorder (recreational use)
- Self reported 8-item questionnaire (0-4 points/question)
  - Score  $\geq 8$  indicates problematic use
  - Score  $\geq 12$  indicates CUD
- Assessment of:
  - Cannabis consumption
  - Abuse
  - Dependence
  - Psychological impact

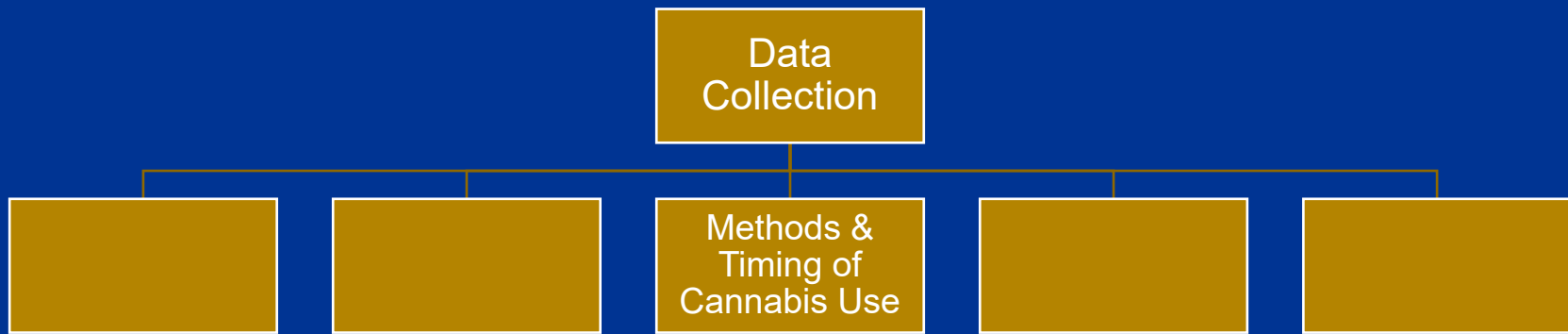

- **Method of cannabis use**

- Predominantly inhaled (smoking or vaping)
- Non-inhaled (tincture, pill, topical, mixed)
- Topical only

- **Timing of cannabis use**

- “When are you most likely to use cannabis on a typical day”

Morning  
Afternoon  
Evening  
Before bed  
Middle of night

} Indicate any that apply



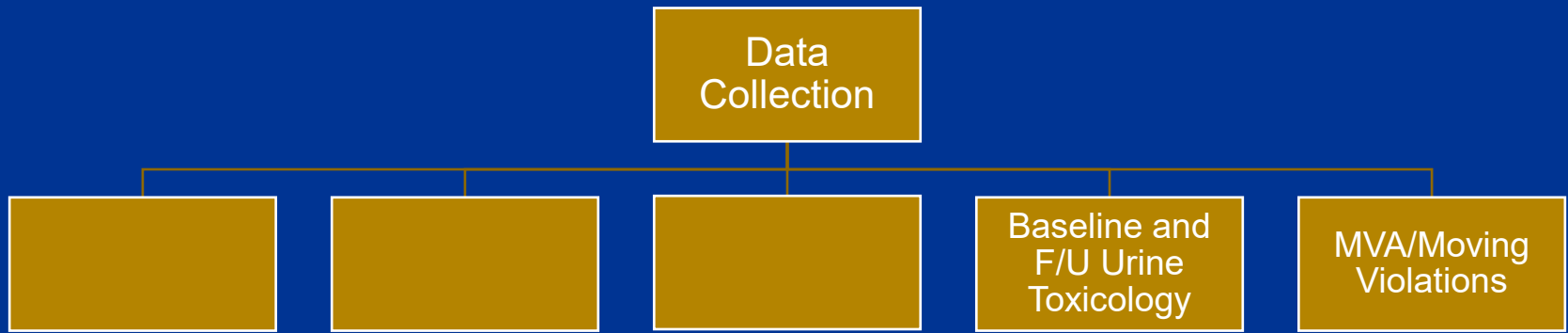

- Reviewed electronic medical records for baseline and follow up toxicology screen
  - Division policy to have baseline toxicology prior to certification
  - Follow-up toxicology at least once yearly
- Patients who drive were questioned about MVA or moving violation in past year

# CUDIT-R Scores (n=220)

- 76% CUDIT-R scores <8
  - 50% scored  $\leq 4$
- 24% patients  $\geq 8$ 
  - Only 3 patients scored  $\geq 12$  (possible CUD)

CUDIT-R Scores 8-11 possible hazardous use $\geq 12$ possible CUD	n (%)
CUDIT $\leq 4$	111 (50)
CUDIT 5-7	57 (25.9)
CUDIT $\geq 8$ (possible hazardous use)	52 (23.6)

# **Patient Factors That Predict Problematic Use: High CUDIT-R Scores**

# Cannabis Use Before Certification and CUDIT-R Scores

- Patients using cannabis prior to certification (baseline positive THC tox screen) had higher CUDIT-R scores ( $P < 0.001$ ).

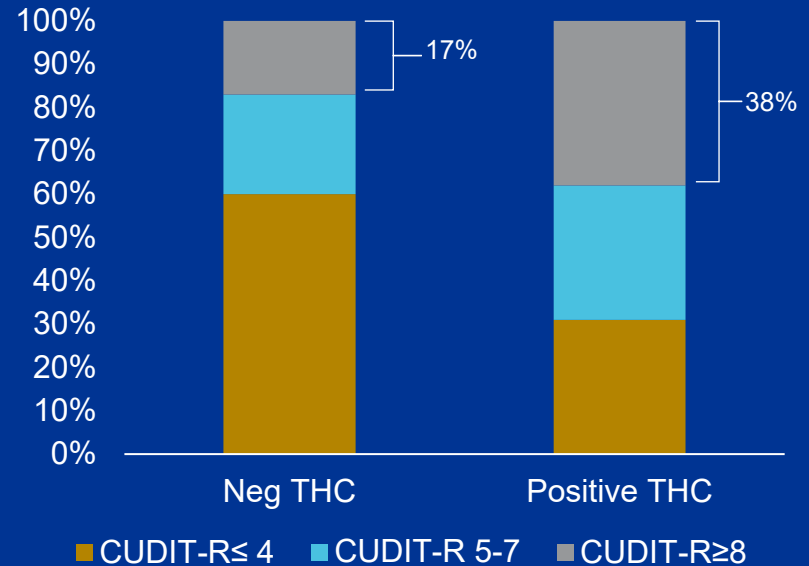

# Inhaled Cannabis Use and CUDIT-R Scores

- Patients using inhaled cannabis had higher CUDIT-R scores ( $P < 0.001$ ).

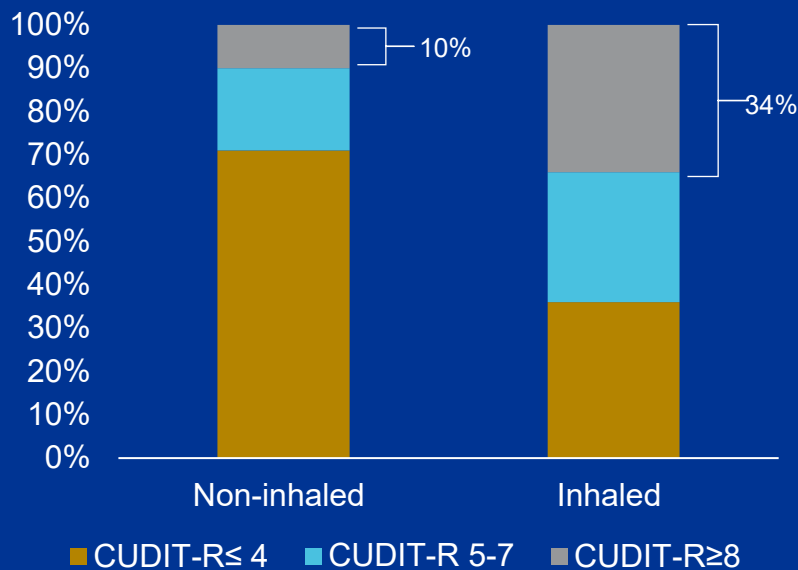

# Several Factors Predicted Higher CUDIT-R Scores

- Linear Regression Models
- Multiple factors predicted higher CUDIT-R scores ( $p < .05$ )
  - Young age
  - Poor global mental health (CHOIR survey)
  - Inhaled use
  - Positive baseline THC (use prior to medical cannabis certification)

# Patterns of Use

- 53% of patients used inhaled forms of medical cannabis
  - Patients advised to avoid inhaled use at initial and follow up visits
- Over half of patients limited use to evening or later

Method of Use (n=129)	n (%)
Non-inhaled	60 (46.5%)
Inhaled	69 (53.5%)

Timing of Use (n 218)	n (%)
Evening Only	113 (52%)

# Baseline and Follow-up Toxicology Screens

- 31% patients had baseline drug screens positive for THC
  - Patients using cannabis prior to medical cannabis certification
- Almost all patients had consistent follow-up drug screens

Baseline Tox Screen (n=196)	n (%)
Negative for THC	135 (68.9%)
Positive for THC	61 (31.1%)

Follow-up Tox Screens (n 214)	n (%)
Consistent	210 (98.1%)
Inconsistent	4 (1.9)



# Safety Conclusions

- Problematic use (CUDIT-R  $\geq 8$ ) in 24% of patients
  - Some patient factors increase risk of problematic use
- Over half of medical cannabis patients limited cannabis to evening or later
- Follow up urine toxicology was consistent

# Medical Cannabis Summary

- Effective option for chronic pain
  - May be more effective than other medications
  - Recommend as part of multimodal plan
- Recommend non inhaled options
  - Low dose ingestible forms and pills (5-10mg)THC
  - Tincture THC:CBD 1:1 option
  - Topical forms (salves and patches)
- Recommend no driving 6-8 hours after use
- Further studies on safety and efficacy needed

# A Joint Effort

Rebecca DeSensi, MS

Brian O'Connell, MS

Maya Maurer, MS

Benedict Alter, MD, PhD

Ajay D. Wasan, MD, MSc



# DYSLIPIDEMIA

UPMC Family Medicine Refresher Course  
Alexandria Taylor, PharmD, BCPS

*Clinical Pharmacist Senior, Family Medicine*

*Director, UPMC St. Margaret PGY1 Pharmacy Residency Program*

*Faculty, UPMC St. Margaret Family Medicine*

# OBJECTIVES



**Identify** the target LDL-C levels for different risk categories according to the latest guidelines



**Outline** the stepwise approach to initiating and adjusting lipid-lowering therapy based on patient response and tolerance



**Analyze** recent clinical trial data on the efficacy and safety of novel non-statin therapies in reducing cardiovascular events



# ABBREVIATIONS

ABI- ankle-brachial index

ACS- acute coronary syndrome

ASCVD- atherosclerotic cardiovascular disease

BMI- body mass index

CABG- coronary artery bypass

CACS- coronary artery calcium scoring

CAS- coronary artery disease

CKD- chronic kidney disease

CVD- cardiovascular disease

DBP- diastolic blood pressure

DM- Diabetes mellitus

FH- familial hyperlipidemia

HF- Heart Failure

HTN- hypertension

MI- myocardial infarction

PAD- peripheral arterial disease

PCI- percutaneous coronary intervention

SBP- systolic blood pressure

UA- unstable angina

UACR- urine albumin-to-creatinine ratio



# LIPID GOALS

# When to Screen

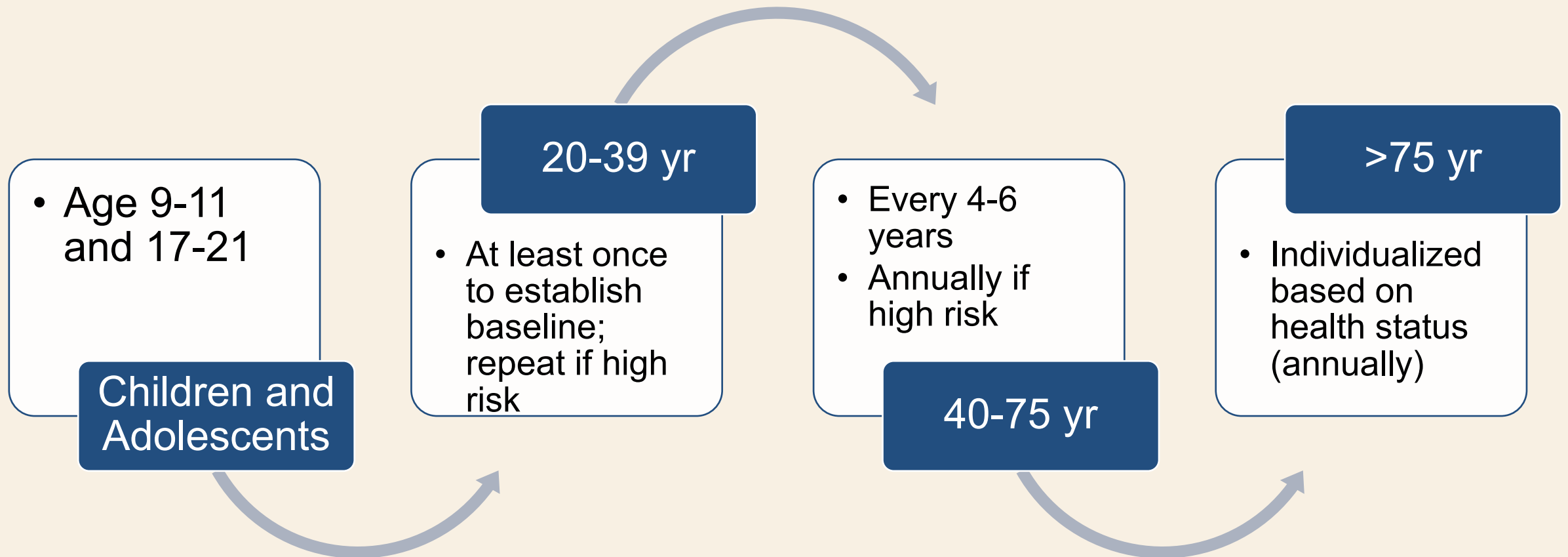





## WHAT LDL GOAL DO YOU TARGET?

Scan the QR code to answer!



Join at [menti.com](https://menti.com) | use code **7869 0614**



Choose a slide to present

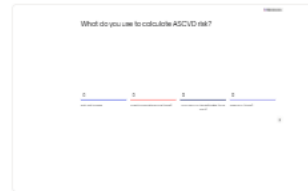
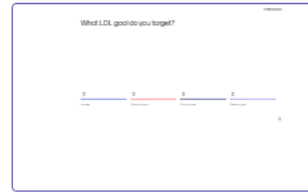

# What LDL goal do you target?

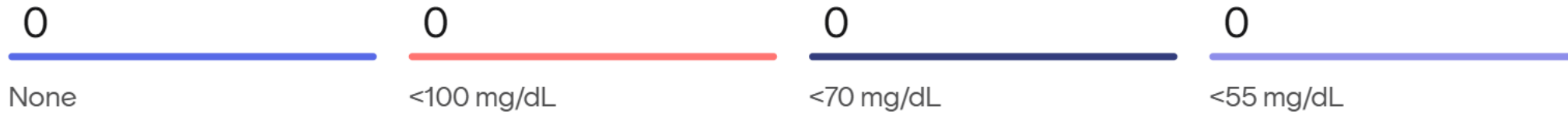

# LDL-C TARGETS

<b>Guideline</b>	<b>Desired LDL-C</b>
AHA/ACC Blood Cholesterol Guideline (2018)	<b>Primary prevention:</b> ≥30%-50% LDL-C lowering <b>Secondary prevention:</b> ≥50% LDL-C lowering with high intensity statin and consider additional Rx if LDL-C ≥70 mg/dL in patient at very high risk

# LDL-C TARGETS

Guideline	Desired LDL-C
AHA/ACC Blood Cholesterol Guideline (2018)	<b>Primary prevention:</b> ≥30%-50% LDL-C lowering <b>Secondary prevention:</b> ≥50% LDL-C lowering with high intensity statin and consider additional Rx if LDL-C ≥70 mg/dL in patient at very high risk
AACE/ACE (2020)	<b>Primary prevention:</b> <70 (very high risk), <100 (moderate or high risk), or <130 mg/dL (low risk) <b>Secondary prevention:</b> <55 (extreme risk) or <70 mg/dL (very high risk)

# LDL-C TARGETS

Guideline	Desired LDL-C
AHA/ACC Blood Cholesterol Guideline (2018)	<p><b>Primary prevention:</b>            ≥30%-50% LDL-C lowering</p> <p><b>Secondary prevention:</b>            ≥50% LDL-C lowering with high intensity statin and consider additional Rx if LDL-C ≥70 mg/dL in patient at very high risk</p>
AACE/ACE (2020)	<p><b>Primary prevention:</b>            &lt;70 (very high risk), &lt;100 (moderate or high risk), or &lt;130 mg/dL (low risk)</p> <p><b>Secondary prevention:</b>            &lt;55 (extreme risk) or &lt;70 mg/dL (very high risk)</p>
ACC ECDP on LDL-C Lowering (2022)	<p><b>Primary prevention:</b>            ≥30%-50% LDL-C lowering, consider additional Rx when LDL-C exceeds &lt;70, &lt;100, or &lt;130 mg/dL based on risk level/comorbidity</p> <p><b>Secondary prevention:</b>            ≥50% LDL-C lowering with high intensity statin and additional Rx to target &lt;55 (very high risk) or &lt;70 mg/dL (not at very high risk)</p>

# AHA/ACC BLOOD CHOLESTEROL GUIDELINE (2018): *VERY HIGH RISK*

## Major ASCVD Events

- Recent ACS (past 12 mo)
- Hx of MI
- Hx of ischemic stroke
- Symptomatic PAD

## High-Risk Conditions

- Age  $\geq$  65 yr
- Heterozygous FH
- Hx of CABG or PCI
- DM
- HTN
- CKD
- Current smoking
- Hx of congestion HF
- Persistently elevated LDL-C ( $\geq$  100 mg/dL) despite max statin + ezetimibe

# AHA/ACC BLOOD CHOLESTEROL GUIDELINE (2018): *VERY HIGH RISK*

## Major ASCVD Events

- Recent ACS (past 12 mo)
- Hx of MI

## High-Risk Conditions

- Age  $\geq$  65 yr
- Heterozygous FH

Very High Risk: Meets 1 major ASCVD event + several high-risk conditions OR 2+ major ASCVD events

- Current smoking
- Hx of congestion HF
- Persistently elevated LDL-C ( $\geq$  100 mg/dL) despite max statin + ezetimibe

# AACE/ACE (2020): RISK DEFINITIONS

Risk Category	Risk Factors	Treatment Goals (mg/dL)		
		LDL-C	Non-HDL-C	Apo B
<b>Extreme risk</b>	<ul style="list-style-type: none"> <li>Progressive ASCVD including UA</li> <li>Established clinical ASCVD + DM or CKD <math>\geq 3</math> or FH</li> <li>Hx of premature ASCVD (&lt;55yr male, &lt;65 yr female)</li> </ul>	<55	<80	<70
<b>Very high risk</b>	<ul style="list-style-type: none"> <li>Established clinical ASCVD, or recent hospitalization (for ACS, carotid, or peripheral vascular disease), or 10-year risk &gt;20%</li> <li>DM with <math>\geq 1</math> risk(factors)</li> <li>CKD <math>\geq 3</math> w/ albuminuria</li> <li>FH</li> </ul>	<70	<100	<80



# AACE/ACE (2020): RISK DEFINITIONS

Risk Category	Risk Factors	Treatment Goals (mg/dL)		
		LDL-C	Non-HDL-C	Apo B
<b>High risk</b>	<ul style="list-style-type: none"> <li>• <math>\geq 2</math> risk factors &amp; 10-yr risk 10-20%</li> <li>• DM or CKD <math>\geq 3</math> w/ no other risk factors</li> </ul>	<100	<130	<90
<b>Moderate risk</b>	<ul style="list-style-type: none"> <li>• &lt;2 risk factors &amp; 10-yr risk &lt;10%</li> </ul>	<100	<130	<90
<b>Low risk</b>	<ul style="list-style-type: none"> <li>• No risk factors</li> </ul>	<130	<160	NR

**Risk factors:** advancing age, elevated non HDL-C, elevated LDL-C, low HDL-C, DM, HTN, CKD, smoking, family hx of ASCVD

# ACC ECDP ON LDL-C LOWERING (2022): RISK DEFINITIONS

## Major ASCVD Events

- Recent ACS (past 12 mo)
- Hx of MI
- Hx of ischemic stroke

Very High Risk

severe

Same as AHA/ACC Blood Cholesterol Guideline (2018)

## High-Risk Conditions

- Age  $> 75$  years
- Hx of congestive HF
- Persistently elevated LDL-C ( $\geq 100$  mg/dL) despite max statin + ezetimibe



# WHAT DO YOU USE TO CALCULATE ASCVD RISK?

Scan the QR code to answer!



Join at [menti.com](https://menti.com) | use code 7869 0614



Menti

Dyslipidemia FMRC



Choose a slide to present

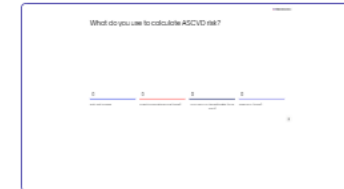

# What do you use to calculate ASCVD risk?

0

Epic dot phrase

0

Framingham Risk Score (2008)

0

ACC ASCVD risk estimator (PCE 2013)

0

PREVENT (2024)



# CALCULATORS

- **Framingham (2008)**

- Age (30-79 yo), sex, smoking status, total cholesterol, HDL-C, SBP, BP treated

- **ACC ASCVD Risk Estimator (PCE 2013)**

- Age (**20**-79 yo), sex, **race**, smoking status, **diabetes**, total cholesterol, HDL-C, SBP, **DBP**, BP treated



- **PREVENT (2024)**

- Age (30-79 yo), sex, smoking status, **diabetes**, total cholesterol, HDL-C, SBP, BP treated, **BMI, eGFR, lipid-lowering medication**
- *Optional: UACR, A1C, zip code (social deprivation index)*

D'Agostino RB Sr, et al. *Circulation*. 2008;117(6):743-753.

Goff DC Jr, et al. 2014 Jun 24;129(25 Suppl 2):S74-5]. *Circulation*. 2014;129(25 Suppl 2):S49-S73.

Khan SS, et al. *Circulation*. 2024 Mar 12;149(11):e956.

# HEALTH DISPARITIES ACROSS ASCVD RISK

- ACC/AHA 2013 ASCVD risk estimator race can have as much as 12% difference
  - Consider alternative risk factors
- Social determinants of health
- Undiagnosed or untreated comorbidities
- Delayed recognition of ACS events



An abstract geometric design on the left side of the slide. It features a grid of colored squares: a bright pink square at the top left, a grey square below it, a dark purple square at the bottom left, and a blue square at the bottom. The pink square contains a white semi-circle with concentric white lines. The grey square contains a white semi-circle with concentric white lines. The dark purple square contains a white semi-circle with concentric white lines. The blue square contains a white semi-circle with concentric white lines. A white horizontal line with a white circle at its right end extends from the top left towards the center. The background is a solid magenta color.

# TREATMENT APPROACH

# AHA/ACC BLOOD CHOLESTEROL GUIDELINE (2018): TREATMENT RECOMMENDATIONS

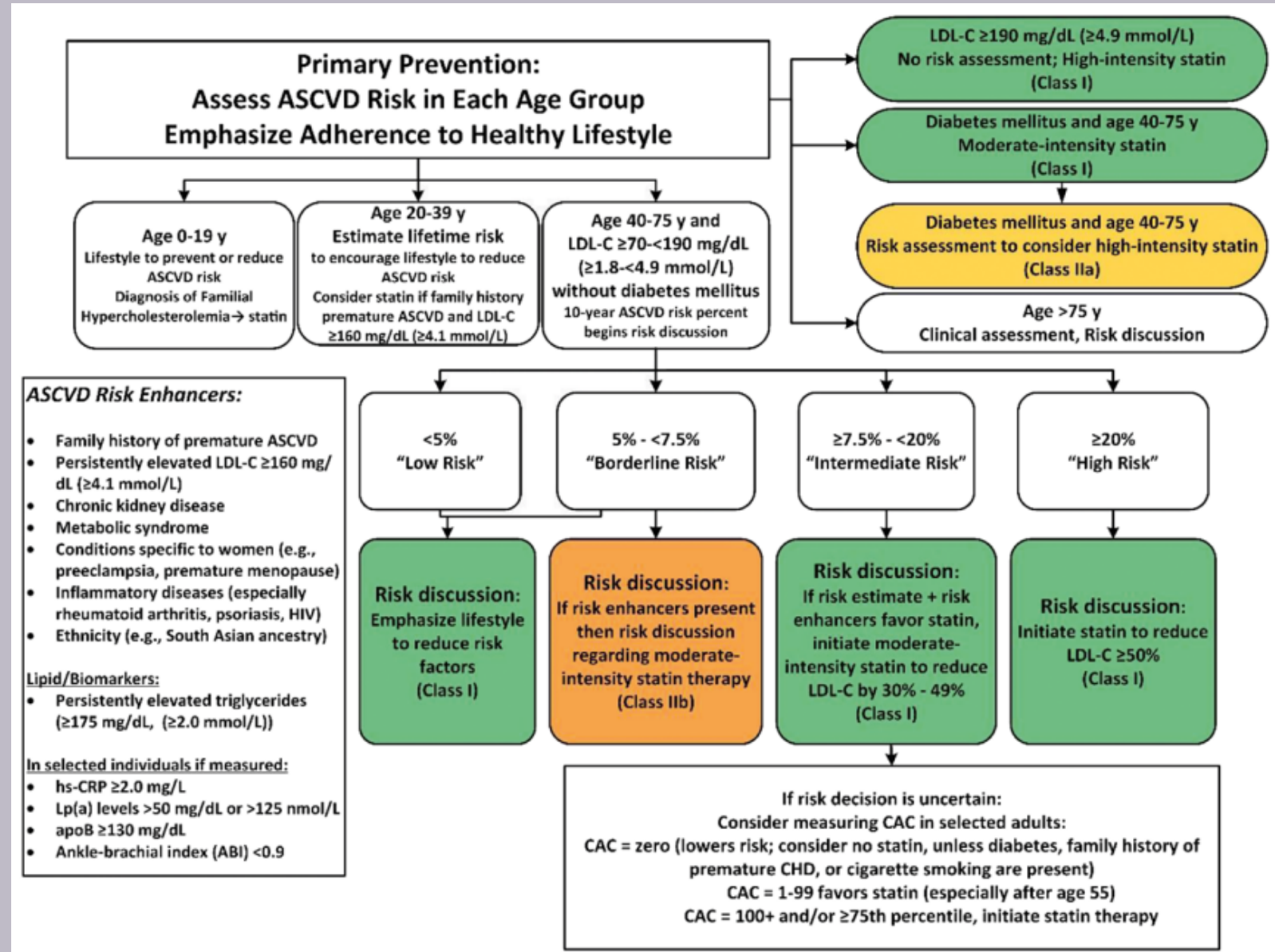



# AHA/ACC BLOOD CHOLESTEROL GUIDELINE (2018): TREATMENT RECOMMENDATIONS

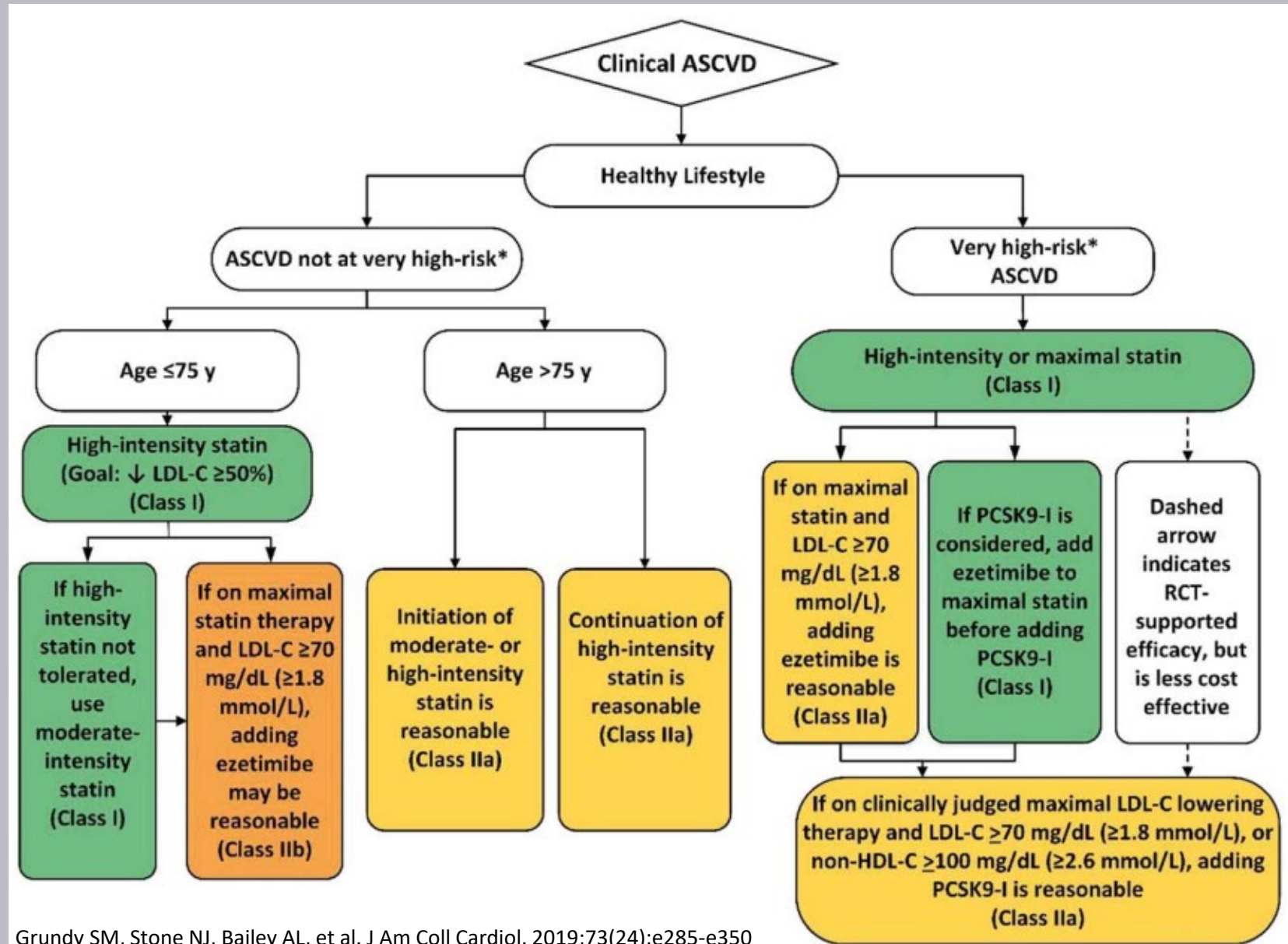

# AHA/ACC BLOOD CHOLESTEROL GUIDELINE (2018): TREATMENT RECOMMENDATIONS

<p><b>Clinical ASCVD (ie CAD, stroke, PAD, etc)</b></p>	<p><b>ASCVD not at high risk (see below)</b>          ≤ 75 yo: high-intensity statin          &gt; 75 yo: moderate- or high-intensity statin  <b>ASCVD at high risk</b>          High-intensity or maximal tolerated statin          If on maximal tolerated statin &amp; LDL ≥ 70 mg/dL, can add ezetimibe</p>	
<p><b>Patients 20-75 yo with LDL ≥ 190 mg/dL</b></p>	<p>Maximal tolerated statin          If on maximal tolerated statin &amp; LDL ≥ 100 mg/dL, can add ezetimibe</p>	
<p><b>Patients 40-75 yo with diabetes</b></p>	<p>Any patient in this group          Moderate-intensity statin          Additional risk factors*          High-intensity statin</p>	<p><b>*PMH T1DM ≥ 20 yrs, PMH T2DM ≥ 10 yrs, albuminuria ≥ 30 mcg albumin/mg creatinine; eGFR &lt; 60 mL/min/1.73m<sup>2</sup>; retinopathy; neuropathy; ABI &lt; 0.9</b></p>
<p><b>Patients 40-75 yo with LDL 70-190 mg/dL</b></p>	<p>Based on 10-year ASCVD risk score          &lt; 5% Lifestyle changes          5-7.49% Lifestyle changes &amp; potential moderate-intensity statin          7.5-19.9% Moderate-intensity statin          ≥ 20% High-intensity statin</p>	

# AACE/ACE (2020): TREATMENT RECOMMENDATIONS

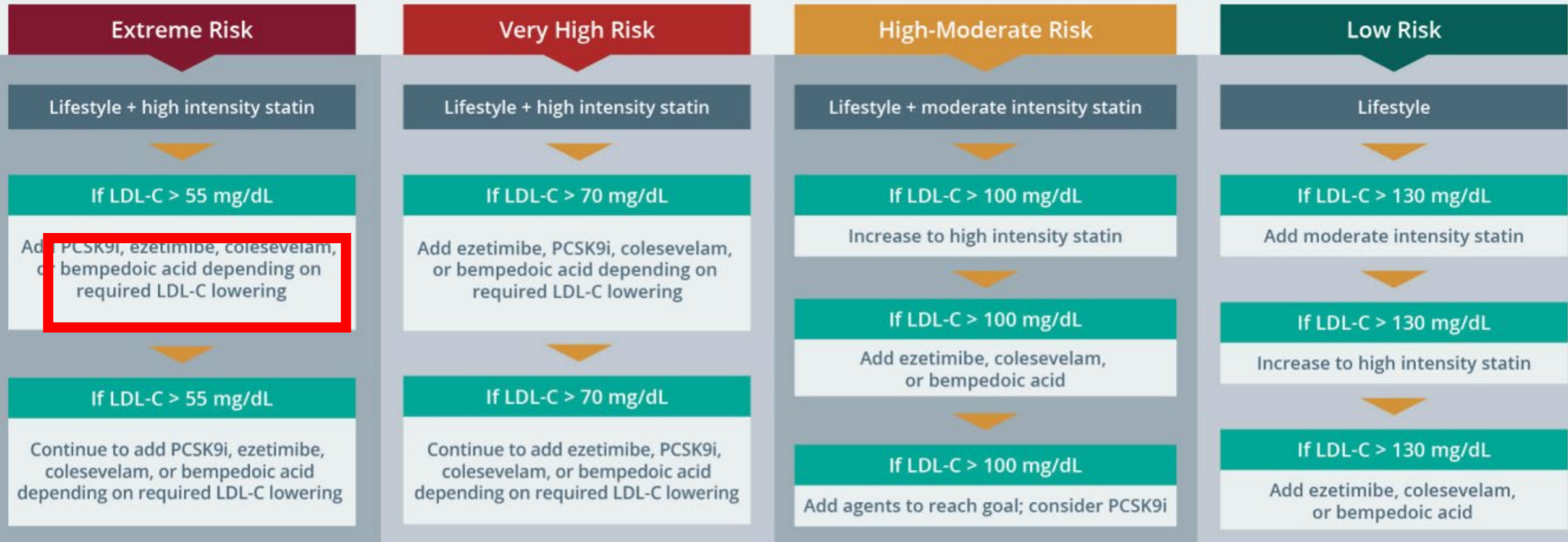

# ACC ECDP ON LDL-C LOWERING (2022): TREATMENT RECOMMENDATIONS

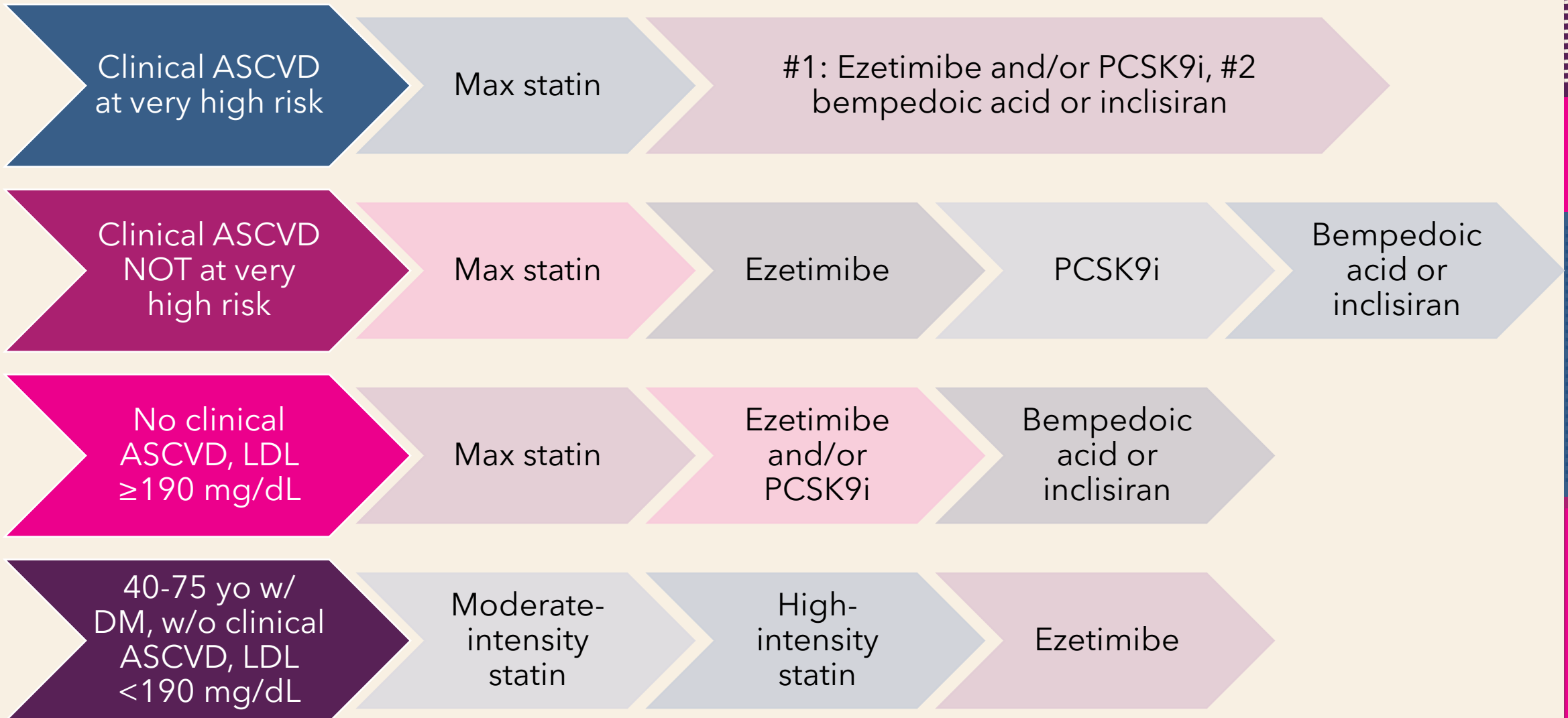

# STATIN INTOLERANCE

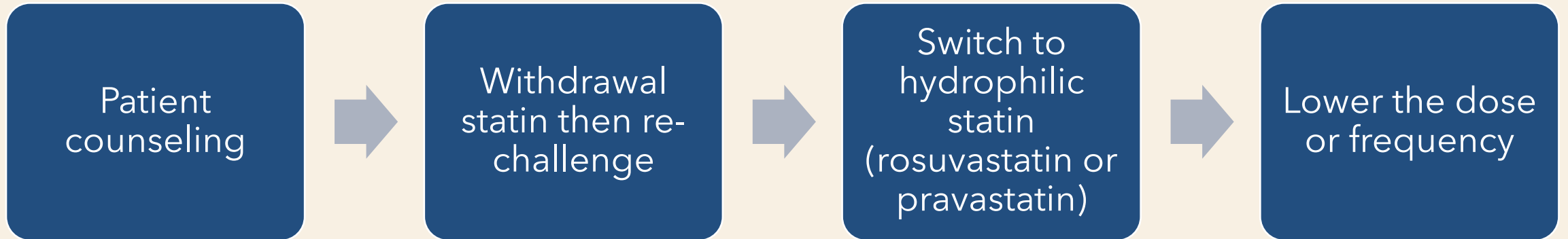

<b>Adverse Effect</b>	<b>Exclusionary ICD-10 Code</b>
Myalgia	M79.1, M79.10, M79.11, M79.12, M79.18
Myopathy	G72.0, G72.2, G72.89, G72.9
Myositis	M60.80, M60.9
Rhabdomyolysis	M62.82
Other	T46.6X5A

An abstract geometric design on the left side of the slide. It features a grid of colored squares: a bright pink square at the top left, a grey square below it, a dark purple square at the bottom left, and a blue square at the bottom. The pink square contains a pattern of concentric white semi-circles. The grey square contains a pattern of concentric white semi-circles. The dark purple square contains a pattern of concentric white semi-circles. The blue square contains a pattern of concentric white semi-circles. A white horizontal line with a white circle at its end extends from the top left towards the center. The background is a solid magenta color.

# NEW TREATMENT OPTIONS



**Which of the following medications do you currently prescribe for patients?**

Scan the QR code to answer!



Join at [menti.com](https://menti.com) | use code **7869 0614**



Menti

Dyslipidemia FMRC



Which of the following medications do you currently prescribe for patients? Select all that apply.

Choose a slide to present



0

Statins

0

Ezetimibe

0

Bile acid sequestrants

0

PCSK9i

0

Bempedoic acid

0

Inclisiran





# BEMPEDOIC ACID

<b>Administration</b>	180 mg 1 tablet by mouth daily
<b>Medication Class</b>	Adenosine Triphosphate-Citrate Lyase (ACL) Inhibitor
<b>Warnings/precautions</b>	Hyperuricemia/gout, hx of tendon rupture
<b>Common side effects</b>	Bronchitis, anemia, elevated liver enzymes, back pain
<b>Mean LDL-C reduction</b>	17-18%
<b>Cost Effectiveness</b>	Incremental cost-effectiveness ratio of \$33,893 per QALY gained & \$28,827 per year of life saved



# CLEAR-OUTCOMES (2023)

## Population

- 13,970 patients
- Age 18-85 yr
- LDL-C  $\geq$  100 mg/dL & 1 of 2 criteria for increased CVD risk (previous CVD event or clinical features placing at high risk of CVD event)

## Results

- Primary outcome: composite of death from CVD causes, nonfatal MI, nonfatal stroke, or coronary revascularization
- 11.7% vs 13.3% [HR 0.87; 95% CI 0.79-0.96]
- **NNT 43 patients for 3+ yr**

# INCLISIRAN



<b>Administration</b>	284 mg as a single subq injection, again at 3 months, and then every 6 months by health care provider
<b>Medication Class</b>	Small Interfering Ribonucleic Acid (siRNA)
<b>Warnings/precautions</b>	None
<b>Common side effects</b>	Injection site reaction, arthralgia, urinary tract infection, diarrhea, bronchitis
<b>Mean LDL-C reduction</b>	48-52%

# INCLISIRAN



## Administration

284 mg as a single subq injection, again at 3 months, and then every 6 months by

CV outcomes trials not yet completed. ORION-4 currently in progress with estimated completion in 2026. VICTORION-2P currently in progress with estimated completion in 2027

**Mean LDL-C reduction** 48-52%

# PCSK9i: Evolocumab & Alirocumab

## Administration

**Evolocumab:** 140 mg subq q2 weeks or 420 mg subq q1 month

**Alirocumab:** 75 mg subq q2 weeks or 300 mg subq q1 month (can inc to 150 mg subq q2 weeks)



## Warnings/precautions

Hypersensitivity reactions

## Common side effects

Nasopharyngitis, injection site reactions, influenza, back pain

## Mean LDL-C reduction

45-65%

## Cost Effectiveness

Cost-effectiveness threshold \$150,000

**Incremental Cost-Effectiveness Ratio** between \$197,707 and \$625,555, depending on the model used



# FOURIER (2017) EVOLOCUMAB

## Population

- 24,081 patients
- Age 40-85 yr
- ASCVD + 1 major or 2 minor risk factors & LDL-C  $\geq$  70 mg/dL

## Results

- Primary outcome: composite of death from CVD causes, MI, stroke, hospitalizations for UA or coronary revascularization)
- 5.9% vs 7.4% [HR 0.80; 95% CI 0.73-0.88]
- **NNT 74 patients for 2 yr to prevent a CVD death, MI , or stroke**

# ODYSSEY OUTCOMES(2018)

## ALIROCUMAB

### Population

- 18,924 patients
- Age 40+ yr
- ACS hospitalization 1-12 months before randomization; LDL-C  $\geq$  70 mg/dL, non-HDL-C  $\geq$  100 mg/dL, or ApoB  $\geq$  80 mg/dL

### Results

- Primary outcome: composite of death from CVD causes, nonfatal MI, fatal/nonfatal stroke, or hospitalization for UA
- 9.5% vs 11.1% [HR 0.78; 95% CI 0.68-0.91]
- **NNT 43 (age 45 yr), 26 (age 75 yr), 12 (age 85 yr) for 3 yrs**



# NOVEL LP(A) THERAPIES

- **Antisense-Oligonucleotides (ASOs)**
  - Pelacarsen phase 3 trial Lp(a)-HORIZON anticipated May 2025
- **Small-Interfering RNA Agents (siRNAs)**
  - Lepodisiran phase 2 ALPACA trial
  - Olpasiran phase 3 OCEAN(a) trial anticipated late 2026
  - Zerlasiran phase 1 APOLLO trial, phase 2 ALPACAR-360 trial Dec 2024



# LIFESTYLE MEDICINE

- **Diet**

- Whole-food, plant-based
- Mediterranean
- DASH

- **Physical activity**

- $\geq 3$  times/wk
- 150 min/wk moderate-intensity or 75 min/wk high-intensity
- Resistance training  $\geq 2$  times/wk

- **Familyheart.org**

- Risk reduction strategies
- Support and advocacy
- Educational webinars and events
- Printable materials
- Nutrition guides
- Genetic testing options

This Photo by Unknown Author is licensed under [CC BY](https://creativecommons.org/licenses/by/4.0/)

# TAKE AWAY POINTS

Identify the target LDL-C levels for different risk categories according to the latest guidelines

- Different targets based on primary vs secondary and risk
- Secondary prevention <55 (extreme risk) or <70 mg/dL (very high risk)

Outline the stepwise approach to initiating and adjusting lipid-lowering therapy based on patient response and tolerance

- Max statin → ezetimibe → PCSK9i → bempedoic acid (oral) or inclisiran

Analyze recent clinical trial data on the efficacy and safety of novel non-statin therapies in reducing cardiovascular events

- CV benefits data with PCSK9i and bempedoic acid

# REFERENCES

- Grundy SM, Stone NJ, Bailey AL, et al. 2018 AHA/ACC/AACVPR/AAPA/ABC/ACPM/ADA/AGS/APhA/ASPC/NLA/PCNA Guideline on the Management of Blood Cholesterol: A Report of the American College of Cardiology/American Heart Association Task Force on Clinical Practice Guidelines [published correction appears in J Am Coll Cardiol. 2019 Jun 25;73(24):3237-3241]. J Am Coll Cardiol. 2019;73(24):e285-e350. doi:10.1016/j.jacc.2018.11.003
- Handelsman Y, Jellinger PS, Guerin CK, et al. Consensus Statement by the American Association of Clinical Endocrinologists and American College of Endocrinology on the Management of Dyslipidemia and Prevention of Cardiovascular Disease Algorithm - 2020 Executive Summary. Endocr Pract. 2020;26(10):1196-1224. doi:10.4158/CS-2020-0490
- Lloyd-Jones, D, Morris, P. et al. 2022 ACC Expert Consensus Decision Pathway on the Role of Nonstatin Therapies for LDL-Cholesterol Lowering in the Management of Atherosclerotic Cardiovascular Disease Risk: A Report of the American College of Cardiology Solution Set Oversight Committee. JACC. 2022 Oct, 80 (14) 1366-1418. <https://doi.org/10.1016/j.jacc.2022.07.006>
- D'Agostino RB Sr, Vasan RS, Pencina MJ, et al. General cardiovascular risk profile for use in primary care: the Framingham Heart Study. Circulation. 2008;117(6):743-753. doi:10.1161/CIRCULATIONAHA.107.699579
- Goff DC Jr, Lloyd-Jones DM, Bennett G, et al. 2013 ACC/AHA guideline on the assessment of cardiovascular risk: a report of the American College of Cardiology/American Heart Association Task Force on Practice Guidelines [published correction appears in Circulation. 2014 Jun 24;129(25 Suppl 2):S74-5]. Circulation. 2014;129(25 Suppl 2):S49-S73. doi:10.1161/01.cir.0000437741.48606.98
- Khan SS, Matsushita K, Sang Y, et al. Development and Validation of the American Heart Association's PREVENT Equations [published correction appears in Circulation. 2024 Mar 12;149(11):e956. doi: 10.1161/CIR.0000000000001230.]. Circulation. 2024;149(6):430-449. doi:10.1161/CIRCULATIONAHA.123.067626
- Devareddy A, Sarraju A, Rodriguez F. Health Disparities Across the Continuum of ASCVD Risk. Curr Cardiol Rep. 2022;24(9):1129-1137. doi:10.1007/s11886-022-01736-y
- Gordon M, Di Bartolo IM. Using Race with Caution in the ASCVD Calculator. Am Fam Physician. 2021;104(3):292-294.
- Perera K, Kam N, Ademi Z, Liew D, Zomer E. Bempedoic acid for high-risk patients with CVD as adjunct lipid-lowering therapy: A cost-effectiveness analysis. J Clin Lipidol. 2020;14(6):772-783. doi:10.1016/j.jacl.2020.08.013
- Nissen SE, Lincoff AM, Brennan D, et al. Bempedoic Acid and Cardiovascular Outcomes in Statin-Intolerant Patients. N Engl J Med. 2023;388(15):1353-1364. doi:10.1056/NEJMoa2215024
- Azari S, Rezapour A, Omidi N, et al. Cost-effectiveness analysis of PCSK9 inhibitors in cardiovascular diseases: a systematic review. Heart Fail Rev. 2020;25(6):1077-1088. doi:10.1007/s10741-019-09874-2
- Sabatine MS, Giugliano RP, Keech AC, et al. Evolocumab and Clinical Outcomes in Patients with Cardiovascular Disease. N Engl J Med. 2017;376(18):1713-1722. doi:10.1056/NEJMoa1615664
- Schwartz GG, Steg PG, Szarek M, et al. Alirocumab and Cardiovascular Outcomes after Acute Coronary Syndrome. N Engl J Med. 2018;379(22):2097-2107. doi:10.1056/NEJMoa1801174
- Ornish D, Scherwitz LW, Billings JH, et al. Intensive Lifestyle Changes for Reversal of Coronary Heart Disease. JAMA. 1998;280(23):2001-2007. doi:10.1001/jama.280.23.2001



# THANK YOU

Alexandria Taylor, PharmD, BCPS

[tayloram9@upmc.edu](mailto:tayloram9@upmc.edu)

# CORONARY ARTERY CALCIUM SCORING

<b>CACS</b>	<b>Recommendations</b>	<b>LDL-C Desired</b>
1-99 AU and < 75 <sup>th</sup> percentile for age/sex/race	Favor moderate-intensity statin therapy, especially in those ≥ 55 yr	30%-49% LDL-C reduction, consider high intensity if <30% reduction or LDL-C remains ≥ 100 mg/dL
>100 AU and > 75 <sup>th</sup> percentile for age/sex/race	Moderate to high intensity statin	LDL-C reduction, based on statin intensity
>300 AU and >75 <sup>th</sup> percentile for age/sex/race	High intensity statin	≥ 50% LDL-C reduction, consider ezetimibe if <50% LDL-C reduction or if LDL-C remains ≥ 70 mg/dL
>1000 AU	High intensity statin and possibly add on LDL-C lowering agent	≥ 50% LDL-C reduction, consider adding PCKS9i to statin +ezetimibe if <50% LDL-C reduction or if LDL-C remains ≥ 70 mg/dL

# MAYO CLINIC DECISION AID



Statin Choice  
Decision Aid

EN

FR

ES

中文

عربي

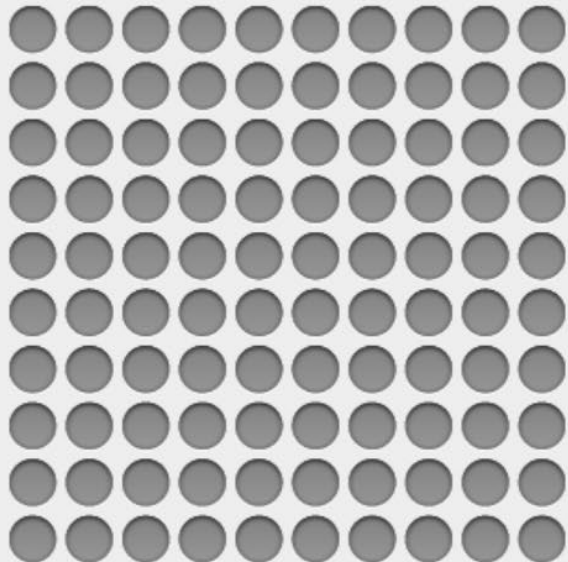

Welcome to the  
**Statin Choice**  
Decision Aid.

This tool will help you and your doctor discuss how you might want to reduce your risk for heart attacks.

[Let's get started](#)

**Caution:** This application is for use exclusively during the clinical encounter with your clinician

[Statin Choice Decision AID - Site](#)

# RISK ENHANCERS IN THE 2018 ACC/AHA BLOOD CHOLESTEROL GUIDELINES

- ABI <0.9
- CKD
- Early menopause (age <40 yr)
- Elevated ApoB  $\geq$  130 mg/dL
- Elevated hs-CRP  $\geq$  2 mg/L
- Elevated Lp(a)  $\geq$  125 nmol/L
- Elevated TG  $\geq$  175 mg/dL
- Family history of premature ASCVD ( male <55 yr, female <65 yr)
- High-risk ethnic groups (South Asian ancestry)
- Inflammatory diseases (RA, psoriasis, HIV)
- Metabolic syndrome
- Persistently elevated LDL-C concentrations  $\geq$  160 mg/dL
- Preeclampsia

# Benefits and Risks Associated With Statin Therapy for Primary Prevention in Old and Very Old Adults

## Real-World Evidence From a Target Trial Emulation Study

Wanchun Xu, MPhil; Amanda Lauren Lee, MS; Cindy Lo Kuen Lam, MD; Goodarz Danaei, ScD; and Eric Yuk Fai Wan, PhD

JAMA Internal Medicine | [Original Investigation](#) | LESS IS MORE

# Evaluation of Time to Benefit of Statins for the Primary Prevention of Cardiovascular Events in Adults Aged 50 to 75 Years

## A Meta-analysis

Lindsey C. Yourman, MD; Irena S. Cenzer, MA; W. John Boscardin, PhD; Brian T. Nguyen, BA; Alexander K. Smith, MD, MPH; Mara A. Schonberg, MD, MPH; Nancy L. Schoenborn, MD, MHS; Eric W. Widera, MD; Ariela Orkaby, MD, MPH; Annette Rodriguez, MA; Sei J. Lee, MD, MAS

In older adults without CVD, treating 100 (NNT) persons with statins for **2.5 years time-to-benefit** prevented 1 MACE



# A NONINFERIOR RCT COMPARED TREAT-TO-TARGET VS HIGH-INTENSITY STATINS

- Patients with coronary artery disease in South Korea (n=4400)
- Intervention group LDL target 50-70 mg/dL
- Comparison group received high intensity statin (rosuvastatin 20 mg or atorvastatin 40mg)
- Primary end point was a 3-year composite of death, myocardial infarction, stroke, or coronary revascularization
  - 8.1% in treat to target
  - 8.7% in high intensity statin (mean LDL was 68.4 mg/dL)
- Noninferior treat-to-target vs high-intensity statins

Observational Study

> CMAJ. 2020 Apr 27;192(17):E442-E449. doi: 10.1503/cmaj.190848.

## Calibration and discrimination of the Framingham Risk Score and the Pooled Cohort Equations

Dennis T Ko <sup>1</sup>, Atul Sivaswamy <sup>2</sup>, Maneesh Sud <sup>2</sup>, Gynter Kotrri <sup>2</sup>, Paymon Azizi <sup>2</sup>, Maria Koh <sup>2</sup>, Peter C Austin <sup>2</sup>, Douglas S Lee <sup>2</sup>, Idan Roifman <sup>2</sup>, George Thanassoulis <sup>2</sup>, Karen Tu <sup>2</sup>, Jacob A Udell <sup>2</sup>, Harindra C Wijeyesundera <sup>2</sup>, Todd J Anderson <sup>2</sup>

Affiliations + expand

PMID: 32392491 PMCID: [PMC7207198](#) DOI: [10.1503/cmaj.190848](#)

The predicted event rate of 5.78% by the Framingham Risk Score and 3.51% by the Pooled Cohort Equations at 5 years **overestimated** observed **event rates by 101% and 115%**, respectively

# STATINS

## Low Intensity

LDL lowering <30%  
Simvastatin 10 mg  
Pravastatin 10&20 mg  
Lovastatin 20 mg  
Fluvastatin 20-40 mg

## Moderate Intensity

LDL lowering 30-49%  
Atorvastatin 10&20 mg  
Rosuvastatin 5&10 mg  
Simvastatin 20&40 mg  
Pravastatin 40&80 mg  
Lovastatin 40&80 mg  
Fluvastatin XL 80 mg  
Pitavastatin 1-4 mg

## High Intensity

LDL lowering 30-49%  
Atorvastatin 40&80 mg  
Rosuvastatin 20&40 mg

\*Simvastatin, Fluvastatin must be taken at bedtime

\*\*Lovastatin must be taken with evening meal

# Getting Back to Our “Why”: Reclaiming the Joy in Medicine

Caitlin Matthis, DO, FAAFP  
UPMC Washington Family Medicine Residency  
March 7, 2025

slido

Please download and install the Slido app on all computers you use



# Who do we have here today?

① Start presenting to display the poll results on this slide.

**slido**

Please download and install the Slido app on all computers you use



**What is your happiness score?**

① Start presenting to display the poll results on this slide.

# Why I Am Here Today: My Burnout Story



# Where is your wellness currently?

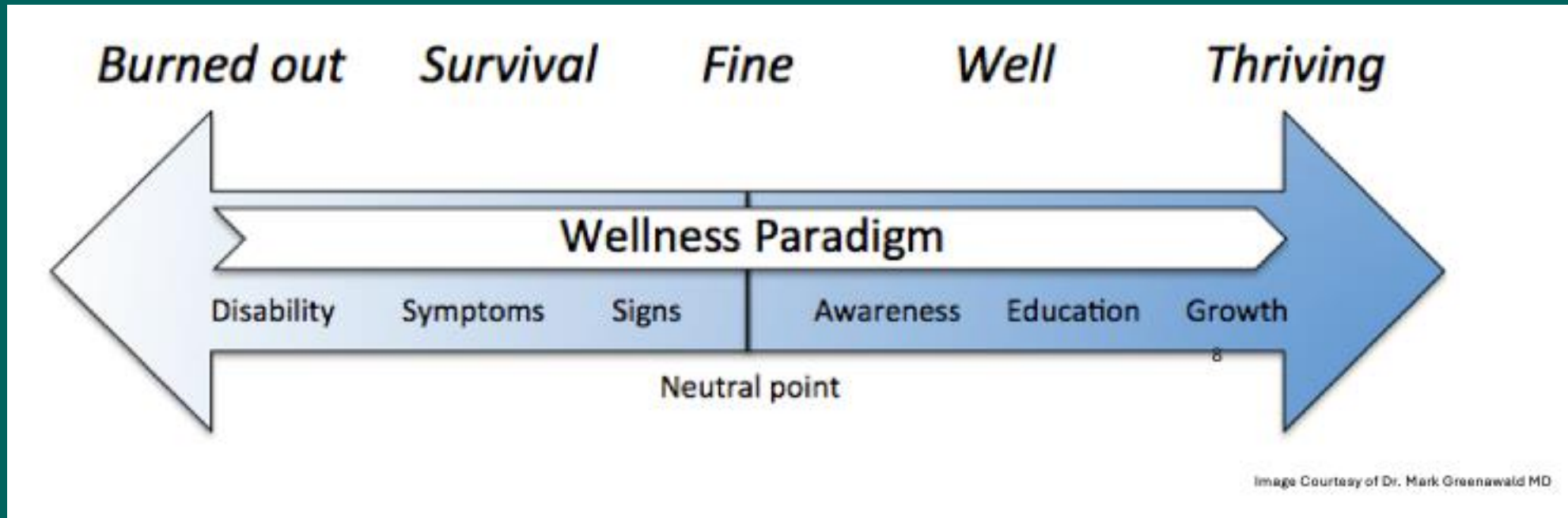



**slido**

Please download and install the Slido app on all computers you use



# Where is your wellness currently?

① Start presenting to display the poll results on this slide.

# Objectives



Describe the current landscape of family medicine.



Understand our “why” for choosing family medicine—including through the framework of our core values.



Learn the power of gratitude practices on our overall happiness.

# Objectives



Describe the current landscape of family medicine.

# Landscape of Medicine



---

**AAFP CME**

## Why Are We Here

*The Burnout Impact on Physician Well-being*

Margot Savoy, MD, MPH, FAAFP  
May 6, 2024 | Scottsdale, AZ  
2024 Physician Health & Well-being Conference

AAFP CME

# Struggle of Family Medicine

- There are less of us around
- We are seeing a lot of complex patients
- We are doing a lot of paperwork
- This is burning us out

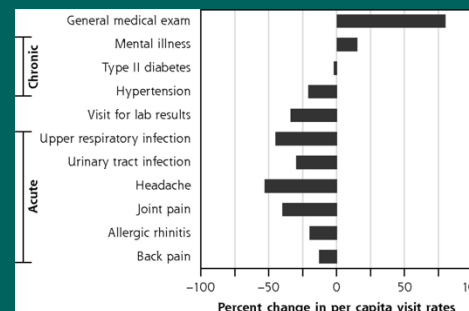
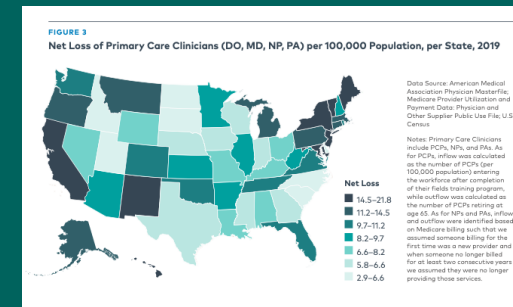
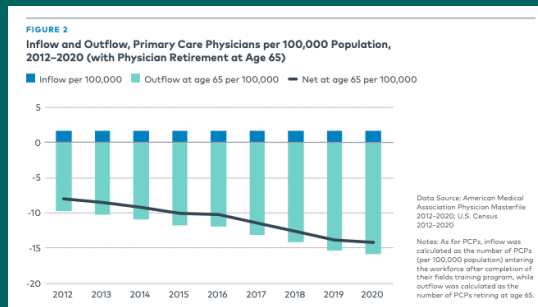

	2008 <sup>a</sup>	2015 <sup>a</sup>	Percent Change <sup>b</sup>	8-Year Trend <sup>c</sup> (95% CI)
Mean visit duration, min <sup>d</sup>	19.3	21.6	12	2.4 (1.1-3.8)
Mean diagnoses, No. <sup>e</sup>	2.0	2.3	15	0.30 (0.16-0.43)
Mean medications, No. <sup>f</sup>	3.1	3.9	26	0.82 (0.59-1.1)
Mean preventive services, No. <sup>g</sup>	0.34	0.59	76	0.24 (0.12-0.36)
Mean procedures, No. <sup>h</sup>	0.06	0.08	33	0.02 (0.01-0.03)

NACMS = National Ambulatory Medical Care Survey.

**Table 3. Average Time Spent Per Day by EHR Task Category, Comparing Work Hours and After Hours**

EHR Task Category	Time Spent per Day, min			Total Time Spent per Day, min (% of Daily Total)
	Work Hours	After Hours	Ratio	
<b>Clinical</b>				
Documentation	64	20	3.2	84 (23.7)
Order Entry	35	8	4.4	43 (12.1)
Billing and Coding	10	4	2.5	14 (3.9)
System Security	8	2	4.0	10 (2.8)
Administrative	4	2	2.0	6 (1.7)
Subtotal	121	36	3.4	157 (44.2)
<b>Medical care</b>				
Chart Review - Notes	47	13	3.6	60 (16.9)
Chart Review - Medications	21	5	4.2	26 (7.3)
Problem List	8	4	2.0	12 (3.4)
Chart Review - Laboratories	6	3	2.0	9 (2.5)
EBM, Point of Care	2	2	1.0	4 (1.1)
Chart Review - Imaging	2	1	2.0	3 (0.8)
Subtotal	86	28	3.1	114 (32.1)
<b>Inbox</b>				
Results and Results Management	41	14	2.9	55 (15.5)
MyChart Portal	15	5	3.0	20 (5.6)
Telephone Call	5	2	2.5	7 (2.0)
Letter Generation	1	1	1.0	2 (0.6)
Subtotal	62	22	2.8	84 (23.7)
<b>Total</b>	269	86	3.1	355 (100.0)

EBM = evidence-based medicine; EHR = electronic health record.

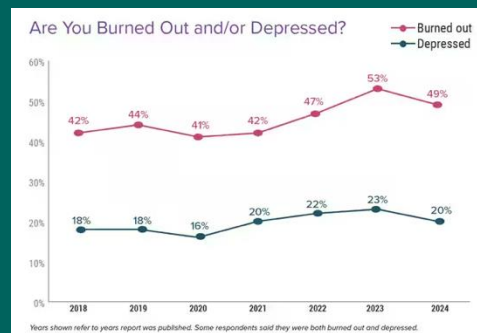



# Struggle of Family Medicine

- There are less of us around
- We are seeing a lot of complex patients
- We are doing a lot of paperwork
- This is burning us out

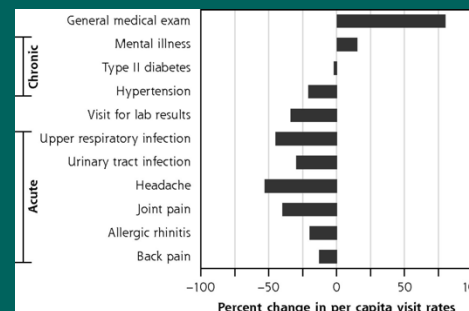
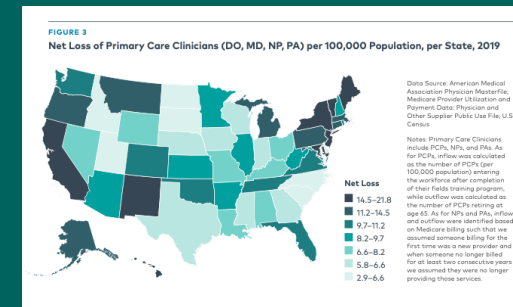
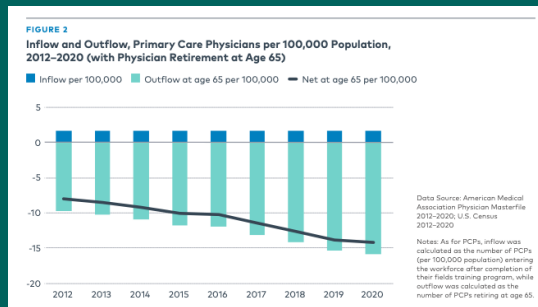

	2008 <sup>a</sup>	2015 <sup>a</sup>	Percent Change <sup>b</sup>	8-Year Trend <sup>d</sup> (95% CI)
Mean visit duration, min <sup>d</sup>	19.3	21.6	12	2.4 (1.1-3.8)
Mean diagnoses, No. <sup>e</sup>	2.0	2.3	15	0.30 (0.16-0.43)
Mean medications, No. <sup>f</sup>	3.1	3.9	26	0.82 (0.59-1.1)
Mean preventive services, No. <sup>g</sup>	0.34	0.59	76	0.24 (0.12-0.36)
Mean procedures, No. <sup>h</sup>	0.06	0.08	33	0.02 (0.01-0.03)

NACMS = National Ambulatory Medical Care Survey.

**Table 3. Average Time Spent Per Day by EHR Task Category, Comparing Work Hours and After Hours**

EHR Task Category	Time Spent per Day, min			Total Time Spent per Day, min (% of Daily Total)
	Work Hours	After Hours	Ratio	
<b>Clinical</b>				
Documentation	64	20	3.2	84 (23.7)
Order Entry	35	8	4.4	43 (12.1)
Billing and Coding	10	4	2.5	14 (3.9)
System Security	8	2	4.0	10 (2.8)
Administrative	4	2	2.0	6 (1.7)
Subtotal	121	36	3.4	157 (44.2)
<b>Medical care</b>				
Chart Review - Notes	47	13	3.6	60 (16.9)
Chart Review - Medications	21	5	4.2	26 (7.3)
Problem List	8	4	2.0	12 (3.4)
Chart Review - Laboratories	6	3	2.0	9 (2.5)
EBM, Point of Care	2	2	1.0	4 (1.1)
Chart Review - Imaging	2	1	2.0	3 (0.8)
Subtotal	86	28	3.1	114 (32.1)
<b>Inbox</b>				
Results and Results Management	41	14	2.9	55 (15.5)
MyChart Portal	15	5	3.0	20 (5.6)
Telephone Call	5	2	2.5	7 (2.0)
Letter Generation	1	1	1.0	2 (0.6)
Subtotal	62	22	2.8	84 (23.7)
<b>Total</b>	269	86	3.1	355 (100.0)

EBM = evidence-based medicine; EHR = electronic health record.

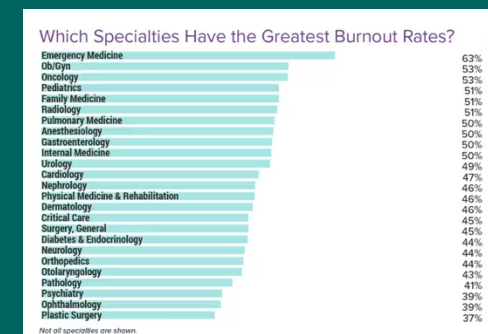
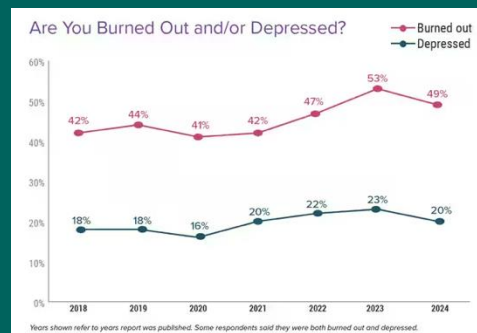

# Struggle of Family Medicine

- There are less of us around
- We are seeing a lot of complex patients

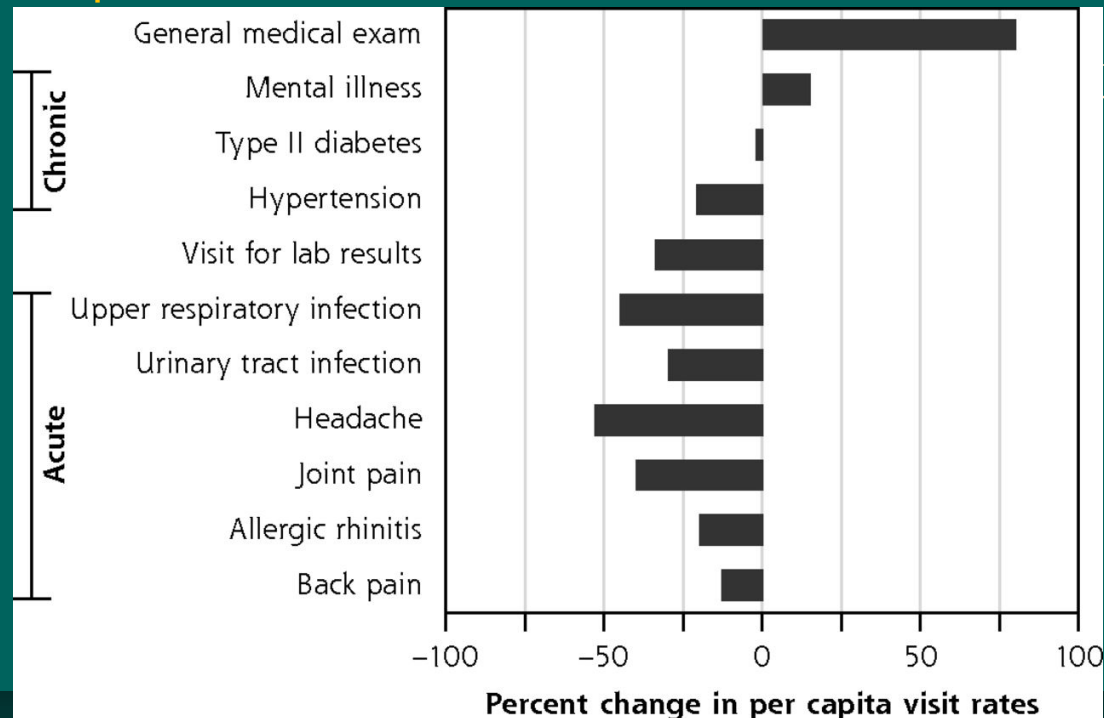

	2008 <sup>a</sup>	2015 <sup>a</sup>	Percent Change <sup>b</sup>	8-Year Trend <sup>c</sup> (95% CI)
Mean visit duration, min <sup>d</sup>	19.3	21.6	12	2.4 (1.1-3.8)
Mean diagnoses, No. <sup>e</sup>	2.0	2.3	15	0.30 (0.16-0.43)
Mean medications, No. <sup>f</sup>	3.1	3.9	26	0.82 (0.59-1.1)
Mean preventive services, No. <sup>g</sup>	0.34	0.59	76	0.24 (0.12-0.36)
Mean procedures, No. <sup>h</sup>	0.06	0.08	33	0.02 (0.01-0.03)

NACMS = National Ambulatory Medical Care Survey.

Rao A, Shi Z, Ray KN, Mehrotra A, Ganguli I. National Trends in Primary Care Visit Use and Practice Capabilities, 2008-2015. *Ann Fam Med*. 2019 Nov;17(6):538-544. doi: 10.1370/afm.2474. PMID: 31712292; PMCID: PMC6846275.



# Struggle of Family Medicine

- There are less of us around
- We are seeing a lot of complex patients
- We are doing a lot of paperwork
- This is burning us out

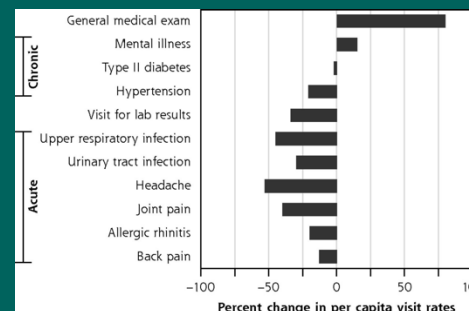
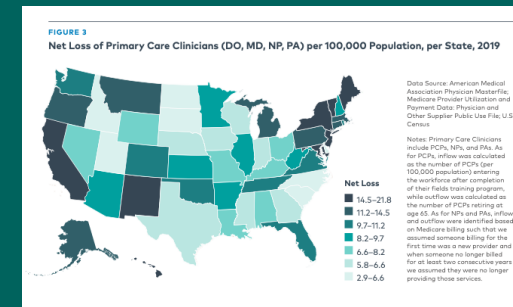
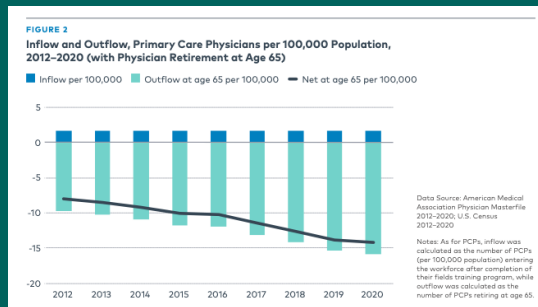

	2008 <sup>a</sup>	2015 <sup>a</sup>	Percent Change <sup>b</sup>	8-Year Trend <sup>d</sup> (95% CI)
Mean visit duration, min <sup>d</sup>	19.3	21.6	12	2.4 (1.1-3.8)
Mean diagnoses, No. <sup>e</sup>	2.0	2.3	15	0.30 (0.16-0.43)
Mean medications, No. <sup>f</sup>	3.1	3.9	26	0.82 (0.59-1.1)
Mean preventive services, No. <sup>g</sup>	0.34	0.59	76	0.24 (0.12-0.36)
Mean procedures, No. <sup>h</sup>	0.06	0.08	33	0.02 (0.01-0.03)

NACMS = National Ambulatory Medical Care Survey.

**Table 3. Average Time Spent Per Day by EHR Task Category, Comparing Work Hours and After Hours**

EHR Task Category	Time Spent per Day, min			Total Time Spent per Day, min (% of Daily Total)
	Work Hours	After Hours	Ratio	
<b>Clinical</b>				
Documentation	64	20	3.2	84 (23.7)
Order Entry	35	8	4.4	43 (12.1)
Billing and Coding	10	4	2.5	14 (3.9)
System Security	8	2	4.0	10 (2.8)
Administrative	4	2	2.0	6 (1.7)
Subtotal	121	36	3.4	157 (44.2)
<b>Medical care</b>				
Chart Review - Notes	47	13	3.6	60 (16.9)
Chart Review - Medications	21	5	4.2	26 (7.3)
Problem List	8	4	2.0	12 (3.4)
Chart Review - Laboratories	6	3	2.0	9 (2.5)
EBM, Point of Care	2	2	1.0	4 (1.1)
Chart Review - Imaging	2	1	2.0	3 (0.8)
Subtotal	86	28	3.1	114 (32.1)
<b>Inbox</b>				
Results and Results Management	41	14	2.9	55 (15.5)
MyChart Portal	15	5	3.0	20 (5.6)
Telephone Call	5	2	2.5	7 (2.0)
Letter Generation	1	1	1.0	2 (0.6)
Subtotal	62	22	2.8	84 (23.7)
<b>Total</b>	269	86	3.1	355 (100.0)

EBM = evidence-based medicine; EHR = electronic health record.

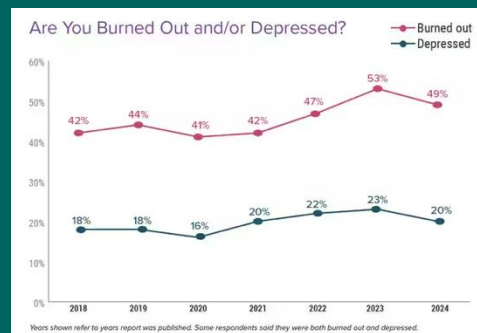

# Struggle of Family Medicine

- There are less of us around
- We are seeing a lot of complex patients
- We are doing a lot of paperwork
- This is burning us out

-average 11.4-hour workday  
 -1/2 of this is spent in the EHR  
 -average of almost 1 1/2 after hours EMR use

**Table 3. Average Time Spent Per Day by EHR Task Category, Comparing Work Hours and After Hours**

EHR Task Category	Time Spent per Day, min			Total Time Spent per Day, min (% of Daily Total)
	Work Hours	After Hours	Ratio	
<b>Clerical</b>				
Documentation	64	20	3.2	84 (23.7)
Order Entry	35	8	4.4	43 (12.1)
Billing and Coding	10	4	2.5	14 (3.9)
System Security	8	2	4.0	10 (2.8)
Administrative	4	2	2.0	6 (1.7)
Subtotal	121	36	3.4	157 (44.2)
<b>Medical care</b>				
Chart Review – Notes	47	13	3.6	60 (16.9)
Chart Review – Medications	21	5	4.2	26 (7.3)
Problem List	8	4	2.0	12 (3.4)
Chart Review – Laboratories	6	3	2.0	9 (2.5)
EBM, Point of Care	2	2	10	4 (1.1)
Chart Review – Imaging	2	1	2.0	3 (0.8)
Subtotal	86	28	3.1	114 (32.1)
<b>Inbox</b>				
Refills and Results Management	41	14	2.9	55 (15.5)
MyChart Portal	15	5	3.0	20 (5.6)
Telephone Call	5	2	2.5	7 (2.0)
Letter Generation	1	1	1.0	2 (0.6)
Subtotal	62	22	2.8	84 (23.7)
<b>Total</b>	<b>269</b>	<b>86</b>	<b>3.1</b>	<b>355 (100.0)</b>

EBM = evidence-based medicine; EHR = electronic health record.

# Struggle of Family Medicine

- There are less of us around
- We are seeing a lot of complex patients
- We are doing a lot of paperwork
- This is burning us out

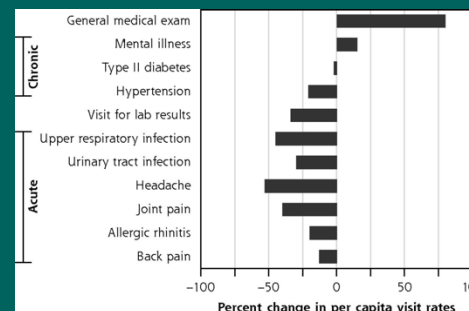
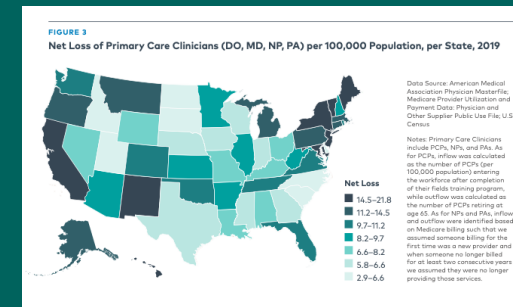
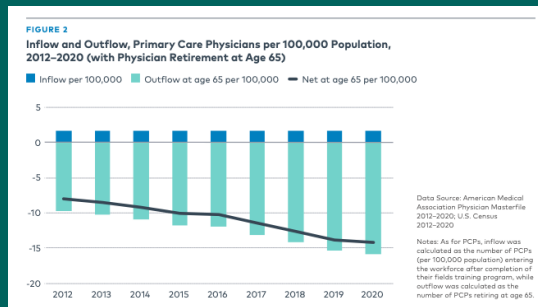

	2008 <sup>a</sup>	2015 <sup>a</sup>	Percent Change <sup>b</sup>	8-Year Trend <sup>c</sup> (95% CI)
Mean visit duration, min <sup>d</sup>	19.3	21.6	12	2.4 (1.1-3.8)
Mean diagnoses, No. <sup>e</sup>	2.0	2.3	15	0.30 (0.16-0.43)
Mean medications, No. <sup>f</sup>	3.1	3.9	26	0.82 (0.59-1.1)
Mean preventive services, No. <sup>g</sup>	0.34	0.59	76	0.24 (0.12-0.36)
Mean procedures, No. <sup>h</sup>	0.06	0.08	33	0.02 (0.01-0.03)

NACMS = National Ambulatory Medical Care Survey.

**Table 3. Average Time Spent Per Day by EHR Task Category, Comparing Work Hours and After Hours**

EHR Task Category	Time Spent per Day, min			Total Time Spent per Day, min (% of Daily Total)
	Work Hours	After Hours	Ratio	
<b>Clinical</b>				
Documentation	64	20	3.2	84 (23.7)
Order Entry	35	8	4.4	43 (12.1)
Billing and Coding	10	4	2.5	14 (3.9)
System Security	8	2	4.0	10 (2.8)
Administrative	4	2	2.0	6 (1.7)
Subtotal	121	36	3.4	157 (44.2)
<b>Medical care</b>				
Chart Review - Notes	47	13	3.6	60 (16.9)
Chart Review - Medications	21	5	4.2	26 (7.3)
Problem List	8	4	2.0	12 (3.4)
Chart Review - Laboratories	6	3	2.0	9 (2.5)
EBM, Point of Care	2	2	1.0	4 (1.1)
Chart Review - Imaging	2	1	2.0	3 (0.8)
Subtotal	86	28	3.1	114 (32.1)
<b>Inbox</b>				
Results and Results Management	41	14	2.9	55 (15.5)
MyChart Portal	15	5	3.0	20 (5.6)
Telephone Call	5	2	2.5	7 (2.0)
Letter Generation	1	1	1.0	2 (0.6)
Subtotal	62	22	2.8	84 (23.7)
<b>Total</b>	269	86	3.1	355 (100.0)

EBM = evidence-based medicine; EHR = electronic health record.

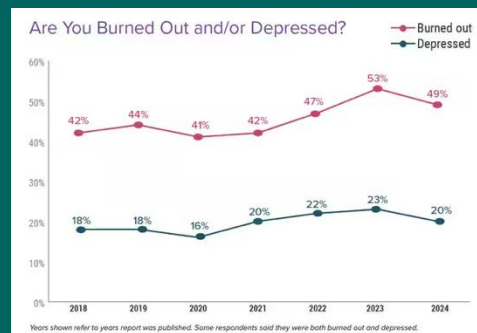

# Struggle of Family Medicine

- There are less of us around
- We are seeing a lot of complex patients
- We are doing a lot of paperwork
- This is burning us out

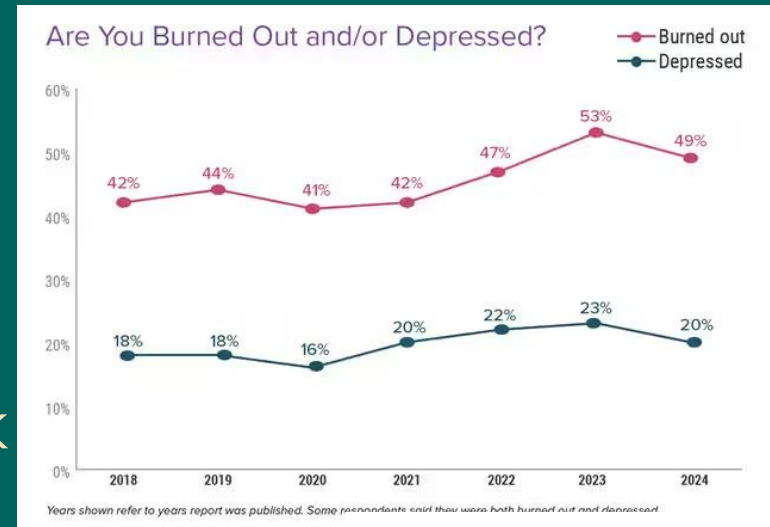

## Which Specialties Have the Greatest Burnout Rates?

Emergency Medicine	63%
Ob/Gyn	53%
Oncology	53%
Pediatrics	51%
Family Medicine	51%
Radiology	51%
Pulmonary Medicine	50%
Anesthesiology	50%
Gastroenterology	50%
Internal Medicine	50%
Urology	49%
Cardiology	47%
Nephrology	46%
Physical Medicine & Rehabilitation	46%
Dermatology	46%
Critical Care	45%
Surgery, General	45%
Diabetes & Endocrinology	44%
Neurology	44%
Orthopedics	44%
Otolaryngology	43%
Pathology	41%
Psychiatry	39%
Ophthalmology	39%
Plastic Surgery	37%

McKenna, Jon. Medscape Physician Burnout and Depression Report 2024: 'We Have Much Work to Do'. 26 Jan 2024.

Not all specialties are shown.

**WHAT WE DO MATTERS**



*"My doctor is real easy to talk to. She listens to my questions and seems to really care."*



*“Because he is extremely knowledgeable and is responsible for my being alive today.”*

A photograph of a male doctor in a white lab coat examining a female patient with curly hair in a clinic. The doctor is on the left, looking at the patient on the right. He is gently touching her face. The background shows a window with blinds, a clock on the wall, and a poster of human anatomy.

*“(The) doctor takes the time to converse and examine, striving to help me be healthier.”*



*"She is very pleasant and friendly. She always prescribes the right medicine the first time around."*





*"Because he is an excellent doctor. He knows me and understands my medical needs."*



The Physician's Foundation (19 January 2022) *Consumer attitudes toward family / primary care physicians ...* Available at: [https://physiciansfoundation.org/wp-content/uploads/2018/01/Physicians\\_Foundation\\_Consumer\\_Omnibus\\_Survey.pdf](https://physiciansfoundation.org/wp-content/uploads/2018/01/Physicians_Foundation_Consumer_Omnibus_Survey.pdf) (Accessed: 28 February 2025).  
Savoy, M., MD, MPH, FFAFP (2024, May 6). *Why Are We Here: The Burnout Impact on Physician Well-Being* [2024 Physician Health and Well-Being Conference Presentation].

**YOU  
LITERALLY  
GIVE US  
LIFE**



Basu S, Berkowitz SA, Phillips RL, Bitton A, Landon BE, Phillips RS. Association of Primary Care Physician Supply With Population Mortality in the United States, 2005-2015. *JAMA Intern Med.* 2019;179(4):506-514. doi:10.1001/jamainternmed.2018.7624

Savoy, M., MD, MPH, FAAFP (2024, May 6). *Why Are We Here: The Burnout Impact on Physician Well-Being* [2024 Physician Health and Well-Being Conference Presentation].

# Objectives



Describe the current landscape of family medicine.



Understand our “why” for choosing family medicine—including through the framework of our core values.



Learn the power of gratitude practices on our overall happiness.

# Objectives



Understand our “why” for choosing family medicine- including through the framework of our core values.

# YOUR WHY

Promise me you will not spend so much time treading water and trying to keep your head above the waves that you forget, truly forget, how much you have always loved to swim.

Tyler Knott Gregson

“ quotez fancy

**slido**

Please download and install the Slido app on all computers you use



# Why did you choose medicine?

① Start presenting to display the poll results on this slide.



# Core Values Exercise

- Circle the 10-15 that first come to mind
- Slowly narrow down to:

2



## List of VALUES

- |                |                     |                      |                        |
|----------------|---------------------|----------------------|------------------------|
| Accountability | Ethics              | Kindness             | Self-respect           |
| Achievement    | Excellence          | Knowledge            | Serenity               |
| Adaptability   | Fairness            | Leadership           | Service                |
| Adventure      | Faith               | Learning             | Simplicity             |
| Altruism       | Family              | Legacy               | Spirituality           |
| Ambition       | Financial stability | Leisure              | Sportsmanship          |
| Authenticity   | Forgiveness         | Love                 | Stewardship            |
| Balance        | Freedom             | Loyalty              | Success                |
| Beauty         | Friendship          | Making a difference  | Teamwork               |
| Being the best | Fun                 | Nature               | Thrift                 |
| Belonging      | Future generations  | Openness             | Time                   |
| Career         | Generosity          | Optimism             | Tradition              |
| Caring         | Giving back         | Order                | Travel                 |
| Collaboration  | Grace               | Parenting            | Trust                  |
| Commitment     | Gratitude           | Patience             | Truth                  |
| Community      | Growth              | Patriotism           | Understanding          |
| Compassion     | Harmony             | Peace                | Uniqueness             |
| Competence     | Health              | Perseverance         | Usefulness             |
| Confidence     | Home                | Personal fulfillment | Vision                 |
| Connection     | Honesty             | Power                | Vulnerability          |
| Contentment    | Hope                | Pride                | Wealth                 |
| Contribution   | Humility            | Recognition          | Well-being             |
| Cooperation    | Humor               | Reliability          | Wholeheartedness       |
| Courage        | Inclusion           | Resourcefulness      | Wisdom                 |
| Creativity     | Independence        | Respect              |                        |
| Curiosity      | Initiative          | Responsibility       | <i>Write your own:</i> |
| Dignity        | Integrity           | Risk-taking          | _____                  |
| Diversity      | Intuition           | Safety               | _____                  |
| Environment    | Job security        | Security             | _____                  |
| Efficiency     | Joy                 | Self-discipline      | _____                  |
| Equality       | Justice             | Self-expression      | _____                  |

# PAIR AND SHARE



**slido**

Please download and install the Slido app on all computers you use



## Using your core values: Why did you choose medicine?

① Start presenting to display the poll results on this slide.

# Objectives



Describe the current landscape of family medicine.



Understand our “why” for choosing family medicine—including through the framework of our core values.



Learn the power of gratitude practices on our overall happiness.

# Objectives



Learn the power of gratitude practices on our overall happiness.

# THE POWER (AND SCIENCE) OF GRATITUDE

Gratitude makes the hard stuff  
bearable and the good stuff  
even sweeter.

COURTNEY CARVER

# Gratitude: Writing Activity

- Think of someone from your journey through medicine that you are grateful for
- Write a paragraph explaining why you are grateful for them.



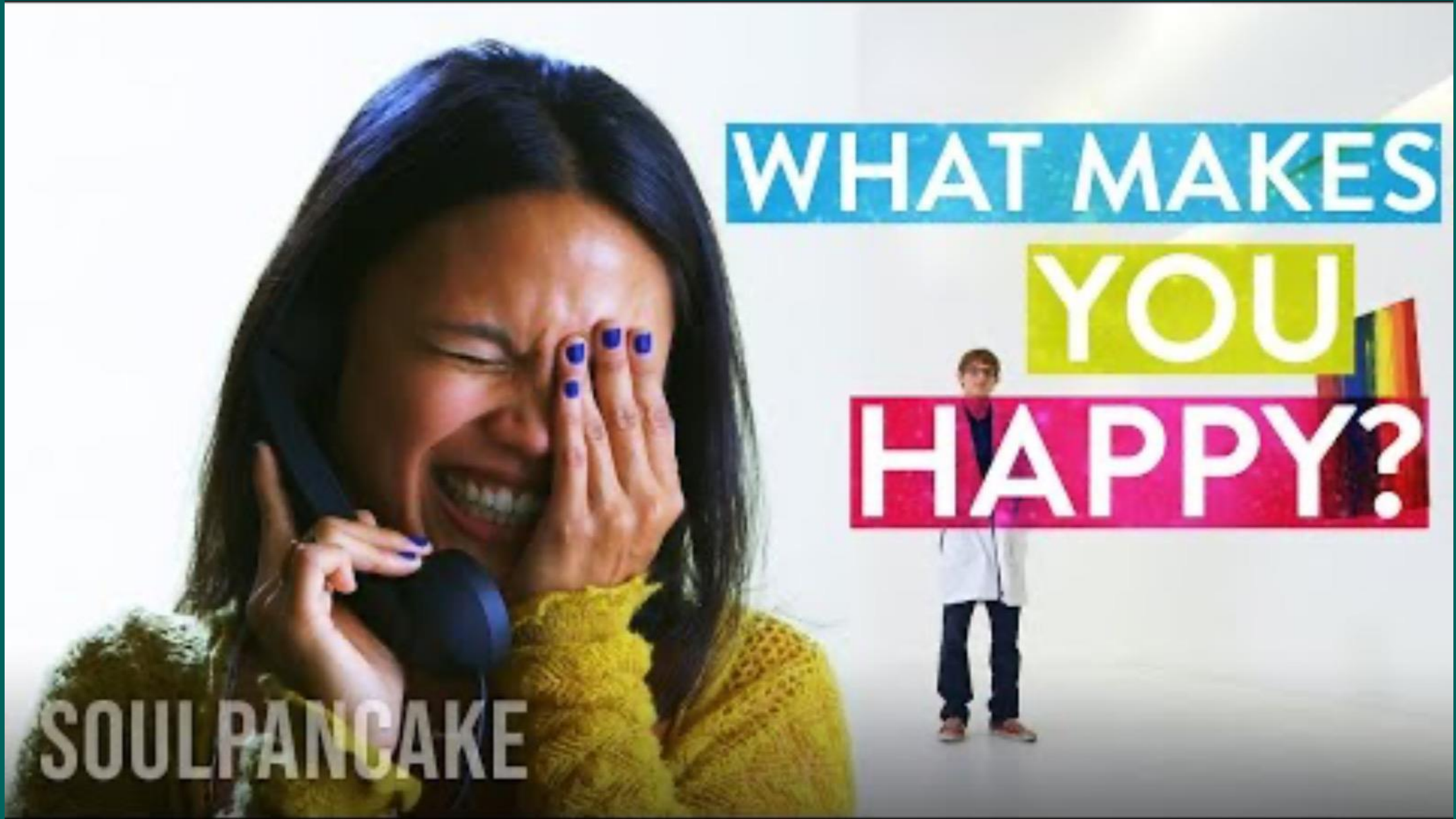

**SOULPANCAKE**

**WHAT MAKES  
YOU  
HAPPY?**



## Steen Happiness Index Scores

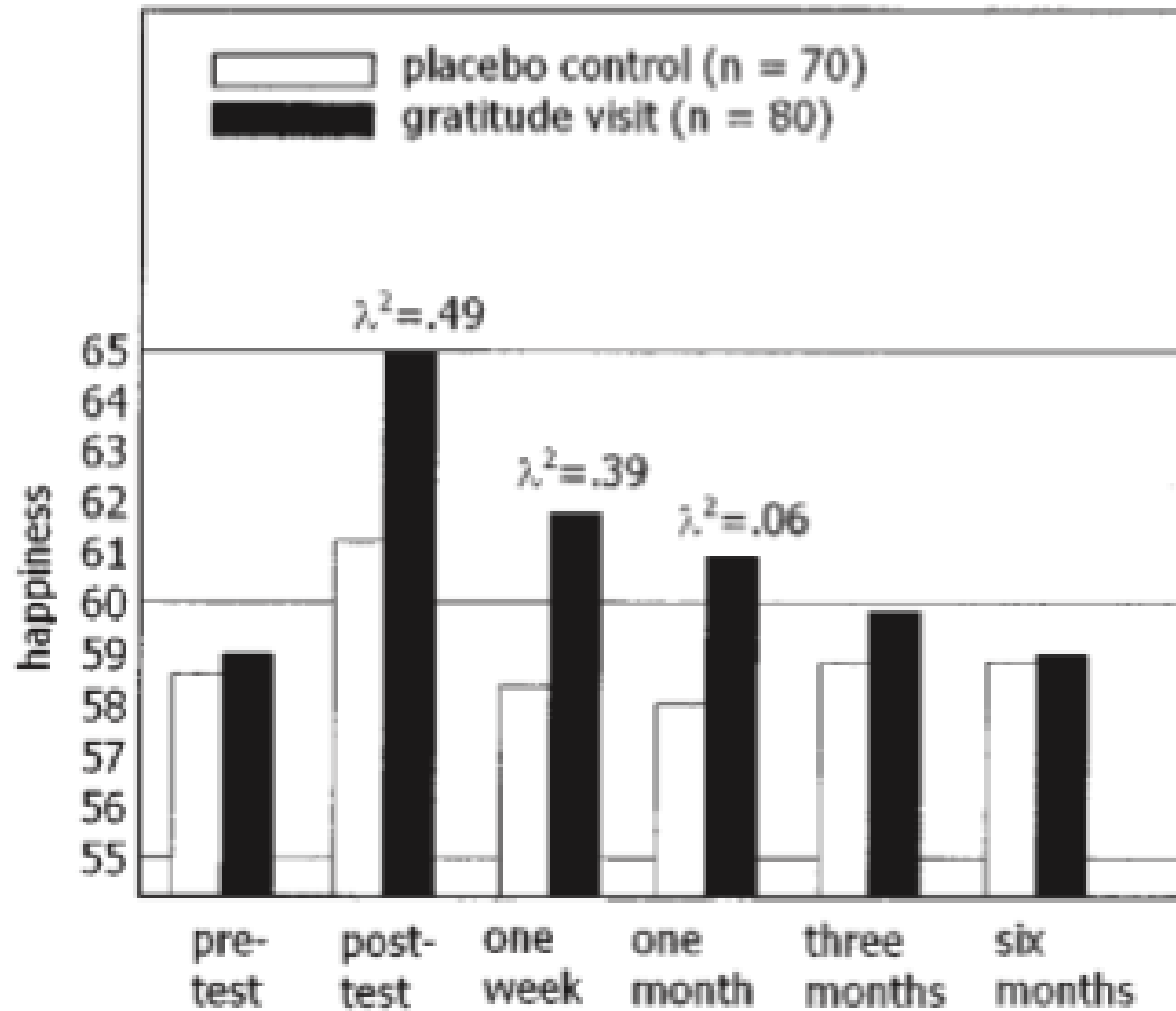

# 3 Good Things

- Reflect and write down 3 good things that happened yesterday.
- Write 1-2 sentences explaining why they were good.



# 3 Good Things

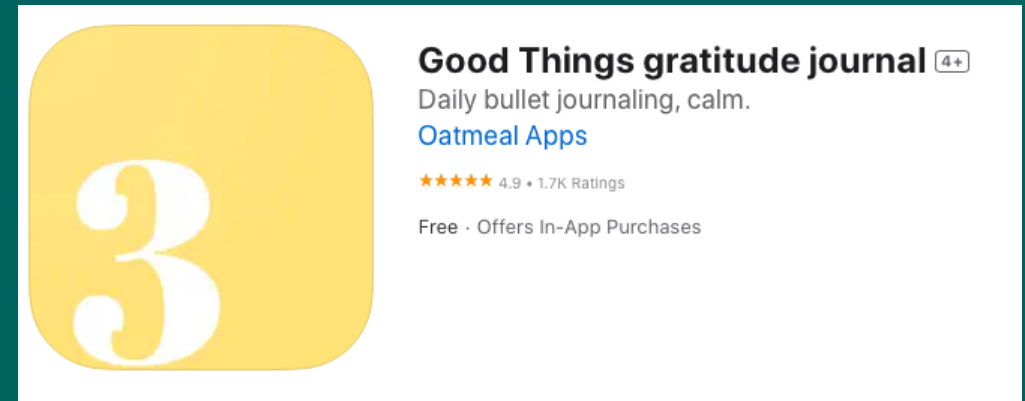
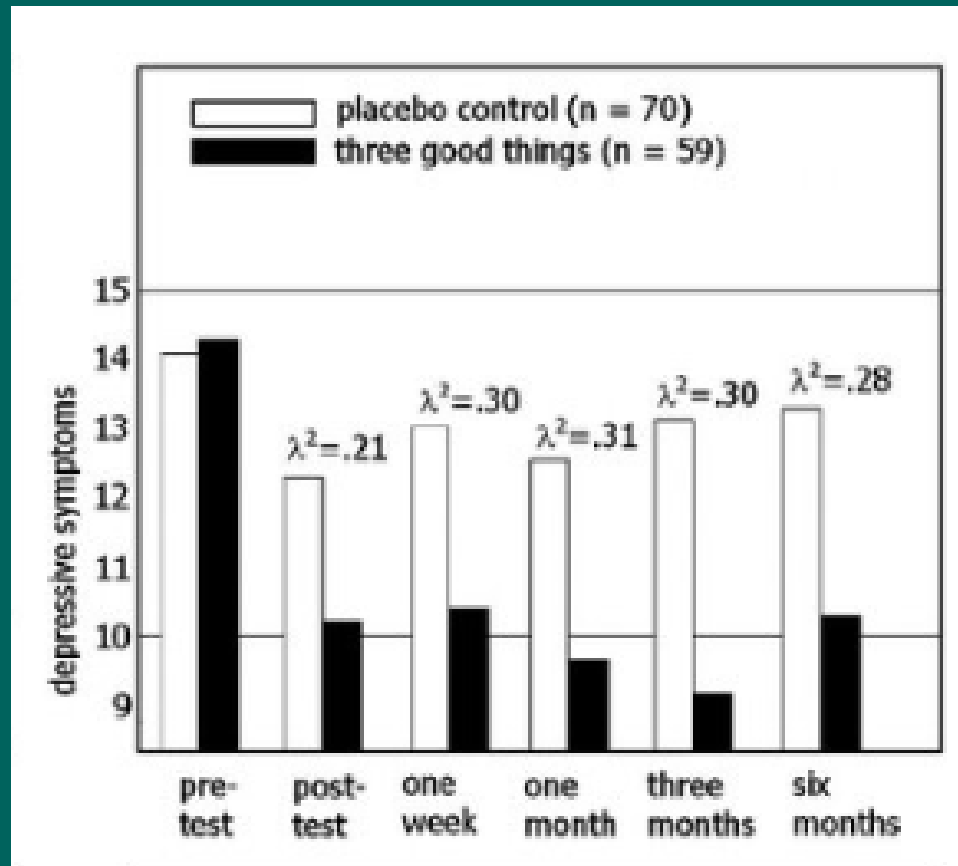

**slido**

Please download and install the Slido app on all computers you use



# What are your 3 Good Things?

① Start presenting to display the poll results on this slide.

**slido**

Please download and install the Slido app on all computers you use



**What is your happiness score?**

① Start presenting to display the poll results on this slide.

**slido**

Please download and install the Slido app on all computers you use



## Audience Q&A

① Start presenting to display the audience questions on this slide.

# Resources

1. *An Experiment in Gratitude | The Science of Happiness (2013) YouTube*. Available at: <https://www.youtube.com/watch?start=17&feature=oembed&v=oHv6vTKD6lg> (Accessed: 27 February 2025).
2. Arndt, Brian G., et al. "Tethered to the EHR: primary care physician workload assessment using EHR event log data and time-motion observations." *The Annals of Family Medicine* 15.5 (2017): 419-426.
3. Basu S, Berkowitz SA, Phillips RL, Bitton A, Landon BE, Phillips RS. Association of Primary Care Physician Supply With Population Mortality in the United States, 2005-2015. *JAMA Intern Med*. 2019;179(4):506-514. doi:10.1001/jamainternmed.2018.7624
4. Brown, Brené. *Dare to lead list of values (2023) Brené Brown*. Available at: <https://brenebrown.com/resources/dare-to-lead-list-of-values/> (Accessed: 27 February 2025).
5. Huffstetler, A., A. Greiner, and A. Siddiqi. "Health is primary: charting a path to equity and sustainability." *Primary Care Collaborative and the Robert Graham Center*. <https://www.graham-center.org/content/dam/rgc/documents/publications-reports/reports/pcc-evidence-report-2023.pdf>. Published (2023).
6. McKenna, Jon. Medscape Physician Burnout and Depression Report 2024: 'We Have Much Work to Do'. 26 Jan 2024.
7. Rao A, Shi Z, Ray KN, Mehrotra A, Ganguli I. National Trends in Primary Care Visit Use and Practice Capabilities, 2008-2015. *Ann Fam Med*. 2019 Nov;17(6):538-544. doi: 10.1370/afm.2474. PMID: 31712292; PMCID: PMC6846275.
8. Savoy, M., MD, MPH, FAAFP (2024, May 6). *Why Are We Here: The Burnout Impact on Physician Well-Being* [2024 Physician Health and Well-Being Conference Presentation].
9. Seligman ME, Steen TA, Park N, Peterson C. Positive psychology progress: empirical validation of interventions. *Am Psychol*. 2005;60(5):410-421

## Images:

1. Gratitude Image: <https://bemorewithless.com/grace-gratitude/>
2. Swim Image: Images from Quotefancy.com
3. Wellness Continuum: Dr. Mark Greenawald

# Thank You

Caitlin Matthis, DO, FAAFP  
[matthiscc@upmc.edu](mailto:matthiscc@upmc.edu)



# PEP and PrEP

St Margaret Family Medicine Refresher Course

Jesse Gordon D.O.

March 7 2025

# Outline

HIV statistics

PEP Criteria, Meds, Barriers

PrEP Criteria, Meds, Monitoring, Barriers

Doxy PEP

Contact info

# HIV statistics

**World** 40 million people living with HIV

**US** 1.2 million people living with HIV

**Pennsylvania** 36,000 people living with HIV

**Allegheny County** 4000 people living with HIV.

66 new cases in 2023. In 2015 139 new cases.



# Who is at risk?

- Gay, bisexual, and other men who have sex with men, in particular Black, Latino, and American Indian/Alaska Native men
- Transgender women
- People who inject drugs
- Black women
- Youth aged 13–24 years
- People with STI in past year
- People with an HIV+ partner
- Anyone who requests PrEP



## nPEP Criteria

Rapid HIV testing

Pregnancy testing for people with uterus

Determining need for empiric treatment for other STIs

Initiation within 72 hours of exposure

OK for exposure to HIV+ partners or partners of unknown HIV status



# PEP meds

CDC recommends

Tenofovir disoproxil fumarate-emtricitabine (TDF-FTC) or TAF-FTC

Plus

Dolutegravir

But many clinicians use other one tablet 3 drug regimens like Biktarvy

- Bictegravir (an integrase inhibitor)
- Emtricitabine (a nucleoside reverse transcriptase inhibitor)
- Tenofovir alafenamide (a nucleoside reverse transcriptase inhibitor)

Continue for 28 days



# Barriers to PEP use

Patient awareness

Access within 72 hours

Clinician knowledge and experience



# PrEP Criteria

Rapid HIV testing (resulted before starting)

HBV surface antigen, surface antibody, and core antibody.

Full STI –include throat and rectal swab if using those parts  
for sex

Serum Creatinine

Pregnancy testing

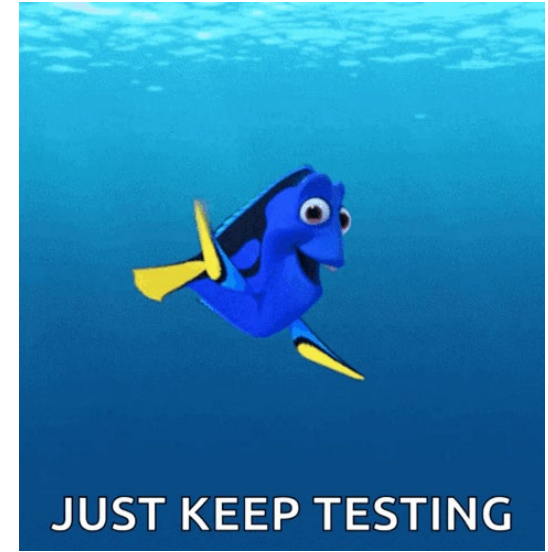



# PrEP Meds

Oral options

Daily or as needed (211 or PrEP on demand)

-Truvada-**Tenofovir disoproxil fumarate-emtricitabine** (TDF-FTC)

-Descovy-tenofovir alafenamide-emtricitabine (TAF-FTC)

Every 2 month injection

-Apretude-cabotegravir

Every 6 month injection-*coming soon*

-Lencapavir an HIV 1 capsid inhibitor



# PrEP Monitoring

HIV testing (HIV RNA)	Q3 months oral Q2 months inj*
STI testing	Q3 months oral At least Q4 months inj*
Lipids and Wt monitoring	Annual with Descovy
Renal Function	Annual or Q6 months >50yrs or CrCl <90ml/min
Hep C	Annual for MSM, <u>transwomen</u> who have sex with men, IVDU
Pregnancy Testing	every 3 months

# PrEP Barriers

Clinician knowledge and experience

Difficulty with frequency of appointments or lab testing





# Doxy PEP

Doxy PEP (given as 200mg doxycycline within 72 hours of condomless sex) can reduce the rate of chlamydia, syphilis, and possibly gonorrhea

Who to offer Doxy PEP to?

Men and transgender women who have sex with men

Men and transgender women with history of STI in past year

Men and transgender women with multiple partners



# Contact info

JesseDawn@gmail.com

773 241 0077

